

**Report of the  
Comptroller and Auditor General of India**

**Performance Audit of  
Construction activities in Central Armed Police Forces  
(CAPFs)**

**Union Government (Civil)  
Ministry of Home Affairs  
Report No. 35 of 2015  
(Performance Audit)**



## Contents

Index		Page No.
	<b>Preface</b>	iii
	<b>Executive Summary</b>	v-xii
<b>Chapter-I</b>	Introduction	1-8
<b>Chapter-II</b>	Planning and Budgeting	9-18
<b>Chapter-III</b>	Land Acquisition	19-30
<b>Chapter-IV</b>	Construction Activities -Issue Wise	31-66
<b>Chapter-V</b>	Comparative Study of Executing Agencies	67-74
<b>Chapter-VI</b>	Quality Assurance, Monitoring, Utilization and Maintenance of Assets	75-86
<b>Chapter-VII</b>	Financial Irregularities	87-96
<b>Chapter-VIII</b>	Construction Activities-Force Wise	97-106
<b>Chapter-IX</b>	Conclusion	107-110
	<b>Annexes</b>	113-267
	<b>Glossary</b>	268-271

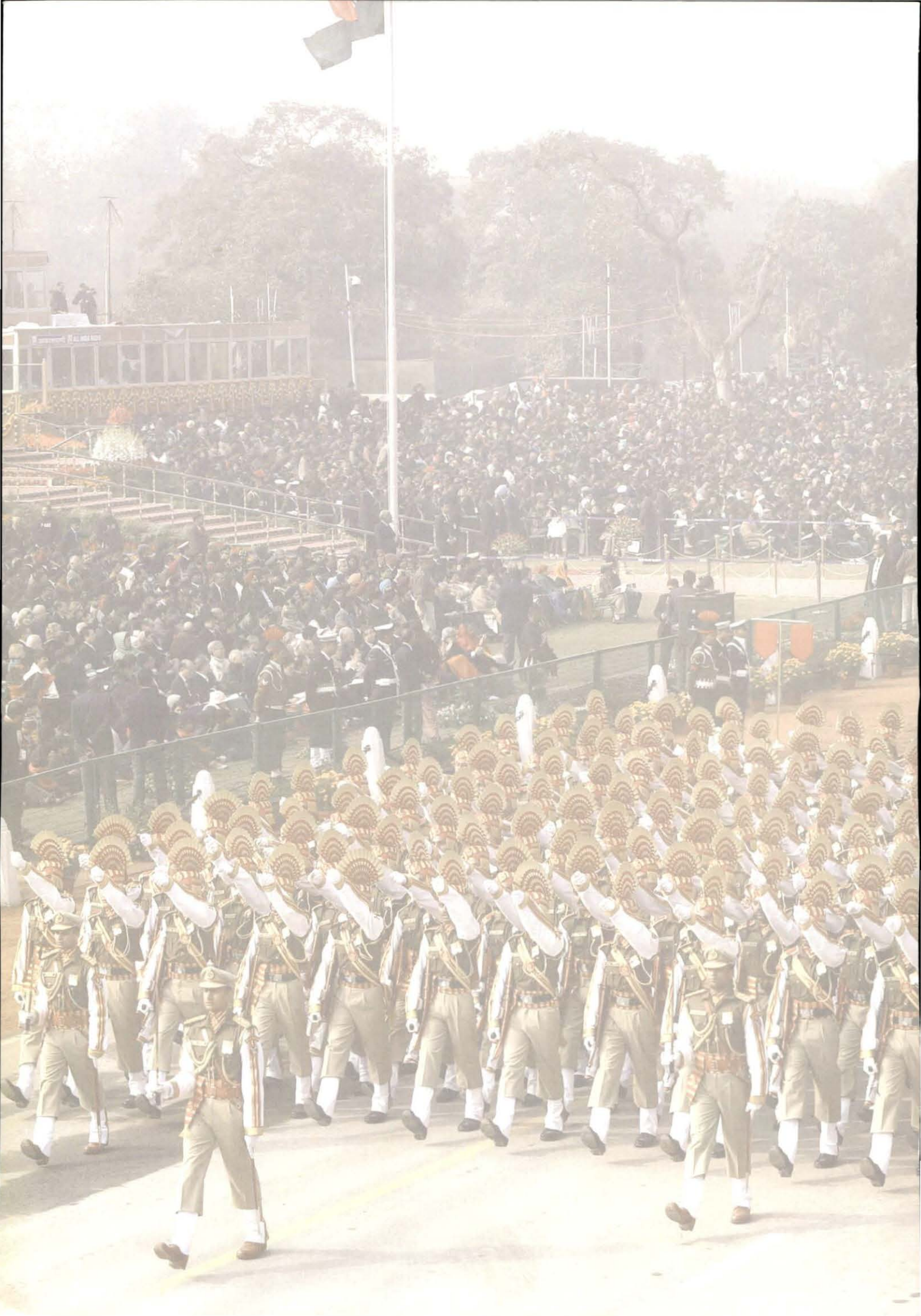

## Preface

The provision of proper office and housing facilities to Central Armed Police Forces (CAPFs) personnel has an important bearing on the morale of the force as they work for long hours in trying working conditions. Despite the priority accorded to creation of infrastructure for offices and residential accommodation for CAPFs by the central government through successive five year plans, the reality on the ground is disconcerting. Ministry of Home Affairs (MHA) while sanctioning the raising of units did not link adequate sanctions for the construction of office and residential buildings, which resulted in shortage of office and dwelling units for CAPFs. The conceptual framework for construction planning and activities was also modified successively by the MHA, but results were not encouraging, which was evident from prevailing low housing satisfaction level in CAPFs.

This all India performance audit assesses the status of construction activities in CAPFs and attempts to analyse the reasons as to why government lagged on this crucial welfare indicator. The core issues like delay in acquisition of land by CAPFs from state governments, lack of transparency in the selection of executing agencies, cost overrun and time overrun in construction projects, lack of coordination between executing agencies and CAPFs and poor monitoring of the construction projects by the executing agencies and CAPFs remained unresolved. If the government has to succeed in providing housing facilities to CAPFs in time, these flaws need to be fixed.

We hope that this Report prepared for submission to the President under Article 151 of the Constitution of India will throw up certain pointers to the planners and administrators in the government involved in this task of utmost importance for jawans guarding our borders and providing us internal security against terrorism and naxalism.

The audit has been conducted in conformity with the auditing standards issued by the Comptroller and Auditor General of India.

## Executive Summary

### Why did we select this subject for Audit?

The Ministry of Home Affairs (MHA) has a wide spectrum of responsibilities, the primary being internal security of the country, which involves the management of the Central Armed Police Forces (CAPFs). The seven armed police forces of Union of India are under the authoritative control of MHA. CAPFs play an important role in safeguarding the borders and maintaining internal security of the country. The shortcomings in providing proper office buildings and working environment hamper the working of these forces. The provision of housing facilities to CAPF personnel has an important bearing on the morale of the force as they work for long hours in far flung areas and under extreme weather conditions.

Past experience of our audit of CAPFs, including their Headquarters and field offices, revealed that delays in acquisition of land and completion of construction activities resulted not only in cost and time overruns but also deprived the recipients from getting timely benefits of construction activities. In this background, we decided to conduct this performance audit. Apart from auditing the role of MHA, CAPFs and executing agencies with regard to overall supervision of construction activities, we also focused on the causes for delay in the projects which led to cost and time overruns.

The period of coverage of this performance audit was from 2008-09 to 2013-14. Against an allocation of ₹ 12483.7 crore during 2008-09 to 2013-14, an amount of ₹ 12043.90 crore was incurred under major works including land acquisition cases by CAPFs.

### What were our audit objectives?

The performance audit was undertaken to assess whether:

- Adequate land as per the prescribed norms was acquired on time in a cost effective manner and made available for construction.
- Concerned agencies observed financial propriety during construction activity.
- Construction activities were carried out as per relevant government rules and regulations within the prescribed time frame and cost.
- Intended purpose behind the land acquisition and construction carried out was achieved effectively.
- MHA and CAPFs along with the executing agencies followed a strong monitoring mechanism to ensure the effective utilization of the available resources.

## What did our performance audit reveal?

Chapter-I provides background information on CAPFs and our audit approach and methodology. Chapter-II provides planning and budgeting requirement for office and residential buildings for CAPFs. Chapter-III and IV provides audit findings with respect to land acquisition cases and construction activities-Issue-wise respectively. Chapter-V deals with comparative analysis of executing agencies with respect to issues involved in planning and execution of works. Chapter-VI provides audit findings on the issues relating to quality assurance, monitoring aspects, utilisation and maintenance of assets created. Chapter-VII focuses on the financial irregularities committed by the executing agencies and CAPFs during execution of works. Chapter-VIII contains a comparative analysis of construction activities-Force-wise. Chapter-IX formulates a conclusion based on the audit findings of previous chapters. The important findings of the performance audit are given below:

### 1. Planning for construction activities

- MHA while sanctioning the raising of units did not link adequate sanctions for the construction of office and residential buildings.

**(Para 2.2.1)**

- MHA and CAPFs were not able to meet the requirement of office buildings as well as residential accommodation for CAPFs personnel. Against the authorised requirement of 2.99 lakh dwelling units, only 1.54 lakh dwelling units were available for CAPFs personnel and against the requirement of 5113 office buildings, only 2041 were available.

**(Para 2.2.1 & 2.2.2)**

- The satisfaction level in providing residential accommodation in CAPFs was low, ranging between 2.96 *per cent* to 22.48 *per cent* as on March 2014 against the targeted 25 *per cent* satisfaction level.

**(Para 2.2.2.1)**

- Public Work Organisations (PWOs) were selected by CAPFs purely on nomination basis. There was neither competitive environment nor transparency in the criteria of selection of PWOs in CAPFs for getting a better deal not just in terms of money, but also other deliverables such as adherence to time and quality and post handing over maintenance issues.

**(Para 2.5)**

### 2. Land Acquisition Process

- In 56 cases out of 132 selected land acquisition cases worth ₹ 236.05 crore, there was significant delay beyond prescribed time limit ranging between 5 months and 9.7 years in acquiring land from date of approval of Key Location Plan till taking over of possession of the land. Further, in 31 cases (23 *per cent*) of selected land acquisition

cases, CAPFs could not acquire the land within the prescribed time limit in spite of depositing the cost with the concerned state government.

(Para 3.1)

- In 23 cases, land was acquired in excess of authorisation, due to which an additional expenditure of ₹ 29.21 crore was incurred.

(Para 3.1)

- In five land acquisition cases in Kerala on lease basis, no clause was included in the lease deed for its extension after the expiry, which was in contravention of the guidelines issued by MHA. The conditions in the Lease Agreements were detrimental to the interest of the Force.

(Para 3.2.2)

- In 18 cases of land acquisition, sale deed/mutation was not executed by CAPFs which was in contravention of MHA guidelines.

(Para 3.2.4)

### 3. Construction Activities- Issue wise

- Preparation of incorrect preliminary estimates (PEs) by executing agencies resulted in inflated PEs by ₹ 14.22 crore.

(Para 4.1.4)

- There were no norms/time limits fixed either by MHA or by the PWOs for finalisation of PEs. This had a cascading effect on the subsequent milestones, pushing the project backwards by several months.

(Para 4.1.6)

- 6 works amounting to ₹ 206.62 crore were split up into 2 to 8 works by DsG of respective CAPFs/MHA in order to avoid the approval of higher authorities in contravention of Rule 130 of GFR.

(Para 4.2.1)

- There was no norm/time limit fixed by CAPFs/MHA for according sanction of administrative approval and expenditure sanction (AA/ES). In 197 works, MHA/CAPFs took more than five months (average time taken) in according AA & ES.

(Para 4.2.2)

- In 240 works of ₹ 1161.10 crore, the delay in tendering was up to 90 months from the date of sanction.

(Para 4.3.1)



- There were deviations in items beyond the permissible limit ranging from -100 per cent to +10469 per cent which indicated that quantities of items of work mentioned in the detailed estimates were not realistic and based on field survey and site conditions. Total amount of such items was ₹ 82.88crore.

(Para 4.5.2)

- Extra items worth ₹ 30.16 crore were executed by the executing agencies in 305 works. In 132 works, substituted items (ranging from 1 to 24 items) for ₹ 10.80 crore, were executed.

(Para 4.5.3 & 4.5.4)

- In 129 completed works, there was cost overrun of ₹ 63.02 crore. Besides, works which were in progress and incomplete, there was cost overrun of ₹ 85.03 crore up to December 2014. Thus, there was total cost overrun of ₹ 148.05 crore.

(Para 4.5.5.1)

- There was a savings of ₹ 289.08 crore in 189 completed works due to wrong calculation of plinth area by the department, modification of drawing, revision of estimate, site conditions etc.

(Para 4.5.5.1)

#### 4. Executing Agencies- A comparative Analysis

- CPWD took more time as compared to PWOs in tendering the works. Delay in award of work resulted in delay in their completion which ultimately resulted in cost overruns.

(Para 5.2)

- All executing agencies i.e. CPWD, PWOs and CAPFs having own engineering wing did not take approvals from the local authorities before issue of NIT in almost all works.

(Para 5.3)

- The works of CPWD had more deviations followed by departmental works and works executed by PWOs. It is indicative of the fact that quantities of items of work mentioned in the detailed estimates were not realistic and based on detailed field survey and as per the site conditions.

(Para 5.4)

- Out of 710 works checked, 405 works were delayed by 1 to 66 months. All agencies were almost equally placed when it came to delay in work completion. Delay in completion of work resulted in cost overrun due to rising cost index and caused avoidable financial burden.

(Para 5.5)

- There were large savings in the completed works executed by all the executing agencies. Huge savings were noticed in CPWD in 129 works worth ₹ 172.85 crore and in NBCC in 13 works ₹ 71.71 crore. This indicated poor financial control in budgeting and expenditure sanctions.

(Para 5.7)

## 5. Quality Assurance, Monitoring, Utilisation & Maintenance of Assets

- There was no practice of inspection by quality assurance wing of the CPWD. Further, PWOs viz. NBCC, NPCCL, EPIL HPL etc. did not have any quality assurance wings. In the absence of this, the assurance given by PWO about the quality of building was questionable.

(Para 6.1.1)

- The quality testing lapses viz. non-testing of material and water, testing of brand other than that was actually used, utilization of unapproved brand etc. were noticed in the works executed by CPWD/PWOs. Further, poor quality works viz. cracks on the walls in the quarters, peeling of plasters from walls, cracks in the roads, seepage in the residential quarters etc. were noticed during site visit/physical verification by audit.

(Para 6.1.2)

- Provision for third party inspection was not made in the MoU between CPWD/PWOs and CAPFs in 98 *per cent* works of CPWD and 100 *per cent* works of PWOs (except NBCC with 84 *per cent* works) and departmental works of CAPFs.

(Para 6.1.5)

- CPWD had a web based project monitoring system but data was neither being provided by CPWD to CAPFs nor did CAPFs ask for these.

(Para 6.2.1.6)

- Various residential and office buildings could not be handed over and put to use in many cases due to deficiencies like no provision of power supply, delay in energisation, etc. Further, buildings constructed for specific purposes were not utilised for intended purposes in many cases.

(Para 6.3.1&amp;6.3.2)

- The works executed by PWOs for CAPFs were not being maintained by PWOs as no provisions for maintenance of building were incorporated in their MoUs. CPWD was not ready to maintain these buildings on the plea that these buildings were not constructed by them. PWO who constructed it was demanding exorbitant charges for maintenance i.e. up to 20 *per cent* of the estimated cost of construction as agency charges.

(Para 6.4)

## 6. Financial Irregularities

- In 20 selected works, mobilisation advances amounting to ₹ 87.64 crore were given by the CAPFs to the executing agencies, but no separate project account for mobilization advance was maintained by the executing agencies.

(Para 7.1)

- Although there were delays up to 56 months in completion of works, no compensation/Liquidated Damage (LD) charges amounting to ₹ 19.86 crore were levied on the contractors.

(Para 7.2)

- Excess payment of ₹ 6.42 crore over the contractual stipulation was made to the contractors/PWOs. The excess payments made were mainly due to wrong calculation of price index, escalation of labour rates, cement and steel rates etc.

(Para 7.3)

- CPWD/PWOs failed to recover statutory recoveries viz. Works Contract Tax, Labour Cess, Income Tax deducted at Source (TDS), Value Added Tax (VAT) and Royalty amounting to ₹ 4.26 crore from the contractors.

(Para 7.5)

## 7. Force-wise comparison in construction activities

- Assam Rifles (AR) did not award any work to CPWD and selected other PWOs (100 per cent) on nomination basis for execution of their works, while BSF (21 per cent) and CRPF (20 per cent) preferred PWOs, other forces preferred CPWD.

(Para 8.1)

- SSB in 45 per cent and CRPF in 44 per cent selected works delayed in giving administrative approval and expenditure sanction (AA&ES).

(Para 8.3)

- 57 per cent works of NSG and 47 per cent works of ITBP were awarded after 6 months by the executing agencies. Similarly, about 50 per cent of works could not be completed in time in all CAPFs. It indicated the lack of coordination with the executing agencies by the CAPFs and not pushing the timelines effectively.

(Para 8.5)

- Financial irregularities viz. non-recoveries of statutory recoveries, liquidated damages, non-adjustment of mobilisation advance and interest thereon from the executing agencies/contractors were more pronounced in CRPF followed by CISF and AR.

(Para 8.6)

## What do we recommend?

- *MHA/Government may consider revamping the system in vogue for selection of PWOs to infuse competition among PWOs and thereby reduce the cost of construction along with improving quality and performance.*
- *MHA may facilitate CAPFs in acquiring land on timely basis by resolving administrative issues with states, through putting in place a structured mechanism of regular meetings at appropriate levels.*
- *MHA may revisit the time frame of one year and seven days fixed for land acquisition by CAPFs, as this was not met in any of the cases scrutinised by audit. CAPFs need to ensure during survey that land was free from all encumbrances.*
- *CAPFs may fix time frame for furnishing PEs and according AA & ES. This will help in reducing the time overrun during subsequent stages.*
- *CAPFs may set standards for construction works done departmentally, as it was not better in comparison to other PWOs in terms of planning and execution of works.*
- *CAPFs should ensure that works are inspected by Quality Assurance Wing of the PWOs. Third party inspection clauses should be incorporated in MoU to boost quality assurance levels.*
- *CAPFs should make practical use of the monitoring mechanism already in existence to bring meaningful results.*
- *CAPFs should initiate construction activities only after their priority assessment so that the buildings are put to immediate use for intended purpose.*
- *CAPF may incorporate provision for maintenance of buildings in the MoU itself to take care of their maintenance. CAPFs with engineering wings may undertake this process internally.*



## CHAPTER – I

## Introduction

## 1.1 GENERAL INFORMATION ABOUT THE AUDITEE

The Ministry of Home Affairs (MHA) has a wide spectrum of responsibilities, the primary being internal security of the country, which involves the management of the Central Armed Police Forces (CAPFs)<sup>1</sup>. The seven armed police forces of Union of India are under the authoritative control of MHA. The overview of these CAPFs along with their roles is as detailed below:

Chart 1.1: Role of CAPFs

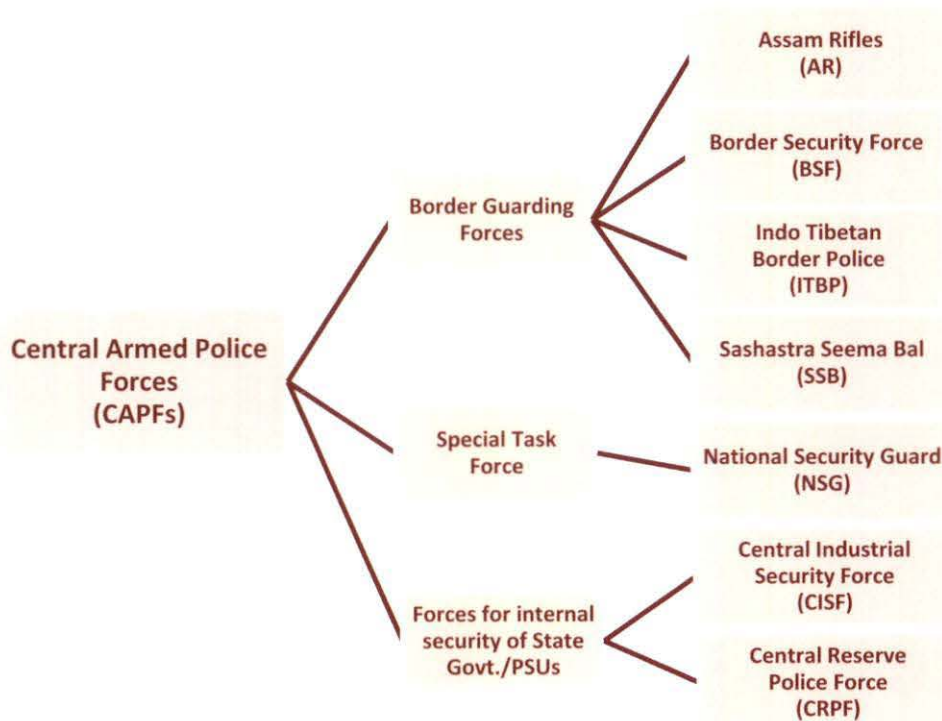

Out of these, AR, BSF, ITBP and SSB<sup>2</sup> are the '*Border Guarding Forces*' while CRPF assists the State Governments/UT Administrations in matters related to maintenance of public order. CISF provides security and protection to vital installations, Public Sector Undertakings (PSUs), airports, industrial units and important national institutions. NSG is

<sup>1</sup> Since March 2011, while all other forces are re-designated as Central Armed Police Forces (CAPF), Assam Rifles remains a Central Para Military Force (CPMF). However, for the purpose of this performance audit, CAPFs include Assam Rifles also.

<sup>2</sup> Abbreviations like AR for Assam Rifles are used throughout this document.

a specialized force for counter terrorism and anti-hijacking operations and is also entrusted with the task of VIP security.

## 1.2 ORGANOGRAM OF FORCES

Chart-1.2: Organizational Chart of CAPFs

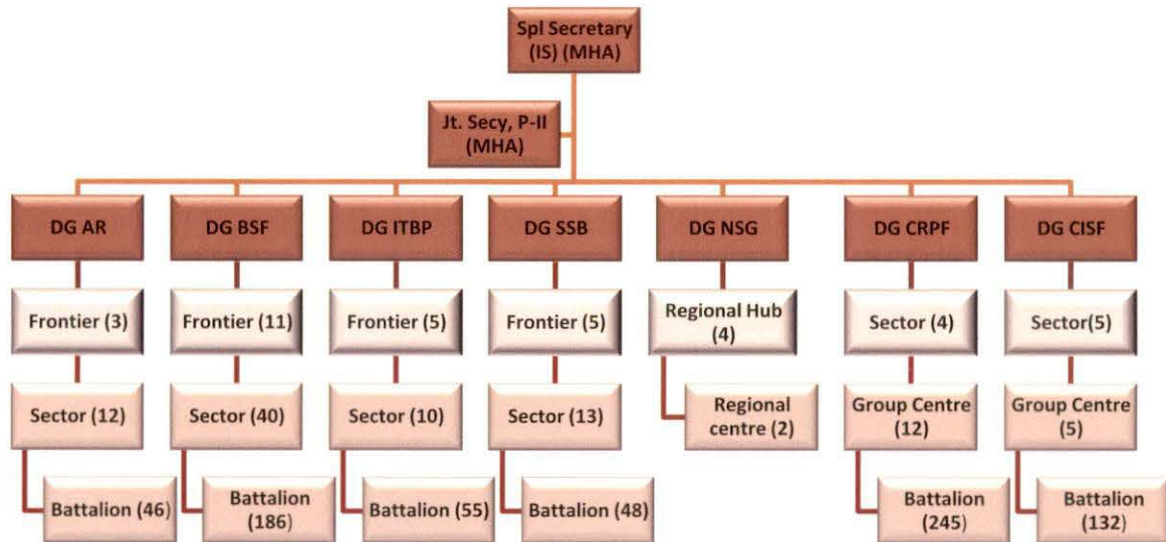

MHA is headed by Home Secretary who is assisted by Special Secretary (Internal Security). The Police II division of MHA under the SS(IS) headed by a Joint Secretary is responsible for processing the cases in respect of construction works of all the CAPFs. Each CAPF is headed by a Director General with HQrs. in Delhi except Assam Rifles which has its HQrs. in Shillong, Meghalaya. The sanctioned strength along with number of battalions of these CAPFs is depicted below:

Chart-1.3: Sanctioned Strength of CAPFs

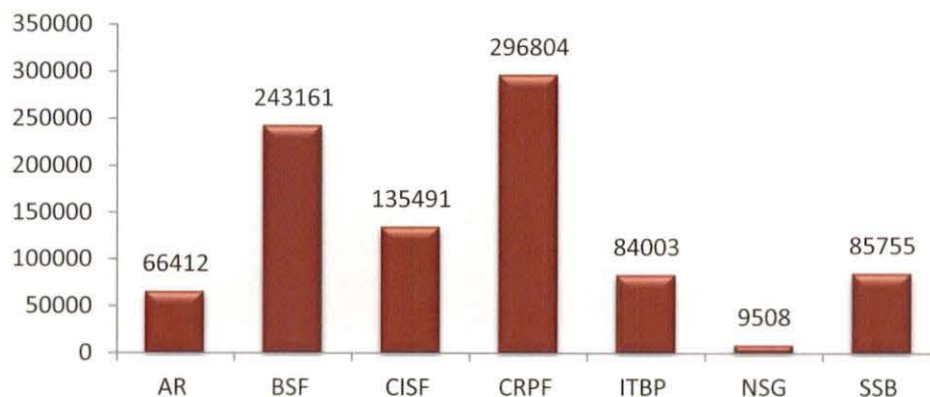

CAPFs are spread across the country, many of which are in remote/border areas. To function effectively, these forces require office complexes, training centres, residential buildings (including barracks) and Border Out Posts (BOPs) for guarding the borders.

For construction activities, CAPFs acquire land through State Governments and carry out their activities through government executing agencies like the Central Public Works Department (CPWD) and other Public Works Organizations (PWOs) such as National Building Construction Corporation (NBCC), Engineering Projects India Limited (EPIL), National Projects Construction Corporation Limited (NPCCL), Hindustan Prefab Limited (HPL) etc. CAPFs, viz. BSF, SSB, AR, ITBP and NSG have their own engineering wings also execute works up to an estimated cost of ₹ 60 lakh besides repair and renovation works.

### 1.3 BUDGETING BY MINISTRY

For acquisition of land and construction activities, MHA allocates budget under Capital (Major Works) to these CAPFs. In Major Works, budget is allocated under three sub heads viz., Office Buildings (OB), Residential Buildings (RB) and Border Out Posts (BOPs). Force-wise budget and expenditure under major works during 2008-09 to 2013-14 is placed at **Annex-1.1**. Total expenditure under major works including land acquisition cases by CAPFs for the period 2008-09 to 2013-14 was ₹ 12043.90 crore as detailed below:

**Chart 1.4: Expenditure on construction activities including land acquisition during 2008-09 to 2013-14 by CAPFs (₹ in crore)**



### 1.4 RATIONALE FOR SELECTION OF THIS TOPIC

During audit of MHA, it was noticed that a large portion of the plan expenditure of MHA was earmarked for the construction activities of the CAPFs. Past experience of our audit of CAPFs, including their HQrs. and field offices, revealed that delays in acquisition of land and completion of construction activities resulted not only in cost and time overruns but also deprived the recipients from getting timely benefits of construction activities. Since no performance audit on construction activities in CAPFs had been undertaken so far, it was decided to take up this issue. As this report focuses on important issues



relating to land acquisition, construction activities by PWOs, maintenance and utilisation of assets created, it would be of value to MHA, CAPFs as well as the executing agencies.

## 1.5 AUDIT OBJECTIVES

The performance audit was conducted with a view to examine economy, efficiency and effectiveness in construction activities in CAPFs. Specific audit objectives were the following:

1. Whether adequate land as per the prescribed norms was acquired on time in a cost effective manner and made available for construction.
2. Whether the concerned agencies observed financial propriety during construction activity.
3. Whether construction activities were carried out as per relevant government rules and regulations within the prescribed time frame and cost.
4. Whether the intended purpose behind the land acquisition and construction carried out was achieved effectively.
5. Whether the MHA and CAPFs along with the executing agencies followed a strong monitoring mechanism to ensure the effective utilization of the available resources.

## 1.6 AUDIT SCOPE AND COVERAGE

The performance audit was limited to major works above ₹ 10 lakh undertaken by CAPFs themselves or through various PWOs. Under major works, those executed through PWOs as well as the Engineering wings of the CAPFs were selected through random sampling. The main activities and agencies audited are depicted below:

Chart 1.5: Scope of audit

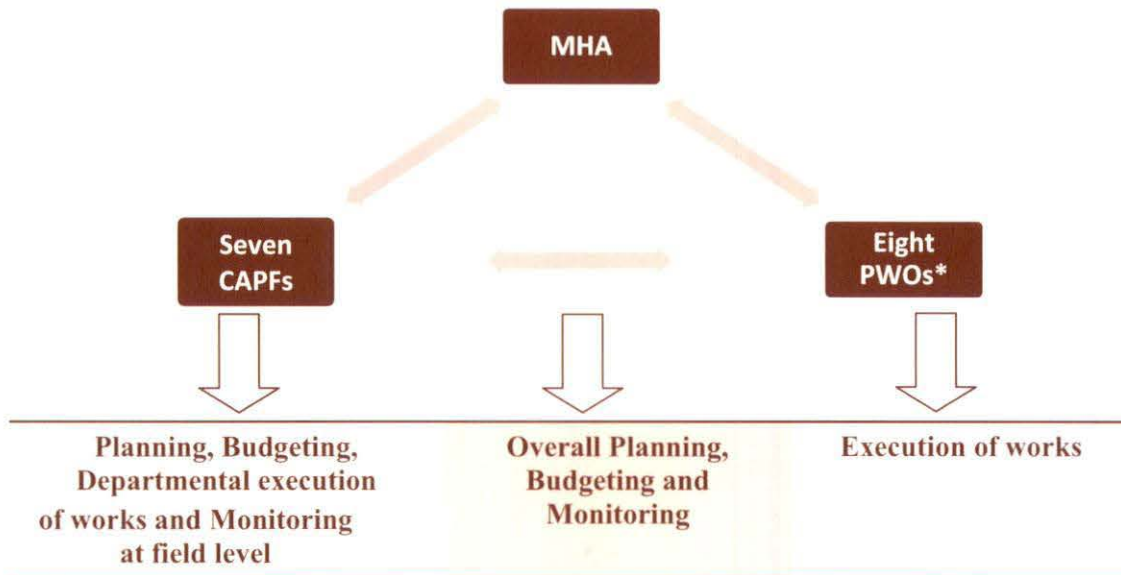

**Eight PWOs\*:** National Building Construction Corporation (NBCC), Engineering Projects India Limited (EPIL), National Projects Construction Corporation Limited (NPCCL), Hindustan Prefab Limited (HPL), Delhi Metro Rail Corporation (DMRC), Jammu and Kashmir Project Construction Corporation (JKPCC), Electricity Board Manipur (ECB), Uttar Pradesh Jal Nigam (UPJN)

The scope of audit covered the period from 2008-09 to 2013-14; but land acquisition cases and construction works sanctioned prior to audit period which were ongoing during the audit period were also covered. Field audit was conducted through the audit offices of CAG located across the country, covering construction activities in all the states.

The following works are excluded from the scope of this performance audit:

- ❖ Major works below ₹ 10 lakh and minor works undertaken by the CAPFs.
- ❖ Projects of Border Out Posts (BOPs) funded through the Border Management Division of MHA.

## 1.7 SOURCES OF AUDIT CRITERIA

The construction activities undertaken by CAPFs, performance of the Ministry and executing agencies were evaluated on the basis of the following criteria:

- i) CPWD Manual
- ii) CPWA Code
- iii) General Financial Rules
- iv) Manual of policies and procedures for Works Contract
- v) Guidelines issued by Central Vigilance Commission for Works Contract
- vi) Guidelines issued by MHA to CAPFs in respect of land acquisition and construction activities
- vii) Manuals and policies of concerned Public Works Organisations (other than CPWD)
- viii) Land Acquisition Act 1894 (Revised with effect from 1 January 2014)
- ix) Other relevant government rules and regulations

## 1.8 AUDIT SAMPLE

Sample for land acquisition cases and works was selected force wise through Interactive Data Extraction and Analysis (IDEA) software in proportion to number of cases pertaining to a particular force in the audit universe. After calculation of sample size, data for cases where sanctions were granted in last 6 years were arranged. Multi-layer sampling was adopted for major works relating to construction activities. The following criteria were adopted for scientific random sampling:

**Table-1.1: Criteria for sampling of land/works more than ₹ 60 lakh**

Details of works	Percentage of selection for audit	Total number
Land acquisition cases	20	132
Works with estimated cost above ₹ 5.00 crore	33	418
Works with estimated cost from ₹ 60 lakh to ₹ 5 crore	25	

Besides this, the selection of the sample in the following categories has been done by the respective DsG/PDs Central Audit offices as per the framework provided in the succeeding para :

**Table 1.2: Criteria for sampling of ongoing works/land cases and works less than ₹ 60 lakh**

Details of works	Percentage of selection for audit
Works with estimated cost less than ₹ 60 lakh	20 per cent (subject to maximum 5 works from each force)
Ongoing works sanctioned prior to 1 April 2008	100 per cent (subject to maximum 20)
Pending land acquisition cases sanctioned prior to 1 April 2008	100 per cent (subject to maximum 20)

The resultant total samples selected in land cases and construction works during the period 2008-09 to 2013-14 for this performance audit is as follows:

**Table-1.3: Details of force wise selection of work and land cases**

		AR	BSF	CISF	CRPF	ITBP	NSG	SSB	TOTAL
Land Cases	<b>Total</b>	11	156	12	62	33	7	333	<b>614</b>
	<b>Selected</b>	5	35	6	13	8	3	62	<b>132</b>
Works above ₹60 lakh	<b>Total</b>	448	470	86	164	240	32	214	<b>1654</b>
	<b>Selected</b>	115	105	21	51	65	08	53	<b>418</b>
Works ₹10 to ₹ 60 lakh	<b>Total</b>	896	1242	154	277	105	42	109	<b>2825</b>
	<b>Selected</b>	05	46	29	55	31	05	19	<b>190</b>
Ongoing	<b>Total</b>	27	4	12	72	10	1	3	<b>129</b>
	<b>Selected</b>	12	04	11	65	06	01	03	<b>102</b>
Total land cases	<b>Selected</b>	5	35	6	13	8	3	62	<b>132</b>
Total works	<b>Selected</b>	132	155	57	166	102	14	75	<b>710</b>

List of above 132 land acquisition cases and 710 works are placed at **Annex-1.2** and **Annex-1.3** respectively.

## 1.9 AUDIT METHODOLOGY

The audit methodology consisted of an entry conference, scrutiny of records/documents of MHA, CAPFs and different executing agencies, interviews with concerned officials and physical inspection of sites, including collection of photographic evidence.

Entry conference was held on 12 June 2014 by Director General of Audit (Central Expenditure) with the Joint Secretary of MHA along with representatives of all the CAPFs and executing agencies to explain the audit objectives and approach. Field audit was conducted between June and December 2014. All the field audit offices also held entry conferences in their respective audit jurisdictions with the auditee organisations before taking up the audit.

Draft agency-specific audit observations were communicated to the field units of CAPFs and executing agencies in January-March 2015 for their responses. Exit Conferences were held at central offices of CAPFs and executing agencies at appropriate levels. An exit conference co-chaired by Special Secretary (Internal Security) and Director General of Audit (Central Expenditure) was held in MHA along with representatives from MHA, CAPFs and PWOs on 29 May 2015. The responses of these agencies at various levels have been examined and suitably incorporated. Response from MHA in the exit conference and their replies has also been taken into account while finalising this Report.

## 1.10 SCOPE LIMITATION

Despite our best efforts and repeated reminders, certain records and information as detailed in **Annex-1.4** were not provided by the Executing Agencies.

## 1.11 ACKNOWLEDGEMENT

The Indian Audit and Accounts Department acknowledges the cooperation and assistance extended by MHA and all the seven CAPFs. We also acknowledge the cooperation and assistance extended by executing agencies viz. CPWD and other PWOs in providing necessary information and record to audit.

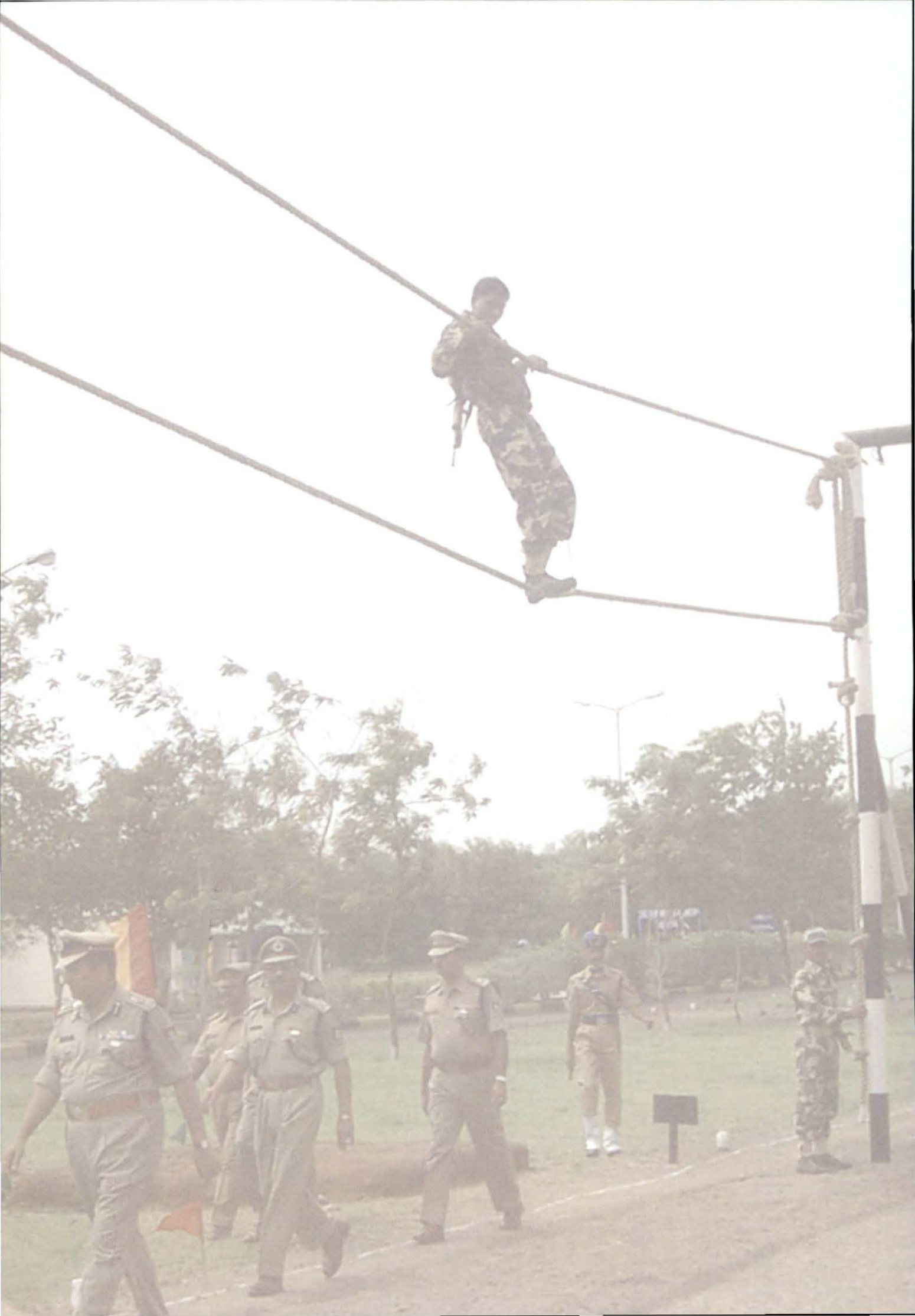

## CHAPTER – II

# Planning and Budgeting

## 2.1 PLANNING FOR CONSTRUCTION ACTIVITIES

Planning for construction in CAPFs consists of following two streams of work :

- (i) Construction for new battalions/sectors raised as part of strategic decisions of MHA.
- (ii) Regular construction activities which may be new constructions or major repairs.

MHA decides to raise battalions of the border guarding forces and NSG after analysis of security requirements and inputs received from various security and intelligence agencies. For other CAPFs except CISF, MHA from time to time reviews the strength and accordingly increases the number of units like battalion, sector, frontier offices etc. as per their administrative requirements. Units in CISF are raised according to the security requirements of establishments like PSUs etc., for which MHA decides to deploy CISF units. The construction of office buildings and residential buildings is required as and when battalions and other offices are sanctioned by MHA. During the period 2008-09 to 2013-14, MHA sanctioned the establishment of the following units in CAPFs:

**Table-2.1: Details of sanctioned and raising of units in CAPFs during audit period**

Name of Force	IG office		DIG office		Battalions	
	Sanctioned	Raised	Sanctioned	Raised	Sanctioned	Raised
AR	1	1	3	3	5	5
BSF	3	3	7	7	29	29
CISF	0	0	0	0	4	0
CRPF	6	6	4	4	31	31
ITBP	1	1	4	4	16	16
NSG	4 Hubs	4 Hubs	NA	NA	NA	NA
SSB	3	2	9	7	32	26
<b>TOTAL</b>	<b>14+(4 Hubs)</b>	<b>13+(4 Hubs)</b>	<b>27</b>	<b>25</b>	<b>117</b>	<b>107</b>

From the inputs described above, forces prepare a perspective five year construction plan. After the approval of Director General (DG) of each CAPF, these are forwarded to MHA. These plans are the blue print based on which budgetary requirement for each year is prepared by CAPFs. 12th five year plan activities were submitted by forces to MHA in 2011-12. Till 2010-11, MHA allocated the budget for construction activities to CAPFs both under Plan and Non Plan heads. However, from 2011-12, MHA started allocating the budget for construction activities to CAPFs under Plan head only. The status of 11<sup>th</sup> and 12<sup>th</sup> five year plan is as depicted below:

**Chart-2.1: Budget and Expenditure of construction works during 11<sup>th</sup> and 12<sup>th</sup> Five Year plan**

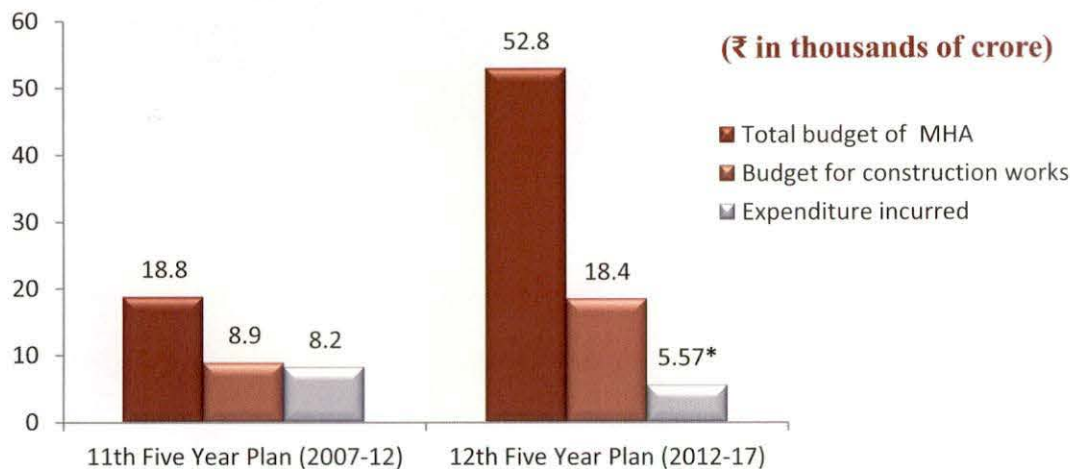

(\*12<sup>th</sup> Five year plan-Expenditure figure shown up to 2013-14)

Audit noticed that there was a laid down system for planned development of buildings and other allied infrastructures of CAPFs. All CAPFs prepared five year plans for construction activities and adhered to them during the audit period of 2008-09 to 2013-14.

## 2.2 REQUIREMENT AND AVAILABILITY OF OFFICE & RESIDENTIAL BUILDINGS

The need for offices and residential buildings is assessed by the Engineering Wing of CAPFs based on inputs from field or as decided by MHA for new units. This is based on the sanctioned strength and space requirement for offices and houses. Audit analyzed the data received from CAPFs and MHA as on 31 March 2014 on requirement and availability of office and residential buildings as explained in the succeeding paragraphs.

### 2.2.1 Requirement and availability of Office Buildings

**Chart-2.2: Position of office buildings in CAPFs**

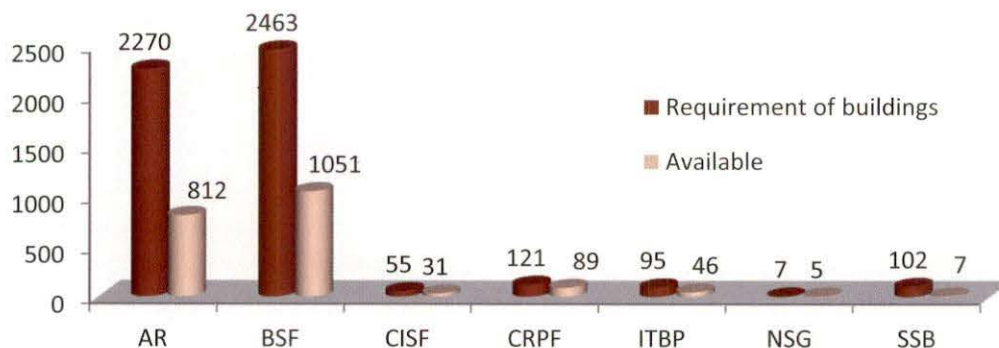

This data forms the basis for planning the construction activities in CAPFs, which translates into five year plans and annual budgetary requirements. It was noticed that against the requirement of 5113 office buildings, only 2041 were available. There was a large gap in requirement and availability of office buildings in CAPFs which is evident from the position stated above as on March 2014. Audit felt that MHA while sanctioning the raising of units and battalions did not link adequate sanctions for the construction of office and residential buildings. The deficiency, which was most pronounced in the case of SSB in providing proper office buildings and working environment may hamper the working of the forces.

## 2.2.2 Requirement and availability of Residential Buildings

The provision of housing facilities to CAPF personnel has an important bearing on the morale of the force as they work for long hours in far flung areas and stay in tents and barracks. The year-wise authorized and available dwelling units of CAPFs during the period 2008-09 to 2013-14 were as under:

**Chart-2.3: Year-wise authorized and available dwelling units for CAPFs (in lakh)**

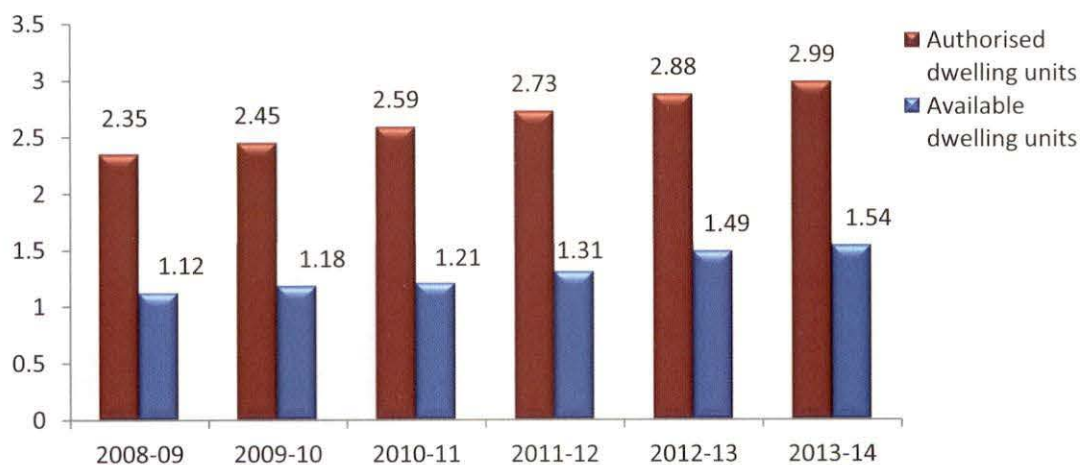

It was evident from above that authorized dwelling units of CAPFs increased from 2.35 lakh to 2.99 lakh during 2008-09 to 2013-14, but available dwelling units for CAPFs increased only from 1.12 lakh to 1.54 lakh during the above period. There was a short fall in dwelling units for CAPFs ranging between 1.23 lakh to 1.45 lakh showing no synchronization between authorization and availability of dwelling units for CAPFs.



The force-wise status of authorization and availability of residential accommodation during 2013-14 was as depicted below:

**Chart-2.4: Force-wise position of authorised & available dwelling units**

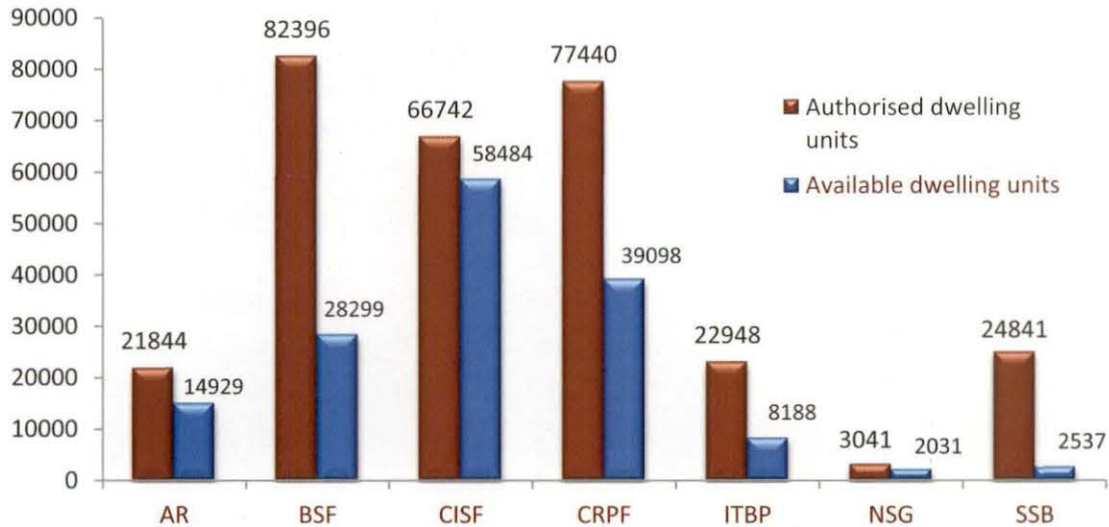

Force-wise position of authorized vis-à-vis available dwelling units for CAPFs personnel as on March 2014 reflects huge gap, especially for SSB, BSF and ITBP, being more than 50 per cent.

**Chart-2.5: Shortage of dwelling units in per cent**

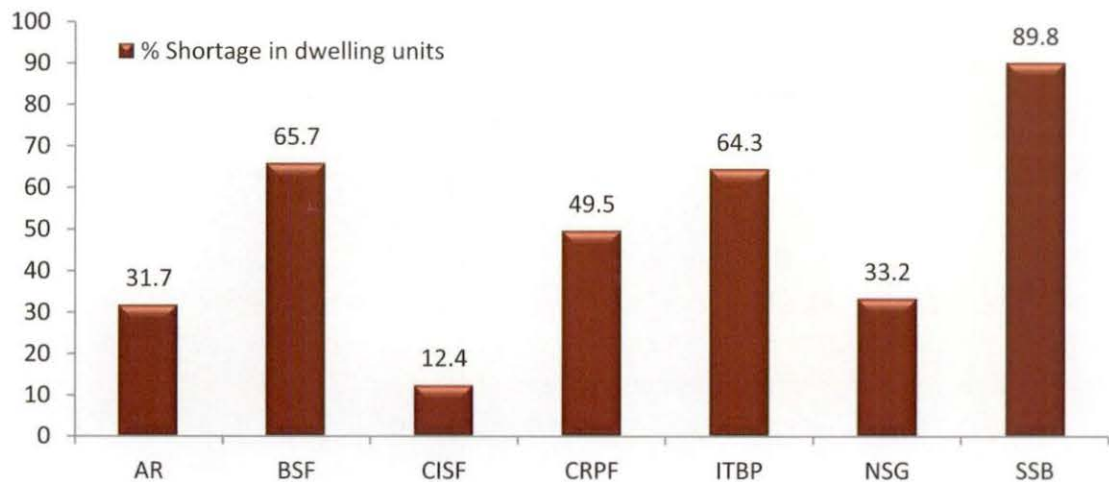

The minimum shortfall of 12.4 per cent was in case of CISF as accommodation for CISF units deployed in Public Sector Units (PSUs) was to be provided by the client Public Sector Undertakings (PSUs). The above position indicated that MHA was not able to provide even the authorized residential accommodation (i.e. sanctioned by the MHA) to CAPFs personnel.

**2.2.2.1 Housing satisfaction level in CAPFs**

The satisfaction level in respect of sanctioned strength and available dwelling units for CAPFs up to 2010-11 was 14 per cent. The Group of Ministers on Reforming the National Security System recommended enhancement of the satisfaction level from 14 percent to 25 percent for other ranks in CAPFs during 2010-11.

Audit examination of records of MHA revealed that the satisfaction level in CAPFs was worked out by MHA on the basis of sanctioned strength and availability of dwelling units in each force. The status of force-wise requirement as per sanctioned strength and availability of residential accommodation during 2013-14 was as follows:

**Chart-2.6: Force wise position of requirement and availability of dwelling units**

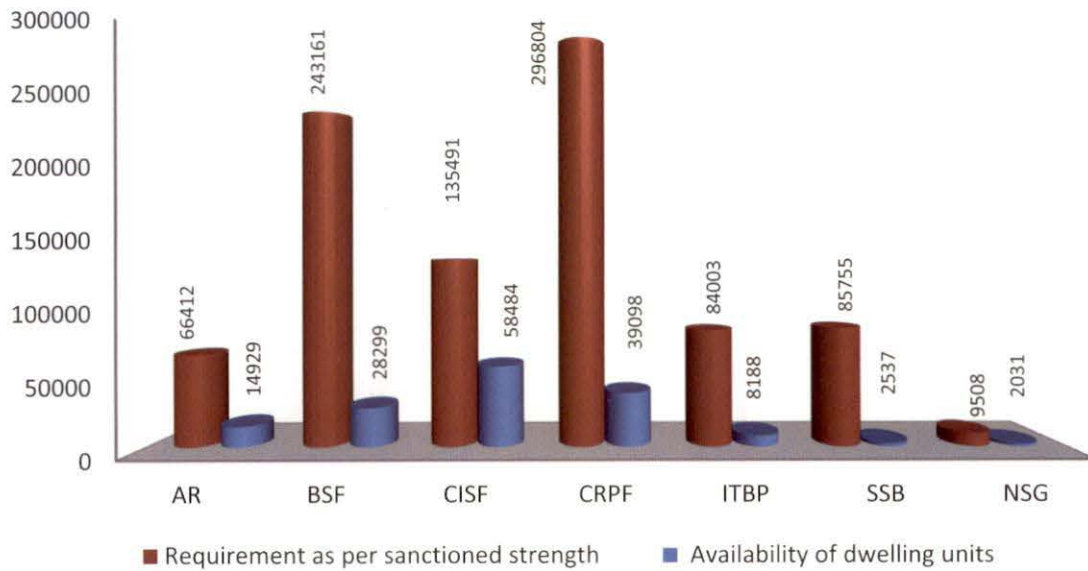

On the basis of requirement as per sanctioned strength and available dwelling units in each force, satisfaction level as on March 2014 was worked out and shown below:

**Chart-2.7: Satisfaction level of residential accommodation in CAPFs**

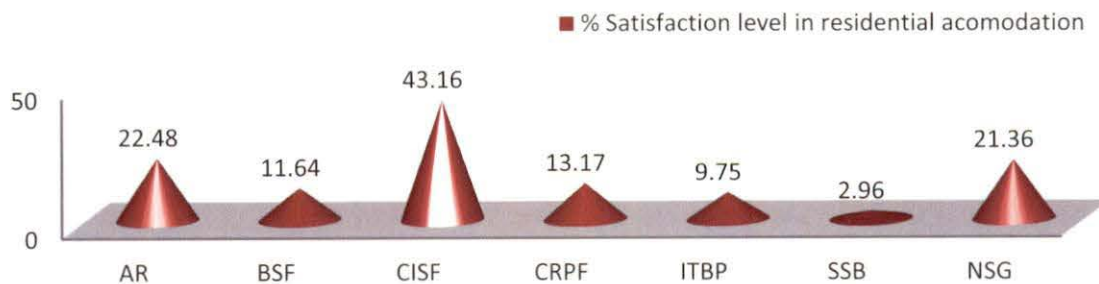

\* The above data pertains to forces as a whole without distinction between officers and other ranks.

Audit noticed that the satisfaction level in providing residential accommodation in CAPFs was low, ranging between 2.96 per cent and 22.48 per cent as on March 2014. The satisfaction level in AR and NSG was high, while in CISF it was the highest. This was due to the fact that accommodation for CISF units deployed in Public Sector Units (PSUs) was to be provided by them and PSUs were generally able to provide accommodation. It was noticed that for non-PSU units of CISF, satisfaction level was 13.61 per cent as for these units responsibility to provide accommodation rests with CISF and MHA. In remaining forces, the position of satisfaction level was low. The details were not available in MHA to verify the satisfaction level in other ranks as recommended by Group of Ministers as the data was maintained without any distinction between officers and other ranks.

Thus, it was evident that the available dwelling units vis-à-vis authorised dwelling units did not keep pace with the increase in sanctioned strength of CAPFs.

### 2.3 BUDGETING

MHA compiles the total requirement of all the forces and then submits it to the Ministry of Finance which allots the budget to MHA, which in turn distributes it among CAPFs according to availability. CAPFs thus prioritize the works as per availability of budget with them. The force wise budget and expenditure under major works during 2008-09 to 2013-14 is placed at **Annex-1.1**. The year wise details of budget and expenditure of major works during audit period are as follows:

**Chart-2.8: Details of Revised Budget and Expenditure for Major Works including land acquisition cases**

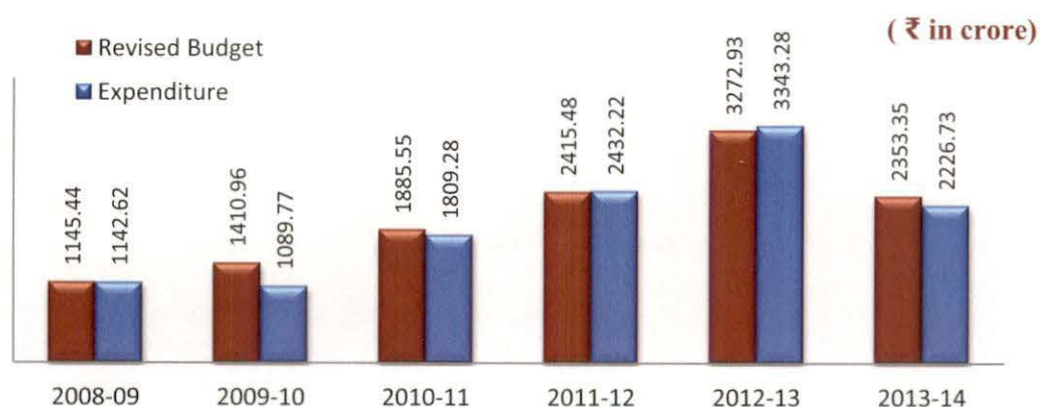

The above expenditure was incurred by CAPFs during 2008-09 to 2013-14 mainly for land acquisition and construction activities. The total expenditure on major works including land acquisition cases by CAPFs for the period 2008-09 to 2013-14 was ₹ 12043.90 crore. When there were budgetary constraints, forces allocated the available resources to most important tasks. Audit noticed that the difference between requirement

and allocated budget was the result of a general cut imposed by Ministry of Finance across the board.

## 2.4 APPROVAL PROCESS FOR CONSTRUCTION ACTIVITIES

The process of construction works for new establishments starts from approval of battalions/sector offices as detailed below:

**Chart-2.9: Details of approval process for construction activities**

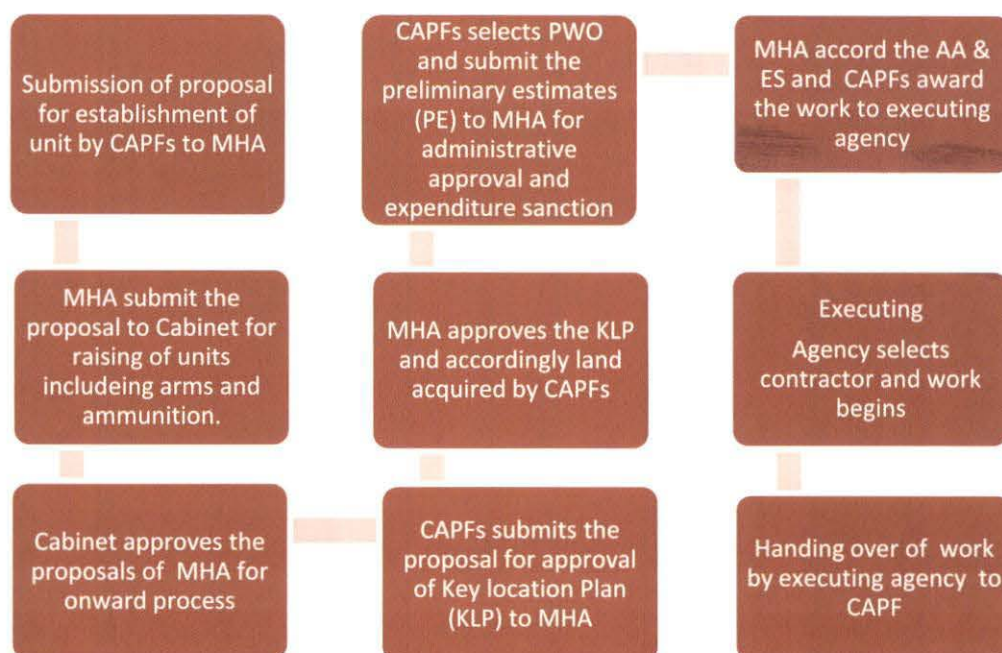

## 2.5 SELECTION OF EXECUTING AGENCY

After necessary approvals, the process of construction works starts with the selection of the executing agency. The executing agency prepares the preliminary estimates based on which administrative approval and expenditure sanction are issued by the competent authority. After receipt of administrative approval by CAPF, executing agencies award the work to eligible contractors through tendering process and get the work done from them.

Rule 126 (2) of GFR states that a Ministry or Department may at its discretion assign original works of any value to any Public Works Organisation, such as Central Public Works Department (CPWD), State Public Works Divisions or other Central Government Organisations authorized to carry out civil or electrical works such as the Military Engineering Service (MES), Border Roads Organisations (BRO), Public Sector Undertakings or any other Central / State Govt. organization / PSU which may be notified by the Ministry of Urban Development after evaluation of their financial strength and technical competence. Rule 126 (3) states that a Ministry or Department may also

execute works through a well reputed and technically competent organization, other than PWOs as defined in Rule 126(2), after consultation with Ministry of Urban Development.

Out of 710 construction works sampled for audit, executing agency-wise selection of works are depicted below:

**Chart-2.10: Executing Agency wise selected works**

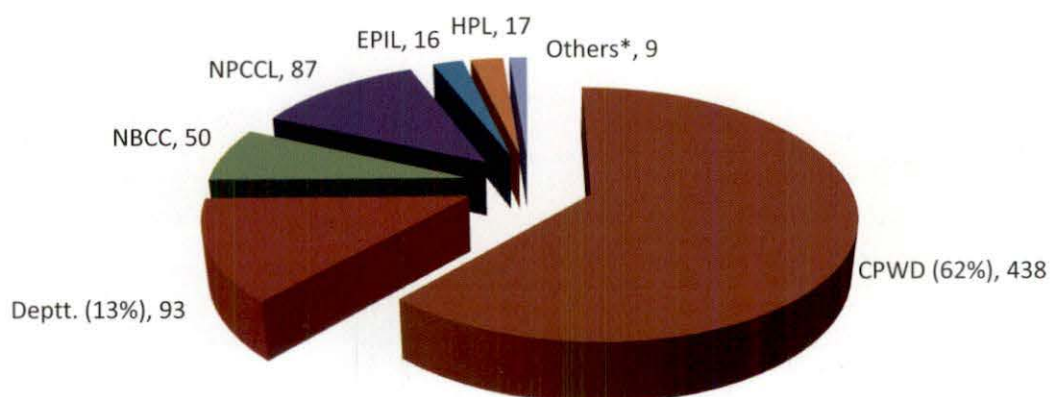

**Others\*:** DMRC-1, JKPCC-1, ECB-1, UPJN-6

Audit scrutiny of records revealed that CPWD was selected as the executing agency as a matter of routine, being a government agency. Other PWOs, when chosen, were selected on nomination basis. No reasons or selection criteria were found on record in respect of selection of these executing agencies except in case of Assam Rifles (AR) which awarded all their works to PWOs other than CPWD. While awarding the works to these PWOs, the main reason quoted by AR was, delay in completion of works by CPWD which resulted in cost escalation.

Audit view is that the present system of over-riding dependence on CPWD and usage of their schedule of rates even by non-CPWD executing agencies, as an immutable starting point, was not conducive to efficiency. Unless motivated by strategic concerns, there was no reason why a more competitive environment could not be created for getting best value for public money. The government should consider infusing some competition amongst PWOs through suitable administrative changes, instead of awarding work on a purely nomination basis.

MHA accepted (July 2015) the observation by stating that GFR 126(2) *inter-alia* provides that Ministry or Department may, at its discretion, assign works to any Public Works Organization, such as CPWD, State Public Works Divisions, other Central Government Organizations authorized to carry out civil or electrical works. It further stated that the Ministry is examining the matter of awarding the work to GFR qualified PWOs/PSUs to further streamline the process of their selection.

### 2.5.1 Expenditure by Executing Agency

CAPFs give authorization to CPWD after the administrative approval and expenditure sanction for the construction work. Authorisations are given as per requirement submitted by CPWD to the CAPFs. It was noticed that all CAPFs were not following a similar pattern in giving funds to CPWD. CAPFs except CRPF, while giving funds to CPWD did not enquire about work wise

requirements. In the absence of this, details of the expenditure incurred and saving, if any, on a particular work was not known to the CAPFs. However, CRPF adopted a different system which was much better than other forces.

#### GOOD PRACTICE

CRPF, before giving authorization to CPWD, checked the status of works and their work wise requirements for the following year. On the basis of work-wise requirements, CRPF allotted the funds and accordingly received work-wise expenditure statements from CPWD at the end of the year, leading to a better budgeting and fund management.

#### RECOMMENDATION:

MHA/Government may consider revamping the system in vogue for selection of PWOs to infuse competition among PWOs to reduce the cost of construction and improve quality and performance.

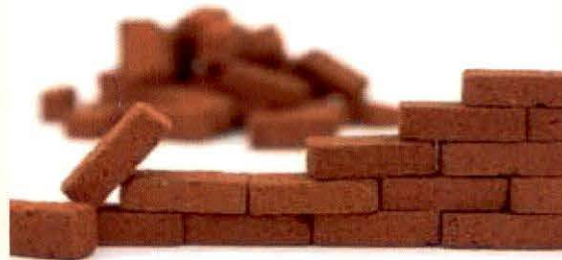

### 2.5.2 Overarching control and responsibility centers

MHA being the nodal Ministry is responsible for overall monitoring to ensure that the budget allotted was expended economically and efficiently in a timely manner for the purpose for which it was sanctioned. MHA through concerned CAPFs monitors the delayed works through monitoring meetings with CPWD and PWOs. It was found that execution of works was mainly taken to be the responsibility of executing agencies. CAPFs were not involved during the execution of the works. This was more pronounced in the works executed by CPWD. In respect of works executed through PWOs other than CPWD also, monitoring by CAPFs was minimal and perfunctory. The only monitoring was the checking of bills submitted by executing agency for calculation mistakes. Monitoring mechanism has been discussed in detail in **Chapter-VI**.

## 2.6 CONCLUSION

It was seen that the requirement of the forces, both for office and residential accommodation, was not addressed fully. Selection of executing agency for construction works was not based on any criteria and competition was lacking amongst the executing agencies. The present system of over-riding dependence on CPWD and usage of their schedule of rates even by non-CPWD executing agencies, as an immutable starting point, was not conducive to efficiency. The government should consider infusing some competition amongst PWOs through suitable administrative changes, instead of awarding work on a purely nomination basis. The near absence of supervision of works by the CAPFs did not reflect a healthy picture and the absence of engineering wing was not a valid excuse. The budgetary system, though in position, also needed improvement, especially in the area of release of payments.

## CHAPTER – III

## Land Acquisition

Land being a key resource in timely establishment of CAPF formations, an attempt was made in audit to ascertain the adequacy of land availability, constraints in land acquisition, time taken in acquisition and utilisation of land.

Whenever requirement of land arises for construction of a new unit, approval of Key Location Plan (KLP) of the unit is to be obtained from MHA. KLP is the location where a new field formation can be established and is a strategic decision. Thereafter, a site selection committee is constituted by CAPF which identifies and assesses the specific site. After the approval of MHA, the CAPF has to acquire land through state governments as per the provisions of Land Acquisition Act, 1894 (Revised with effect from 1 January 2014) and Right to Fair Compensation and Transparency in Land Acquisition, Rehabilitation and Resettlement Act- 2013 (which came into force from 1 January 2014). MHA in March 2009 reduced the time to be taken from their earlier level of 2 ¼ years to 1 year 7 days in order to get the land acquisition process completed in a time bound manner.

Guidelines regarding acquisition of land by CAPFs issued by MHA in March 2009 envisaged that:

- Approval of Key Location Plan (KLP) of the unit has to be obtained from MHA before land acquisition proceedings are initiated.
- Land should be acquired through the state government and not through direct negotiation with landowners.
- Land proposed for acquisition should be free from encroachment and there should be no dispute regarding ownership of land.
- No permanent construction should be undertaken unless the land has been acquired and a clear title has been obtained.
- The land documents viz. copy of gazette notification, stamped receipt, sale deed (for private land), and possession certificate of land should be obtained from the district collector or the concerned state government.
- Survey sketch of land showing Patta/Chithas with Dag No. /Plot No. of land duly amended in the name of the CAPFs and authenticated by land records/Revenue authorities should be obtained.
- Proper demarcation of land by erecting boundary pillars and fencing of land, where feasible, should be carried out.



- No High Tension (HT) power line should cross the proposed land and if HT line is unavoidable, then force should purchase extra land.
- Validity of the lease should be 99 years. If the initial lease period is less than 99 years, then, there must be clause for further extension in the lease deed. Further, provisions for claiming compensations for buildings and other assets created by the CAPF in the event of vacation of the land at any stage should also be included in the lease deed. The draft lease deed should be forwarded to Force Head Quarter for vetting/approval before execution.

### 3.1 DEVIATIONS IN LAND ACQUISITION

Audit scrutinised 132 cases of land acquisition involving 14,320 acres across CAPFs worth ₹ 415 crore. It was found that overall performance in land acquisition was not satisfactory. Land acquisition cases which showed aberrations are quantified in the table below and explained thereafter.

**Table 3.1: Details of delay and deviation in acquisition of land by CAPFs**

(₹ in crore)

Cases of Deviation	No. of cases	Money value
<b>Delay/Non acquisition of land (Annex-1.2)</b>		
Delay in acquisition	56	236.05
Non- acquisition of land	31	147.85
<b>Deviation in acquisition (Annex-3.4)</b>		
- Excess acquisition	23	134.58 (29.21)*
- Short acquisition	44	

\*Excess expenditure on excess acquisition of land

The time period prescribed by MHA for acquisition of land was reduced from 2 ¼ years to 1 year and 7 days so that the utilization of land could be started at the earliest. Audit noticed that in 87 cases (66 per cent) out of 132 selected land acquisition cases, there was considerable delay ranging between 5 months and 9.7 years in acquiring land from date of approval of KLP till taking over of possession of the land (**Annex-1.2, S. No. 1 to 87**).

Out of these, in 31 cases (23 per cent) of land acquisition of 877.57 acre with a sanctioned cost of ₹ 147.85 crore, CAPFs could not acquire the land even after depositing the cost to the concerned state government till December 2014. In 23 cases, the CAPFs acquired land in excess of authorisation, due to which an additional expenditure of ₹ 29.21 crore was incurred. The main reasons for non-acquisition of land were lack of proper coordination with state government and efforts by the CAPFs to pursue the case at the appropriate level. Further, other reasons for delays were non-submission of requisite documents to State Land Acquisition Officers (SLAO), defective survey, delay in taking decision for purchase of land and exceptional time taken in obtaining estimation from SLAO. In many cases, protracted correspondence between CAPF, state and MHA took

long time to materialise the land acquisition case. Force-wise delay and non-acquisition of land cases is shown below:

**Chart-3.1: Force-wise position of delay in land acquisition cases**

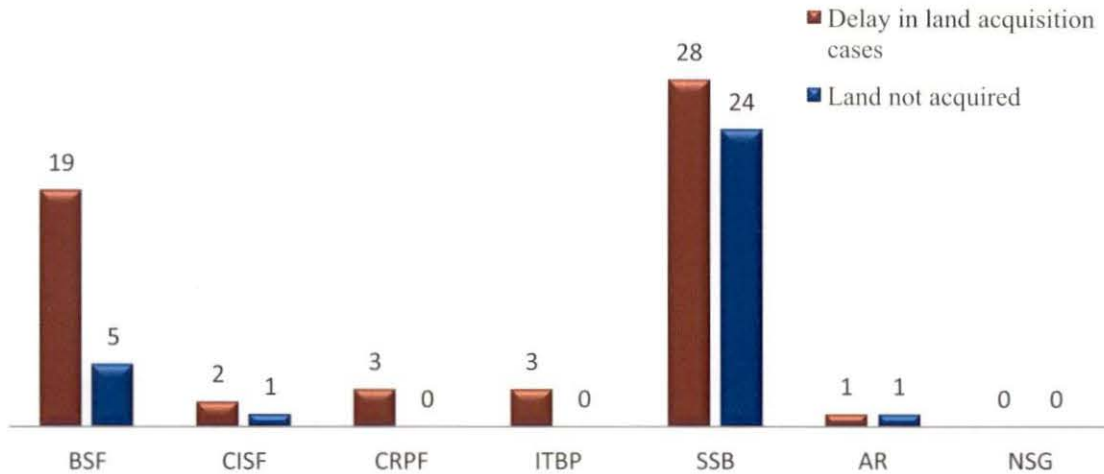

CAPFs admitted the delay and attributed the same to the delay on the part of State Governments.

Audit further analysed the state-wise delays in land acquisition, the position was shown in diagram below:

**Chart 3.2: State wise position of delay in land acquisition**

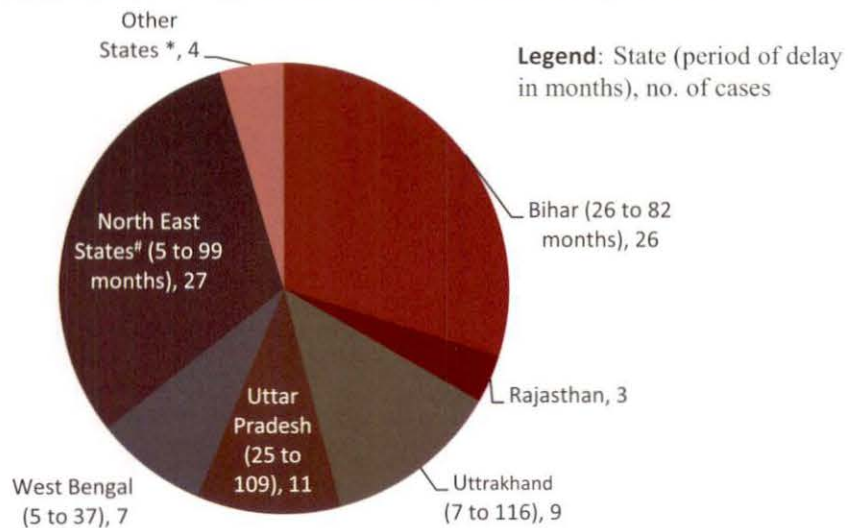

\*Includes one case each from Telangana, Gujarat, Goa, Maharashtra

# includes Assam-11, Arunachal Pradesh-1, Mizoram-2, Sikkim-3, Tripura-8, Meghalaya-2

It was noticed that position of land acquisition cases was worst in Bihar where 26 cases were delayed ranging between 26 to 82 months and out of which 17 cases were still pending as of December 2014.

MHA, in its reply accepted (July 2015) the observations/recommendations by stating that they have issued a comprehensive guidelines to all CAPFs on the basis of audit observations in June 2015 in the matter of acquisition of land and execution of work. MHA further stated that on the basis of request made by CAPFs, whenever any case of substantial delay/problem faced in land acquisition is reported by CAPFs it has always been taken up with the concerned State Government by MHA at higher level to sort out the issues causing delay in acquisition of land. Reply was not acceptable as substantial delays in land acquisition cases on the part of state governments indicates that intervention by MHA was not at appropriate level due to which issues relating to land acquisition between CAPFs and state governments were not timely sorted out.

### 3.1.1 Revision of cost in land acquisition cases

As the state governments were to decide the cost of land to be paid by CAPFs, it was noticed that from time to time they kept on increasing the cost of the land. In 36 cases out of 132 selected cases, audit noticed that the cost of the land was revised by the states from ₹ 105.10 crore to ₹ 223.57 crore (**Annex-3.1**). The state-wise revision of cost is detailed in Chart-3.3.

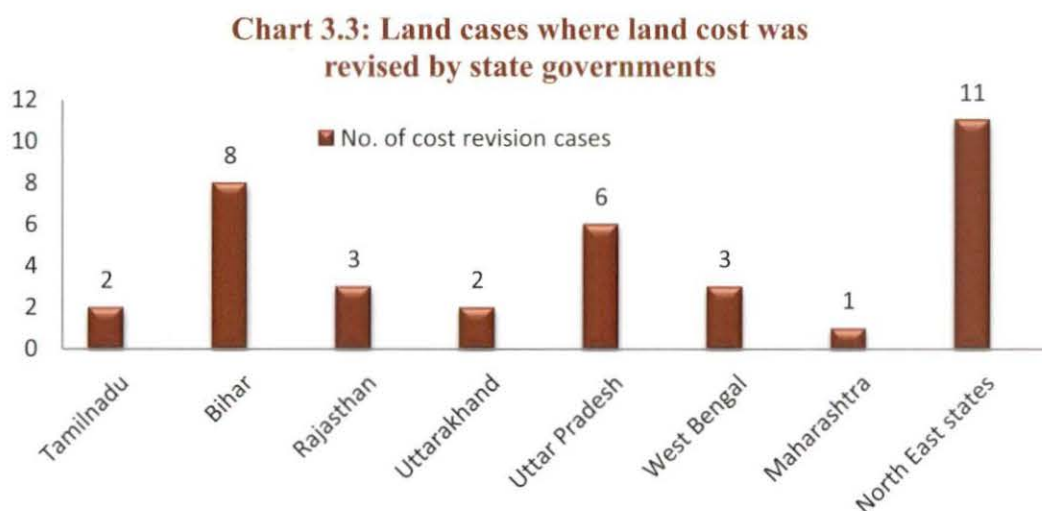

In seven cases, the revision of cost took place more than once. In two cases, it was noticed that the increase was more than 1000 *per cent* from the original cost of the land.

#### RECOMMENDATION:

MHA may facilitate CAPFs in acquiring land on timely basis by resolving administrative issues with states, by putting in place a structured mechanism of regular interactions at appropriate levels.



Some case studies in land acquisition are detailed below:

### Case Study – 3.1

One Battalion of AR in Shangshak, Ukhrul, Manipur was holding 445.23 acres of land since 1991. In addition, they were occupying an adjacent private land measuring 13.051 acres. In October 1996, the Manipur State Government fixed a value of ₹7.00 lakh for acquisition of this private land. This was not done by AR. Later in 2003, land owner approached the Imphal Bench of Guwahati High Court which directed the AR to pay compensation. Accordingly, AR in August 2012 paid compensation of ₹ 30.54 lakh. Despite being a Central Government organisation, AR kept private land since 1991. Moreover, they did not legally acquire the land at a cost of ₹ 7.00 lakh when it was offered by the state in 1996. Thus, they not only violated the law but had to also pay extra compensation of ₹ 23.54 lakh.

Assam Rifles accepted the audit findings and stated that the land acquired in excess of MHA's authorisation would be utilised in future. They further agreed to strictly adhere to the norms as fixed by MHA/Government of India, in future.

### Case Study – 3.2

AR in November 2008 against authorization of 80 acres, requested Assam State Government to acquire 150 acres belonging to a private land owner to set up a Battalion Headquarter at Jorhat, Assam. Though AR was aware of encroachment on the land, it deposited the cost of land amounting to ₹7.09 crore with the State Government in September 2011 without ensuring that the land was made free from encroachment by the state government. Due to this, the encroachment free land measuring 149 acres only could be taken over in December 2013 i.e. after more than 2 years from the date of deposit of money with State Government. Moreover, due to acquisition of land in excess of authorization norms, excess expenditure of ₹ 3.28 crore was incurred.

### Case Study – 3.3

MHA (November 2004) approved KLP for setting up of a unit of BSF in Guwahati, Assam. As per BSF board proceedings, 125 acres of land was needed. But BSF in May 2006 approached the Assam Government for acquisition of private land measuring 85 acres at Piyabari, Assam. They subsequently (September 2006) made a requisition for another piece of land measuring 40 acres. The MHA in August 2007 accorded approval for ₹ 5.77 crore towards the cost of 85 acres of land. Owing to the general public unrest in the state, the Assam Government after 6 years (June 2013) handed over a piece of land measuring 33.05 acres (cost ₹ 3.76 crore) at another location called Panbari. Audit found that the land had not been put to use. Thus, the setting up of unit envisaged in November 2004 was yet to materialize at the intended location. Moreover, the balance amount of ₹ 2.01 crore was lying with the State Government since August 2007.

DG, BSF, admitted the observation by stating that acquisition of land depended upon the availability and strategic/security requirements. Hence, in some cases, the area of the land may be excess or less than the authorization.

### Case Study- 3.4

Two BSF Battalions and a Sector Headquarters were functioning from a location at Roshanbagh, West Bengal. The area of the campus (75.52 acres) was even less than the area stipulated by MHA (77.19 acres) for a single Battalion. BSF in 2003 asked West Bengal State Government to acquire a nearby land measuring 43.53 acres for shifting one of these Battalions. Accordingly, the State Government in July 2003 asked BSF to deposit ₹ 77.86 lakh. In August 2003 they also cautioned the BSF that the estimate would become invalid in case of failure to deposit money by 11 December 2003. Despite this, the BSF deposited the amount only after the due date, on 22 December 2003 though MHA had accorded approval on 5 December 2003. Subsequently in October 2004, the State Government asked BSF to deposit additional ₹ 41.10 lakh since earlier land acquisition proceeding had lapsed due to revision of cost. The land could not be acquired subsequently as land owners did not accept the compensation amount forcing the State Government to revise the compensation amounting to ₹ 5.22 crore which was not accepted by BSF.

The State Government intimated (March 2013) to BSF about estimated cost of ₹ 22.41 crore for acquisition of another land measuring 75.72 acres at Balarampur, West Bengal. However, the same was yet to materialise as State Government in September 2013 decided to allot only 30 acres per battalion. Due to this, despite MHA's approval in June 2014, the land acquisition initiated prior to 2003 remained inconclusive and the 2 Battalions and the Sector Headquarters continued to function from the same location till date.

Audit did not come across any evidence of persuasion with the State Government at higher levels though the land acquisition case remained unresolved for the last 11 years.

BSF stated that land acquisition by State Government department could not finalize due to increase in demand of compensation by land owners and resulting in litigation. BSF took considerate decision for not paying high compensation. Reply was not acceptable as the position taken by BSF had not resolved the issue so far.

### Case Study- 3.5

To set up a Battalion Headquarters for SSB at Khaprail, West Bengal, MHA in January 2007 approved the KLP. On requisition from SSB for acquisition of 74.49 acres of private land at Khaprail, West Bengal, State Government in July 2008 asked SSB to deposit tentative cost of the land amounting to ₹ 8.04 crore. With MHA's approval, (August 2009) SSB deposited (November 2009) the amount. The State Government again in November 2010, asked SSB to deposit the balance cost of land amounting to ₹ 8.07 crore as cost was ₹ 16.11 crore. Though MHA approved the balance amount in July 2011, SSB deposited the same with the State Government only in September 2011 despite knowing that the time limit of one year for deposit of cost of land was over on 19 August 2011. Consequently, SSB had to make a fresh requisition (December 2011) and the land proceeding had to be initiated afresh. In September 2013, State Government intimated its decision to allot only 30 acres of land for setting up of a Battalion. Though SSB without MHA's approval conveyed their acceptance, the land was yet to be allotted

and the Battalion continued to function from rented accommodation. SSB paid rent of ₹ 58.82 lakh from April 2008 to March 2014. Moreover, the proportionate excess cost of ₹ 9.62 crore paid by the SSB remained with the state government for 13 months (September 2013 to October 2014).

The SSB stated that after MHA's sanction in July 2011 the process of getting allotment of fund and the drawl of money took time. There was, however, no justification for 9 months taken in obtaining sanction of MHA, though the state government in November 2010, itself had communicated the time limit within which the amount had to be deposited.

### Case Study – 3.6

Government of Tamil Nadu (GoTN) issued A1 notification<sup>1</sup> (February 2009) for 100 acres of land in Sivagangai District for CISF. It fixed the cost at ₹ 10.03 crore in April 2012 which was paid by CISF in February 2013. Audit noticed that the value as per revenue records in and around the area as on notification date was only ₹ 52,000/- per acre, which was endorsed by the Tahsildar, Karaikudi. Accordingly the land cost should have been ₹ 0.60 crore. CISF failed in pursuing the state government in fixing the price at prevailing rate at the time of issue of notification which resulted in excess payment of ₹ 9.43 crore. Despite payment, the title of the land was yet to be transferred by the state government.

CISF stated (October 2014) that the balance of ₹ 9.73 crore was paid after getting concurrence from Head Quarters as GoTN fixed the rate at ₹ 23 per square feet prevailing in 2010. The process of land transfer was pending as the value was yet to be finalized by the State Government. CISF further stated that Tahsildar, Karaikudi had mentioned the total cost of land as ₹ 0.60 crore without the knowledge of the District Collector and he was not authorized to fix land value since it was in the purview of Collector. The reply of the department was not tenable since CISF failed to pursue the state government in fixing the price at prevailing rate at the time of issue of notification.

## 3.2 OTHER IRREGULARITIES IN LAND ACQUISITION

During examination of land acquisition cases, audit came across other irregularities viz. land acquisition without approval of KLP, without constitution of Site Selection Committee, improper survey before initiating the proposal, acquisition of encroached land etc. These irregularities are discussed in subsequent paragraphs.

<sup>1</sup> A1 notification: Whenever it appears to the appropriate Government that land in any locality is needed or likely to be needed for any public purpose, a notification to that effect, shall be published in the *Official Gazette* and in two daily newspapers and the Collector shall cause public notice of the substance of such notification thereupon and the giving of such public notice, being hereinafter referred to as the date of the publication of the notification) (Section 4(1) of Land Acquisition Act 1984 and 2013

### 3.2.1 Improper survey before initiating the proposal

- The Site Selection Committee (SSC) constituted by SSB in January 2005 for the land acquisition of 83.5 acre at Lakhimpur Kheri, Uttar Pradesh failed to notify the patches of non-acquired land within the site worth ₹ 938.42 lakh.

SSB in its reply (June 2015) stated that the discrepancy has been noticed at the time of physical possession. Since acquisition of interspaced patches is unavoidable, proposal for their acquisition has been initiated and has been sent to MHA for sanction.

- MHA sanctioned SSB ₹ 16.08 lakh in 2008 for acquiring land measuring 2.21 acres at Maharajganj (UP). It was subsequently found that the land was mortgaged to a bank in lieu of loan taken by the farmer and thus could not be acquired. It was evident that proper survey was not conducted by the SSB before initiating the proposal of acquisition of land.

SSB in its reply (June 2015) stated that the discrepancy could be noticed during acquisition process and presently fresh proposal for a new piece of land had been initiated.

- NSG took possession of 5 acre land for ₹ 29.75 lakh in January 2009 from Airport Authority of India (AAI) on lease basis at IGI Airport, Delhi, which was a low lying area and undertook preliminary work worth ₹ 12.25 lakh. However, NSG in February 2009 requested AAI to allot another piece of land in lieu of this land. AAI offered another piece of land of 5 acre in April 2009. Thus, initiation of land acquisition process without conducting the survey not only delayed the acquisition but also resulted in wasteful expenditure of ₹ 12.25 lakh. NSG (October 2014) replied that out of the expenditure of ₹ 12.25 lakh incurred on first piece of land, items worth ₹ 2.33 lakh were retrieved and used at other places. It was evident that rest of the expenditure amounting to ₹ 9.92 lakh became wasteful expenditure.

- SSB acquired 0.7 acre land in Mahipalpur, Delhi from DDA in April 2007 at a total cost of ₹ 57.59 lakh without survey of land. When DDA asked SSB to take possession of the land, SSB inspected the land and found that the said land was approximately more than 15 meter below the normal ground level and requested DDA to allot another piece of land. After long correspondence, DDA in December 2010 allotted alternate piece of land, resulting in delay of three years.

SSB stated that DDA allotted land as per their suitability and availability and when it was seen that the land offered was not suitable, an alternate land was allotted. The reply was not tenable as SSB was required to inspect the land before finalizing the acquisition. It is worth mentioning that in this case, a different land was acquired from what was finalized by the force initially.

- NSG acquired 23 acres of land for establishment of Regional Hub in Mumbai. It was noticed that there was not only encroachment but the acquired land also had a

high tension wire passing over it. NSG had to shift the high tension wire which would cost an additional amount of ₹ 3.74 crore.

MHA in its reply (July 2015) accepted the observation by stating that for establishment of NSG Regional hub at Mumbai, land was provided by the Government of Maharashtra free of cost.

### 3.2.2 Improper lease deed

Analysis of five cases of BSF, ITBP and CRPF in respect of acquired land in Kerala on lease basis revealed that no clause was included in the lease deed for its extension after the expiry, which was in contravention of the guidelines issued by MHA. The details of land leased out by Kerala Government to BSF, ITBP and CRPF for establishing their units on lease rent basis were as detailed below:

**Table 3.2: Details of land on lease rent basis in CAPFs**

S. No	Land details	Force	Lease Rent	Lease Period	Date of lease deed	Status
1.	15 acres of land at Muttathara Village in Thirvananthapuram district for establishing a Sector Headquarters for BSF	BSF	₹1000 /acre/annum	30 years	20.9.2011	Land in possession of BSF
2.	55 acres of land in Chekkiad Village Vatakara Taluk in Kozhikkode District for establishing a BSF Battalion at Nadapuram	BSF	₹100 /acre/annum	30 years	5.1.2012	Land in possession of BSF
3.	60 acres of land at Kainoor in Thrissur District for establishing a BSF Battalion	BSF	₹100 /acre/annum	50 years	13.7.2010	Land in possession of BSF
4.	50 acres of land was allotted at Nooranad in Alappuzha District for establishing a ITBP Battalion	ITBP	₹100 /acre/annum	30 years	25.9.2013.	Land in possession of ITBP
5.	40 acres of land at Chakkittapara in Kozhikkode District for establishing a CRPF Battalion	CRPF	₹100 /acre/annum	30 years	10.7.2013	Land in possession of CRPF



Further, the lease deed was in the form of an 'order of grant of State land for temporary occupation for non-cultural purposes'. The land granted by the Government of Kerala on lease to CAPFs was taken possession of by the forces and new construction worth crores of rupees was taking place on these lands. The conditions in the Lease Agreements were thus detrimental to the interest of the force.

MHA stated (July 2015) that in its earlier guideline validity of lease was 99 years. Various States have prescribed their own land lease agreements. As such a standard lease agreement cannot be prescribed for all the States. However, land lease agreement is being vetted by Ministry of Law & Justice before CAPF sign the same with concern State Governments so that interests of CAPFs are safeguarded. However audit noticed that the earlier lease deeds executed up to March 2014 were not vetted by Ministry of Law & Justice and MHA. MHA has only recently (July 2015) instructed all CAPFs that lease deeds should be executed after vetting from Ministry of Law & Justice and MHA.

### 3.2.3 Non-construction of boundary wall

It was noticed that in 15 land acquisition cases, boundary wall was not constructed, which was in contravention of guidelines of MHA. An interesting case of encroachment of CRPF land due to non-construction of boundary wall in violation of guidelines of MHA occurred in Bhilai has been discussed as case study below:

#### Case Study - 3.7

CRPF planned to set up a Group Centre at Bhilai in 1970 and ₹ 2.19 lakh was paid to the Bhilai Steel plant in February 1971 for the purchase of 250 acres of land, but against which only 232.02 acres of land was actually handed over to the CRPF in April 1972. Audit noticed that proper demarcation of land by erecting boundary pillars was not done by CRPF and the land was not transferred in the name of Group Centre, CRPF, Bhilai from Bhilai Steel Plant, in the revenue records. Later, CRPF withdrew its personnel over a period of time for anti-insurgency duties in the North East. Thereafter, CRPF left the unprotected land at the mercy of land encroachers. Later in October 2012, CRPF decided to establish Battalion camping site/Group centre at Bhilai to cater for the units deployed in Chhattisgarh. On physical survey, it was found that almost the entire land had been parcelled out into plots and sold by some agencies. Lack of proper demarcation of land by erecting boundary pillars, non-monitoring the possession of land since 1977 and non-construction of boundary wall resulted into massive encroachment and selling out of land by some agency. Thus, the irresponsible act of CRPF in contravention of guidelines of MHA had resulted in dispossession of valuable land.

CRPF stated (July 2014) that the State Government was being approached to carry out joint survey to establish the fact/fix responsibility to the agency who had parcelled out the land and to carry out an investigation to this effect. CRPF further stated (June 2015) that the documentary evidence has been called from concerned agencies and will be submitted on receipt.

### 3.2.4 Improper documentation

It was noticed in 18 cases (**Annex-3.2**), that the sale deed/mutation was not executed which was in contravention of MHA guidelines. All these land acquisitions were meant for further construction activities which were to be started only after the complete documentation and transfer of land and Improper documentation would hamper the construction activities. MHA did not offer their comments.

### 3.2.5 Non-possession of land

- During site visit in village Maujpur (Alwar), Rajsathan, audit noticed that in the allotted land, 11 Khasras<sup>2</sup> were not transferred to SSB while locations of these Khasras were within the site. This may create dispute in future and these Khasras should not be left out from acquisition due to security reason also as their location is within the acquired area.

SSB accepted (June 2015) that such discrepancy could not be noticed in initial stage of proposal when all detailed revenue records were not available at initial stage and hence this goes through entire acquisition process. Proposal for khasras left in earlier acquisition process is now processed.

MHA in its reply (July 2015) accepted the observations/recommendations by stating that they have issued a comprehensive guidelines to be followed by all CAPFs on the basis of audit observations in June 2015 in the above matter of acquisition of land.

## 3.3 NON-UTILISATION OF ACQUIRED LAND

As per General Financial Rules, the government money spent should fulfill the intended purpose for which the amount was sanctioned. Audit noticed that in 13 cases, land costing ₹ 49.11 crore was not put to use. (**Annex-3.3**). The land acquired by CAPFs in these cases was for construction of different types of establishments but the land was not utilized for the intended purposes till date. CAPFs stated (June 2015) that one of the reasons for not utilization is court cases and litigations.

## 3.4 EXCESS PAYMENT TO STATE AUTHORITIES

Audit noticed that in the following cases, CAPFs incurred an excess expenditure of ₹ 21.65 lakh in acquiring the land. The details are given in the table.

<sup>2</sup> Land identification number with specific ownership recorded in the land revenue record of the state government

Table 3.3: Details of excess payments for land paid to states by CAPFs

(₹ in lakh)

Force	Particulars of land acquired	Excess amount paid	Audit observation
SSB	Acquisition of land, Pithoragarh, Uttarakhand	12.65	SSB deposited ₹ 15.15 lakh for 3.17 acre of land to district authorities. The proposal was cancelled by the SSB and a fresh proposal for acquisition of 1.24 acre of land costing ₹ 2.50 lakh was approved in May 2014. The balance of ₹12.65 lakh was still lying with the state Government. SSB accepted the facts and stated that matter is being pursued with district/state authority.
BSF	Acquisition of 65.343 acre land in Lucknow	9.00	BSF deposited ₹ 2.99 crore with District Revenue Authorities. After payment of compensations, awards and adjustment of other dues, an amount of ₹ 9.00 lakh had been lying with the District Collector, since July 2012. No efforts have been made for refund of this amount. BSF in its reply (June 2015) stated that district Land Acquisition authority had been approached for refund.
<b>Total</b>		<b>21.65</b>	

### 3.5 CONCLUSION

It was seen that the state of acquisition of land in CAPFs was not satisfactory. Audit found neither in MHA nor in CAPFs any effective land acquisition monitoring system resulting in delay in acquisition/non-acquisition of land even after deposit of land cost with the state government. Further, there was absence of any structured interaction between higher authorities of CAPFs/MHA and state revenue departments, for sorting out issues causing delay in acquisition of land. Audit examination found that there were abnormal delays in 66 *per cent* land acquisition cases, in the worst case up to nine years. Besides, there were instances of violation of MHA guidelines/norms during land acquisition, inadequate survey before initiating the proposal, etc.

#### RECOMMENDATION:

MHA may revisit the time frame of One year and seven days fixed for land acquisition by CAPFs, as this was not met in any of the cases scrutinised by audit. CAPFs need to ensure during survey that land was free from all encumbrances.



## CHAPTER – IV

# Construction Activities - Issue Wise

Construction activities involve the overall planning, coordination and control of a project from beginning to completion in order to produce a functionally and financially viable project. This chapter contains audit findings in respect of 710 sanctioned works amounting to ₹ 3257.37 crore. An attempt was made to bring out deficiencies in all the stages of the lifecycle of a construction project and are described in that order in this chapter. These works were carried out by the executing agencies, and the onus for majority of the deficiencies pointed out rests with executing agencies. Aggregate picture and macro analysis of the observations in this chapter are presented PWO-wise (**Chapter-V**) and force-wise (**Chapter-VIII**) too.

The process of construction works starts from selection of executing agency after necessary approvals to handing/taking over of site after construction as depicted in a representative chart below. Main audit findings relating to construction work are explained subsequently.

**Chart 4.1: Processes of Construction Works\***

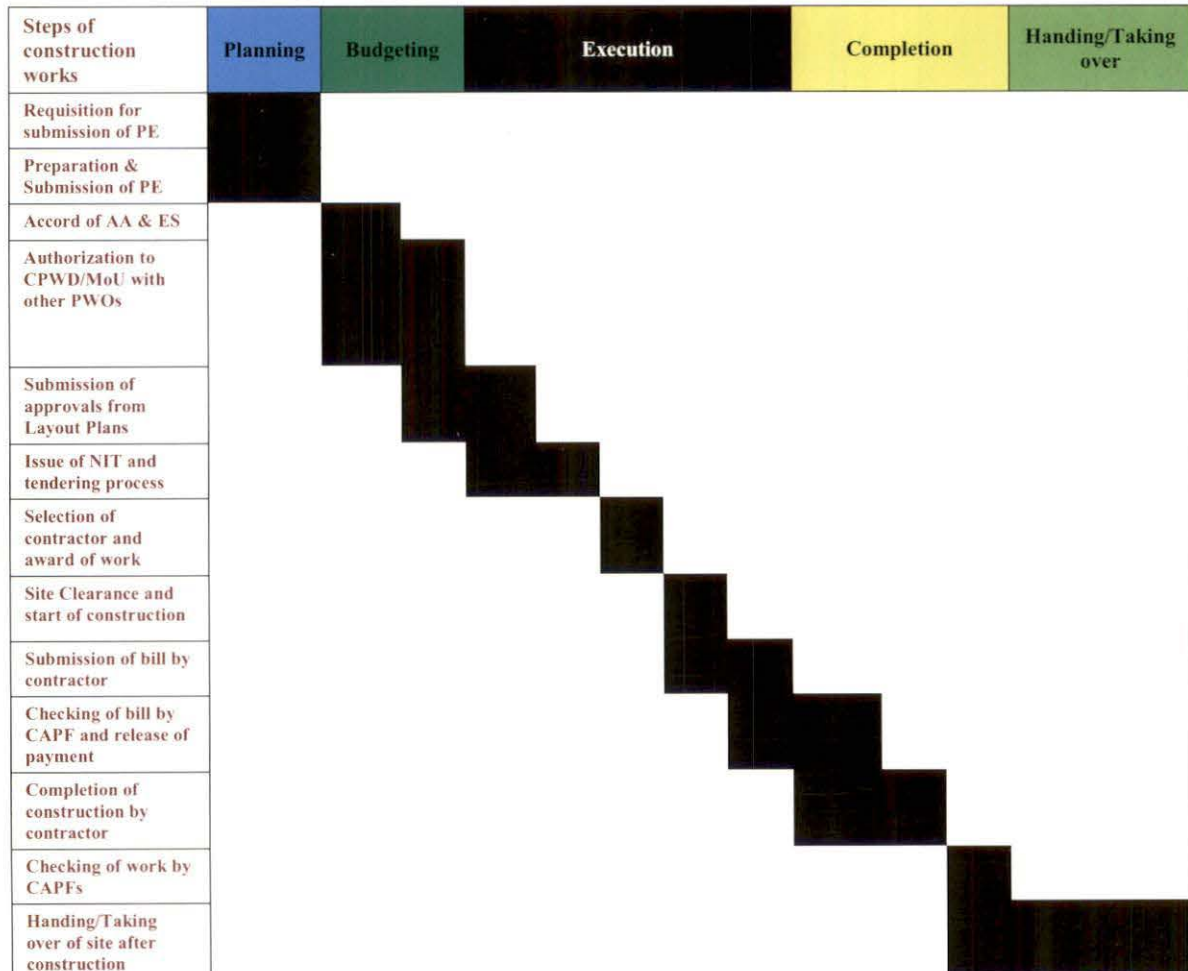

\* Chart explain the different stages of construction works linked with activities of those stages

## 4.1 SUBMISSION OF PRELIMINARY ESTIMATES BY EXECUTING AGENCY

### 4.1.1 Assessment of requirement while preparing Preliminary Estimates (PE)

Audit noticed that proper assessment of requirement was not done in following cases which resulted in unfruitful expenditure of ₹ 40.82 crore:

- MHA sanctioned work of construction of 108 residential quarters for CISF including 12 Type-V at CISF campus, Greater Noida, Uttar Pradesh in March 2010 at an estimated cost of ₹ 15.35 crore to be executed through NBCC. However, CISF conveyed sanction to NBCC of construction of only two Type-V quarters in May 2010. In June 2010, CISF revised the sanction of Type-V quarters from two to five. In February 2011, CISF again revised the sanction of construction of Type-V quarters from 5 to 12 as originally sanctioned by MHA. NBCC refused to construct the additional quarters at the same rate and stated that separate work was to be awarded. Accordingly, work of construction of seven type-V quarters was awarded in February 2012 at ₹ 2.31 crore which was 49 *per cent* above the cost index prevailing during that period. There was no justification available in files for changing the number of Type-V so many times. It resulted in avoidable expenditure of ₹ 68.88 lakh.

CISF stated (June 2015) that 12 type-V quarters were considered for Special Security Group (SSG) & Government Building Security (GBS) Group and phase wise construction work was taken up considering the availability of funds and the actual requirement of the recipient units. Reply was not acceptable as MHA originally sanctioned ₹ 15.35 crore for construction of 108 quarters which included 12 type-V quarters as per actual requirement of the recipient units of CISF.

- Assam Rifles (AR) submitted the requirement of Type-II, III and IV quarters (total 64 in number) in Delhi to MHA in its Annual Action Plan 2003-04 with an estimate of ₹ 4.50 crore. Audit noticed that AR has no field formations in Delhi. DGAR was asked for justification of family quarters in Delhi by MHA, but no reply was furnished by AR. However, MHA approved construction of residential quarters worth ₹ 33.30 crore in Delhi. Construction started in 2008-09 but was yet to be completed.

AR stated (June 2015) that the personnel of AR were from different parts of the country so it was decided to offset some accommodation from authorisation of family accommodation of AR in North East to Delhi and sanction was obtained from MHA. Reply was not acceptable as AR was mainly deployed as border guarding force for North East region and no unit had been deployed/posted in Delhi, so construction of residential accommodation for AR in Delhi was not justified.

- DG, ITBP in April 2013 accorded approval of six works for ₹ 76.52 lakh for a Transit Camp at Jalukbari, Guwahati. Out of six different sub-works, three works were dropped and instead another work of construction of additional suites was taken up, indicating the loose and arbitrary manner in which the estimates were drawn up.
- Hindustan Prefab Limited (HPL) in April 2010 took up the construction of 7 Kilometres original road with a bridge at Sukhovi, Nagaland for ₹ 13.87 crore. After completing the road work on either side of the bridge, HPL sought (March 2014) for additional fund of ₹ 1.42 crore to connect the road by constructing the bridge. This enhancement in the cost of the work was attributed to increased length of the bridge than that was envisaged in the preliminary estimates (PE). AR, however, decided (August 2014) to leave this un-connected road incomplete after incurring ₹ 6.06 crore as they assumed that requirement for same would occur only after 8 to 10 years (November 2014). Records also revealed that the road got damaged due to rain and was not in motorable condition any more as shown below:

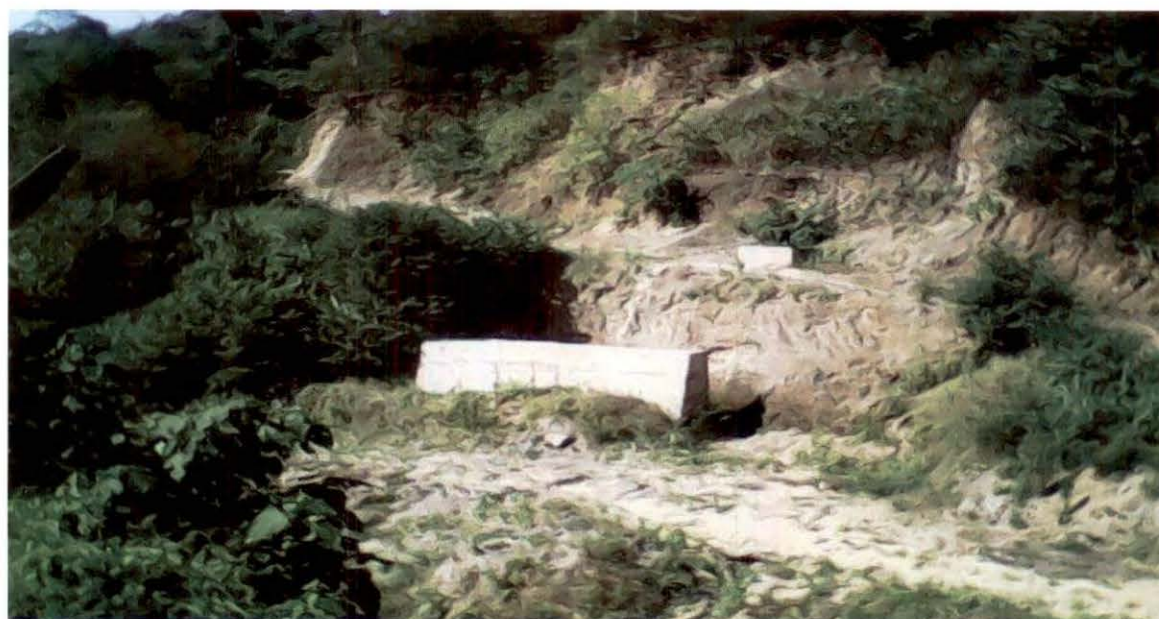

**Picture 4.1: Incomplete Bridge and unconnected road at Sukhovi in Nagaland**

Assam Rifles stated (April 2015) that the said work was taken up in anticipation of additional training Battalion supposed to be sanctioned in 12<sup>th</sup> five year Plan. They further added that the road will provide access to the training battalion expected to come up in the area after 3-5 years time. Reply was not acceptable as the battalion was yet to be sanctioned by Government of India.

#### **4.1.2 Failure in pre-construction stage survey**

Audit scrutiny of records revealed that in the following works, proper planning by the client as well as executing agency was deficient:

Table 4.1: Details of works having deficient pre-construction stage survey

S No	Particulars of work	Irregularity
1.	Construction of magazine at GC, CRPF, Bilaspur by CPWD with estimated cost of ₹ 29.78 lakh.	CPWD did not mention about a high tension wire in the drawings which resulted in excess expenditure of ₹ 23.11 lakh for shifting the same. CPWD did not offer their comments.
2.	Construction of 50 bedded hospital in Bhopal, for CRPF by CPWD for ₹ 1281.41 lakh	Safety provisions, power backup system, fire alarm, fire fighting system, refrigerator for mortuary, disposal of biochemical wastage etc. were not included during planning stage by CPWD. Separate preliminary estimate amounting to ₹ 1.98 crore has been prepared by CPWD for sanction of these works.  CRPF in its reply stated that sanction was being accorded and in future all necessary provisions would be incorporated in preliminary estimate. CPWD did not offer their comments.

### 4.1.3 Requisite approvals from local authorities

As per section 2.7 of CPWD Manual, Lay Out Plan (LOP) and drawings in respect of each establishment should be prepared as per the suitability/norms and approved by the competent authority of the client (CAPF). Municipal/Local Bodies/Development Authority were to be approached by the PWOs, well in time for obtaining necessary approvals prior to NIT/commencement of work. Further, any subsequent alterations in LOP and drawings also need approval from these authorities.

In 463<sup>1</sup> works, it was noticed that in 341 works (73.6 per cent) approval of drawings, lay out plans etc. from the local authority were not taken before issue of NIT by executing agencies. Further, in 234 works (68.6 per cent) contracts were awarded to contractors without taking approvals (**Annex-1.3**). Approval of local authorities for LOP was not obtained in 66 works even after their completion.

CPWD accepted the audit observation and stated (April 2015) that designs and drawings of buildings were prepared by Sr. Architect of CPWD and conforms to norms set by local bodies/authorities. Application for the approvals of designs and drawings of buildings were submitted to local authorities where the area falls within municipal limit. Reply was not acceptable because provisions of CPWD works manual had not been followed. Moreover, in absence of approval of LOP, possibility of declaring the completed

<sup>1</sup> 463 works out of total selected 710 works. The balance works does not require permissions as these works were not new works and mainly related to repair and renovation works.

construction as unauthorised by the local authorities later on could not be ruled out. PWOs except CPWD did not offer their comments.

Three examples are given below in which approvals from the local authorities were not secured in time.

### Case Study - 4.1

Assam Rifle awarded a work of 32 quarters and hostels at Dwarka, New Delhi to EPIL in July 2003. Due to increase in cost index and scope of work, estimated cost was revised from ₹ 4.50 crore to ₹ 7.30 crore in December 2005. EPIL though did not seek the approvals from the local authorities, awarded the work to a contractor in June 2006. The contractor started the construction of boundary wall and insisted on approvals from the local authorities for taking up the work. EPIL failed in getting approvals in time. The approvals from the local authorities were received in July 2007 and by that time the contractor refused to work on the rates quoted in June 2006. MHA had to give revised sanction of ₹16.85 crore in February 2009 for the same work. Thus, poor planning resulted in price escalation of ₹12.35 crore and the work originally planned for completion in September 2007 was not handed over up to June 2015, by the EPIL.

### Case Study - 4.2

In works of SSB<sup>2</sup> at Jwalamukhi with original estimated cost of ₹ 4.77 crore executed by CPWD, audit noticed that execution of work was started without obtaining mandatory approval of building plan from Nagar Panchayat as well as NOC from NHAI. After six months the works were foreclosed. Revised estimates amounting to ₹ 6.54 crore were prepared in February 2014 which resulted in cost escalation of ₹ 1.77 crore.

The executing agency admitted that delay in getting approvals from authorities lead to cost escalation. SSB in its reply stated that the approval from the NHAI was received in November 2010 and thereafter the approval to the plans & LOP was conveyed in January 2011 by the local body. Reply is not acceptable as SSB/CPWD should have pursued the necessary approvals well in time prior to NIT/commencement of work, as the delay in obtaining approvals had resulted in foreclosure of work and consequent cost escalation in subsequent tendering.

### Case Study - 4.3

CPWD received a request from NSG for Construction of office and residential complex at Samalkha Camp, New Delhi in July 2002 with a request to obtain conceptual approvals from authorities simultaneously as obtaining approvals from local bodies was time consuming process. In response, CPWD submitted a Preliminary Estimate (PE) of ₹ 10.76 crore to the NSG in October 2002. The PE was for four storied (G+3) structure and for building works. It was noticed that PE was revised six times by CPWD primarily

<sup>2</sup> Construction of boundary wall, internal roads, underground water tank and other development works, Type-IV/04Nos. qtrs.(Double storied) at Jawalamukhi, Type-III/08Nos. qtrs. (Four storied) at Jawalamukhi and Type-II/20 qtrs



due to delay in obtaining approvals from Municipal Corporation of Delhi. Finally in March 2011, CPWD submitted revised PE of ₹ 47.42 crore which was sanctioned in July 2011. Approvals for construction of building having G+4 were still pending and the work was still incomplete (June 2015). Thus, due to delay in obtaining the approval of the MCD, the estimated cost of the building had increased from ₹ 10.76 crore to ₹ 47.42 crore and project started in July 2002 remained incomplete after 13 years.

NSG in its reply (June 2015) accepted the observation by stating that the work could not be started in time for want of approvals from local authorities. It further stated that it was not the client but the executing agency which was supposed to obtain approval from local bodies.

#### 4.1.4 Preparation of incorrect Preliminary Estimate

Audit scrutiny revealed many shortcomings in the preparation of preliminary estimates (PEs) by executing agencies. CAPFs were also not following proper checks in analysing the PEs before according administrative approvals. The following instances depict the irregularities noticed in preparation of PEs:

**Table 4.2: Details of works where incorrect PEs were prepared**

Irregularity	Audit observation
<b>Adoption of incorrect rate by NPCCL</b>	In the Delhi Plinth Area Rate (DPAR), separate rates are provided for different types of buildings e.g. school, hostel and residential. It prescribed two rates for 'higher specification items' and 'normal specification items'. Buildings of Assam Rifles come under 'normal specification items'. But in PE, NPCCL considered 'higher specification items' on some items arbitrarily. Due to this, PEs were inflated by ₹ 94.84 lakh. <b>(Annex-4.1)</b> . NPCCL did not offer their comments.
<b>Consideration of higher rate of Works Contract Tax (WCT)</b>	In one work <sup>3</sup> executed in Manipur, NPCCL made provision for 'Works Contract Tax' at a rate of 12.5 <i>per cent</i> instead of prevailing rate of 5.6 <i>per cent</i> in the Manipur state. It resulted in inflated PE by ₹ 23.26 lakh. In reply, Assam Rifles admitted the audit observation by stating that the variation in deduction of WCT was due to late receipt of WCT notification from respective state government.

<sup>3</sup> Construction of 01 Block of 3 Nos Single Men Barrack for 06 NCOs and 60 Ors (G+II) and 01 no. Admn Block (G+1) for 21 AR

Irregularity	Audit observation
<b>Application of different cost index</b>	Hindustan Prefabs Limited (HPL) applied different cost index while framing the PE for construction of two works <sup>4</sup> of AR in Manipur though both the works were executed at the same time. Due to this, the estimated cost of the work was pushed up by ₹ 21.66 lakh. HPL did not offer their comments.
<b>Wrong calculation of Plinth Area by CPWD</b>	<p>In the work construction of administrative and training block for Group Centre and Academy for CRPF at Kadarpur, Gurgaon, the CPWD had approved the PE for ₹13.10 crore in December 2002 taking into account the plinth area as 8771 square meter (sqm) based on conceptual architectural drawings prepared by the Senior Architect, CPWD in October 2002. The work was awarded to contractor by CPWD at the tendered cost of ₹ 9.28 crore. The work was temporarily suspended in March 2007 as the tendered cost was exhausted. The Contract was foreclosed in August 2008. Revised PE amounting to ₹ 24.62 crore, considering the final working drawings as 12322 sqm, was submitted to the CPRF by the CPWD in January 2007, the same was sanctioned by the MHA in March 2009. On being sought clarifications on wrong calculation of plinth area in preparation of estimate, the CPWD in their response stated that there was certain inadvertent error in calculation of floor area shown in conceptual drawings, which was approved by CRPF. It was further stated that PE for an amount of ₹ 13.10 crore was framed by taking area as 8771 sqm instead of the actual area of 12322 sqm. After receiving revised AA/ES, the balance work was awarded (August 2009) to another agency at their tendered cost of ₹ 4.14 crore, against which payment of ₹ 6.20 crore have been made and work stands completed in October 2010.</p> <p>CRPF in its reply (June 2015), accepted the observation and decided to issue advisories to the defaulting officers of CPRF as well as CPWD.</p>
<b>Wrong inclusion of service tax on PMC</b>	In 13 cases ( <b>Annex-4.2</b> ), excess provision of budget of ₹ 1.30 crore was made in the PEs on account of wrong inclusion of service tax on project management charges (PMC) charged by the PWOs as PWOs were exempted from service tax with effect from July 2012. NBCC did not offer their comments.

<sup>4</sup> Construction of 1.5 km internal road for AR housing project of dwelling units at Kangvai, Manipur; five dwelling units type-V quarters for AR in two blocks at Kangvai, Manipur

### 4.1.5 Non-inclusion of items in Preliminary Estimates

Scrutiny of PEs of construction works revealed that in some cases, important items were not included in the PE.

**Table 4.3: Details of works with non-inclusion of items in PEs**

Irregularity	Audit observation
<b>Absence of provision for facilitating items</b>	Five works of AR involving ₹ 7.00 crore awarded during 2013-14 did not take off as of November 2014 though stipulated period for completion of the works were 60 to 67 <i>per cent</i> over. This was attributed to improper preparation of PE as no provision for approach road, dismantling of old building and site clearance was made. <b>(Annex-4.3)</b> . Assam Rifles admitted the audit observation (March 2015) stating that they would take due care to provide necessary provisions in the Preliminary Estimate.
<b>Absence of provision for energizing</b>	In one case, construction of 18 quarters (Jorhat, Assam) by NPCCL valuing ₹ 825.69 lakh could not be taken over by AR for 1½ years after its construction in July 2012 because no provision for energizing of 350 KVA transformers was kept in PE. Assam Rifles admitted the audit observation (March 2015) stating that they would take due care in preparation of PEs by incorporating provisions for all necessary services.
<b>Absence of Water Harvesting</b>	Audit examination revealed that the PWOs to whom AR entrusted their works did not comply with guidelines of AR to make provision in the estimate for water harvesting. This deficiency was observed in 100 <i>per cent</i> of the audited building works of AR <b>(Annex-1.3)</b> .

CAPFs in their reply stated that due to mandatory cut of 16.6 *per cent* on residential and 18.5 *per cent* on office work over DPAR estimates by MHA, certain development items required as per site requirement were deleted/not included. Reply is not acceptable as it indicates that either the development items were not required or they were included to inflate the PE which was later deducted by MHA without giving any reasons.

### 4.1.6 Delay in submission of Preliminary Estimates

There were no norms/time limits fixed either by MHA or by the PWOs for finalisation of PEs. Audit scrutiny suggested that on an average, five months were taken in submission of PEs by the executing agencies to CAPFs. However, in 173 out of 651 cases<sup>5</sup> (26.5 *per cent*) involving total sanctioned amount of ₹ 831.26 crore **(Annex- 1.3)**,

<sup>5</sup> In 59 cases out of 710 works, data was not available.

CPWD/PWOs as well as CAPFs took more than five months for the submission/finalization of PE. This had a cascading effect on the subsequent milestones, pushing the project backwards by several months. The agency wise position of time taken was as follows:

**Table 4.4: Details of works with delay in submission of Preliminary Estimates**

(₹ in crore)			
Name of the PWOs	Number of cases where time taken was more than average i.e. five month	Name of Force	Amount
CPWD	133	BSF-30, CISF-16, CRPF-39, ITBP-18, NSG-2, SSB-28	515.25
DEPARTMENTAL	4	AR-1, BSF-1, ITBP-1, NSG-1	0.95
NBCC	12	CISF-1, CRPF-10, SSB-1	220.44
NPCCL	20	AR-20	59.92
ECB	1	AR-1	0.72
EPIL	3	AR-3	33.98
<b>Total</b>	<b>173</b>		<b>831.26</b>

CPWD as well as PWOs did not offer their comments. However, CAPFs accepted (June 2015) the fact by stating that submission of PE well in time is the responsibility of the executing agencies. The Assam Rifles in their reply (April 2015) stated that they would fix a time limit of one month for the PWOs to submit the PE.

Some illustrative cases of delay in finalisation of PE in respect of BSF, CRPF and ITBP are detailed below.

#### **Case Study 4.4:**

For construction of Border Out Post for SSB at Maharajganj by CPWD, an Administrative Approval and Expenditure Sanction was issued (March 2012) for ₹ 421.82 lakh. Soil testing was carried out in October 2012. As per soil testing report, soil testing with variances needs to be carried out along with the comments from Banaras Hindu University (BHU). A fresh plan for soil testing was submitted in February 2013, by CPWD but sanction for revised proposal was not accorded by SSB even after lapse of 28 months.

SSB in its reply (June 2015) accepted the fact and stated that revised sanction was required in view of change in design of foundation due to poor soil condition but revised sanction could not be given due to limitation of Expenditure Finance Committee (EFC).

#### Case Study - 4.5

BSF did not furnish the details while requesting CPWD in January 2009 to undertake construction of Administration Block for BSF at Patgaon, Assam. CPWD on their part did not remind the BSF of their failure till February 2011. It took more than two years by BSF to provide the drawing to CPWD, which was attributed to the non-finalization of the same by BSF. In the intervening period the cost index increased by 28 *per cent*, pushing up the estimated cost of the work by ₹ 2.28 crore. Apart from the non-compliance with the codal formalities, the fact that the BSF did not ascertain the cause of non-preparation of preliminary estimate from CPWD for about 2 years indicated lack of monitoring by the BSF authorities.

BSF in its reply (June 2015) accepted the delay on its part and stated that efforts were being made to expedite early submission of PEs. It further stated that delay in this cited case was due to non-finalization of soil testing.

#### Case Study - 4.6

For construction of Combined Drill Shed one each at Raninagar and Baikuntapur, West Bengal, BSF returned the PE to CPWD for revision, 20 months and 17 months respectively, after the date of receipt. This was attributed to the modification in drawings prepared by BSF themselves. Owing to the upward revision of the cost index by 33 to 34 *per cent* in the intervening period (between the initial submission of the PE and the subsequent revision) there was increase in the estimated cost of the works by ₹ 1.50 crore.

#### Case Study - 4.7

For construction of Water Bound Macadam and re-carpeting of road at Lohitpur, Arunachal Pradesh, ITBP asked CPWD for submission of PE in March 2007 and again in January 2008. The Estimate for ₹ 1.93 crore prepared in July 2008 on the cost index of April 2007 was sanctioned in June 2009. The estimate had to be revised to ₹ 2.36 crore on the basis of cost index of April 2009, as tendered amount of the lowest bidder was higher than the sanctioned amount. The final PE was sent to ITBP in August 2009. These events delayed the project by more than 2 years and increased the cost of work by 22.27 *per cent*.

#### Case Study 4.8 :

Extension of Visitors Gallery and provision for various amenities at Attari Border (Wagah) was received from BSF by CPWD in June 2008. However, it was noticed that total five preliminary estimates were prepared and finally MHA issued sanction for ₹ 23.98 crore in October 2013. The technical sanction for ₹ 16.12 crore was issued by CPWD in May 2014. The work could not be started even after a lapse of six years of submission of proposal by BSF.

BSF accepted the observation and stated (June 2015) that due to improper response, the work was delayed and now the work has been awarded.

**RECOMMENDATION:**

CAPFs may fix time frame for furnishing of PEs by PWOs. This will help in reducing the time overrun during subsequent stages.



## 4.2 ADMINISTRATIVE APPROVAL & EXPENDITURE SANCTION

Administrative Approval (AA) is the formal acceptance of the proposals whereas 'Expenditure Sanction' (ES) is the sanction by the competent authority to incur expenditure. According to Rule 129 of GFR, no work should start without obtaining Administrative Approval & Expenditure Sanction (AA & ES), which is accorded on the basis of a PE prepared by an executing agency. No time limit has been prescribed by the MHA for according AA & ES.

Audit examination revealed deficiencies such as

- (i) Splitting up of work
- (ii) Delay in sanction of AA&ES
- (iii) Non-obtaining revised expenditure sanction, which are elucidated below:

### 4.2.1 Splitting up of main works

Rule 130 of GFR and CVC guidelines provide that a group of works which forms one project, shall be considered as one work. The necessity for obtaining approval or sanction of higher authority to a project which consists of such a group of work should not be avoided because of the fact that the cost of each particular work in the project is within the powers of such approval or sanction of a lower authority. The delegation of financial powers authorizes DsG and other officers of the respective forces like SDsG, ADsG and IsG to sanction projects related to construction activities up to a certain limit. The details are as follows:

**Table 4.5: Delegation of financial powers in CAPFs for construction works**

Details of Work	MHA	DG	Spl. DG	ADG
Major Works through CPWD or PWOs	₹ 5 crore to ₹ 20 crore	₹ 2 crore to ₹ 5 crore	₹ 1.5 crore to ₹ 2 crore	₹ 1 crore to ₹ 1.5 crore
Major works departmentally (where force has engineering wing) (Up to in each case)	-	₹ 60.00 lakh*	₹ 40.00 lakh	₹ 25.00 lakh
Major works departmentally (where force has no engineering wing) (Up to in each case)	-	₹ 10.00 lakh	₹ 8.00 lakh	₹ 5.00 lakh

\*Beyond ₹ 60.00 lakh, the works will be executed through PWOs.

It was noticed that instead of preparing one estimate for the project, it was split up into 2 to 8 works keeping the cost of each work within the limit of the delegated power of DG / MHA in order to avoid obtaining AA & ES from higher authorities.

Following works were split up by respective DsG of CAPFs/MHA in order to avoid the approval of higher authorities:

**Table 4.6: Details of works split up to avoid approval of higher authorities**  
(₹ in crore)

S. No.	Details of work	Amount of the sanction	Date of sanction
1. (i)	Upgradation of Quarters at NSG Garrison, Manesar	0.39	28.05.2008
(ii)	-do-	0.40	26.05.2008
2. (i)	Construction of toilet blocks at Manesar	0.07	04.02.2010
(ii)	-do-	0.60	04.02.2010
3. (i)	Upgradation of quarters during change of occupancy at NSG Garrison, Manesar	0.47	02.02.2012
(ii)	-do-	0.48	22.03.2012
4.	Construction of Group Centre for CRPF at Bahalgarh, Sonipat Haryana. (Split up into seven works)	166.00	24.09.2011
5.	Establishment of Battalion headquarter for BSF at Mathura, UP (Split up into eight works)	38.21	09.05.2013 to 24.09.2013
<b>Total</b>		<b>206.62</b>	

In case of construction of a new group centre for CRPF at Bahalgarh, Sonipat (S. No 5 above), consultant engaged by the NBCC for preparing the structural design treated it as a single work. Later, the work was split up into 7 works of similar nature for which seven sanctions were obtained from MHA in order to avoid approval of higher authorities i.e. Group of Ministers\*.

NSG did not offer their comments for works at S. No 1 to 3 CRPF (for work at S. No. 4 above) stated (June 2015) that it sanctions project as per requirement/urgency at various/different locations keeping in view the availability of funds. Accordingly, sanctions are being accorded by the competent authority/MHA for individual building separately. NBCC stated that CRPF conveyed the sanction of estimates in phases and accordingly agreement with CRPF has been executed for each sanctioned work separately. Reply was not acceptable as Group of Ministers sanctioned the work as single project but MHA accorded the approval by splitting the works in order to avoid the approval of higher authority.

\*\* Group of Ministers: ₹ 150 crore and above but less than ₹ 300 crore

BSF (for work at S. No. 5 above) stated (June 2015) that the sanction for each component was accorded keeping in view of priority as well as availability of fund. There is no splitting as each work was issued separate sanction. The reply was not acceptable as the eight works constituted a single project and splitting up of the single work contravened Rule 130 of GFR.

#### 4.2.2 Delay in sanction of Administrative Approval and Expenditure Sanction

There was no norm/time limit fixed by CAPFs/MHA for according sanction of AA/ES. Our scrutiny of 710 works revealed that on an average, five months were taken for according sanction of AA/ES by CAPFs/MHA from the date of submission of PE by the executing agencies. Audit observed that out of 710 works, in 197 cases (26.76 per cent) involving total sanctioned amount of ₹ 1392.82 crore, CAPFs/MHA took more than five months (up to 76 months) for according sanction of AA/ES (**Annex-1.3**). The reasons for taking such a long time in according approval of AA/ES were not available in records. The force-wise position of time taken is as follows :

**Table-4.8: Details of works with delay in sanction of AA & ES**

Name of the Force	Total number of cases	Number of cases where time taken was more than average i.e. five month	Amount involved for more than average cases (₹ in crore)
AR	132	12	173.77
BSF	155	42	158.01
CISF	61	14	140.11
CRPF	171	75	626.58
ITBP	102	17	69.57
NSG	14	3	51.88
SSB	75	34	172.90
<b>Total</b>	<b>710</b>	<b>197</b>	<b>1392.82</b>

Though there is no specified time period within which the AA & ES is to be accorded after the submission of the PE, undue delay in the grant of AA & ES can lead to an increase in cost of Detailed Estimate, rendering AA & ES irrelevant. This can be rectified by the forces as it comes under the direct influence of forces.

CPWD and CAPFs accepted the observation stating that the delay was mainly attributed to time lag in receipt of expenditure sanction from MHA/DG office and some mechanism is being devised to minimize the time taken.



### RECOMMENDATION:

CAPFs may fix a time frame for accord of AA & ES of construction activities, as this process is within their complete control, devoid of any external influence.



### 4.2.3 Non-obtaining of revised expenditure sanction

Para 2.3.5, 2.4.2 & 2.16.2 of CPWD Works Manual and para 71 of CPWD Code stipulate that in case the actual expenditure exceeds 10 *per cent* of AA & ES, a revised AA & ES must be obtained from the authority competent to approve the cost so enhanced.

Audit noticed that in respect of 33 works, although total expenditure on the works exceeded 10 *per cent* of the AA & ES ranging from 10.16 to 114.07 *per cent*, no revised administrative approval was obtained from the competent authorities (**Annex-4.4**).

CAPFs other than BSF and AR in their reply stated that total expenditure/release of funds is within 10 *per cent* of the amount of AA & ES, while BSF stated that matter is being taken up with CPWD. Reply was not acceptable as it was noticed that the figures of final expenditure were higher by more than 10 *per cent* of the amount of AA & ES.

An illustrative case study was given below:

#### Case Study 4.9 :

Audit examination revealed that for construction of Airbase with provision of helicopter hanger for BSF at Srinagar, revised expenditure sanction for an amount of ₹ 689.21 lakh was received by the client department in June 2012. Against the revised sanction, an expenditure of ₹ 873.48 lakh was incurred by the executing agency on the work without any sanction having been received by either the client or CPWD. Thus, an expenditure of ₹ 183.67 lakh in excess of the sanctioned amount was incurred.

CPWD stated that revised estimates for AA & ES were being submitted to the client department. The reply was not acceptable in view of the fact that the funds were not available in the project and no approval was obtained before incurring expenditure over the sanctioned cost.

### 4.3 TENDERING PROCESS

Audit examination revealed lacunae in tendering process by the executing agency such as delay in award of work, absence of transparency in tendering, incompleteness of contractual documents, inappropriate selection of bidders etc. as explained in the succeeding paras :

#### 4.3.1 Delay in tendering process

CPWD generally takes a time limit of three to six months (from the date of AA/ES) for award of work. This included (i) time for pre-tendering work such as preparation and obtaining of necessary sanction of design, drawing and detailed estimate etc. and (ii) time for tendering such as inviting tender, negotiation and award of work etc. Since there was no criterion available in this regard, audit adopted the upper limit of six months as generally accepted practice.

Audit noticed that out of 710 works checked, 681 works were awarded to the contractors, and for remaining 29 works<sup>6</sup> even tenders were not invited after sanction of AA & ES as of December 2014. Audit examination of 681 works revealed that in 240 works (33.8 per cent) involving ₹ 1161.10 crore, there was delay in initiating tendering process ranging from seven to 90 months from the date of sanction of AA/ES (**Annex-1.3**). The agency-wise break up is given in following table:

**Table 4.9: Details of works with delay in tendering process**

(₹ in crore)

Name of the PWOs	No. of works delay beyond 6 month to awarding the contract	Amount involved
CPWD	187	912.61
DEPARTMENTAL	26	9.99
DMRC	1	3.06
EPIL	5	102.36
HPL	1	1.55
NBCC	8	77.76
NPCCCL	7	39.76
UPJN	5	14.01
<b>Total</b>	<b>240</b>	<b>1161.10</b>

The delay in award of works was attributed to the delayed receipt of decision/approval for the changes in LOP, delayed preparation of drawing and design/detailed estimate, non-availability of funds and re-tendering etc. CPWD and PWOs did not offer their comments.

An interesting case of delay in award of work by CPWD is given below as case study:

<sup>6</sup> 29 works are shown in bold text in Annexure-1.3

### Case Study 4.10

The work Construction of Border Out Post (BOP) of BSF at Nalka, Rajasthan, was awarded by CPWD in the 10<sup>th</sup> round of tendering after a delay of two and half years. In the 1<sup>st</sup> round (August 2011), lowest bid was ₹ 35.17 lakh but it was cancelled with a view to obtain rate within justification since estimated cost was ₹ 20.57 lakh. From second to fifth round, there was either no response or just one quote received, due to which it was cancelled. In the sixth round, (February 2012) rates were within justification, but tender could not be decided by CPWD within bid validity period i.e. in 90 days as CPWD took more time in preparing justification and analysis of rates. 7<sup>th</sup> to 9<sup>th</sup> rounds did not elicit any response. Work was finally awarded in 10<sup>th</sup> call with tendered cost of ₹ 51.32 lakh, resulting in cost escalation of ₹ 16.15 lakh (46 % of original offer).

BSF in its reply (January 2015) stated that that 1<sup>st</sup> call was cancelled in hope that in 2<sup>nd</sup> call, rate may be obtained within justification and in 6<sup>th</sup> call it was cancelled as newly enrolled Junior Engineer took more time in preparation of analysis of rates and justification.

### 4.3.2 Irregular award of work

Para 15.1(8) of CPWD Works Manual provides that for any work not covered under the purview of composite tendering, tenders for electrical and building works (including sanitary and water supply works) must be invited concurrently, or at an appropriate stage when they are required to be commenced. As per Para 15.1 of CPWD Works Manual, 2007 read with Section 95 of CPWD code, availability of clear site is desirable before approval of Notice Inviting Tender (NIT). Further, as per Clause-15 of instruction to the Executive Engineer for e-tendering, the Executive Engineer should invite tenders only after taking over the possession of land and when the site is free for construction.

Audit examination revealed that in 10 construction works with an expenditure sanction of ₹ 65.60 crore, various irregularities in the tendering process were found like improper justification of rates, receipt/sale of tender after due date etc. (**Annex-4.5**). A glaring example is as follows:

For construction of 102 quarters for AR at Chieswema, Nagaland with estimated cost of ₹ 11.28 crore, NPCCL in April 2008 invited tender through advertisement in the two news papers. Due to non-receipt of bids in the first four bidding during April-July 2008, NPCCL had to invite tender for the 5<sup>th</sup> time in August 2008. In response to the tendering for the 5<sup>th</sup> time held in August 2008, six local contractors (all registered with NPCCL) quoted exorbitant rate compared to the rate specified in the sanctioned estimate (₹ 11.28 crore). The lowest offer of ₹ 14.80 crore received in 5<sup>th</sup> bidding was found justified based on the revised cost index effective from July 2008. Due to this, the work was awarded at a cost which was ₹ 3.52 crore more than the original sanctioned estimate/amount put to tender.

Audit examination revealed that as per the newspaper advertisements, the eligibility criteria and other details of the tender were available on two web-sites ([www.assamrifles.com](http://www.assamrifles.com) and [www.npccindia.com](http://www.npccindia.com)). Audit found that the web-site '[www.npccindia.com](http://www.npccindia.com)' belonged to a private agency (located in Bahamas) and other web-site '[www.assamrifles.com](http://www.assamrifles.com)' did not exist at all. After inviting tender for the third time (June 2008), NPCCL gave the correct web-site address '[www.npcc.gov.in](http://www.npcc.gov.in)' in place of '[www.npccindia.com](http://www.npccindia.com)' by issuing corrigendum, but they did not change the non-existent web-site address '[www.assamrifles.com](http://www.assamrifles.com)'. As such contractors (other than local contractors) were unable to participate in tendering.

It was seen that NPCCL in no other case invited tender with wrong web-address. Offers from local contractors were received only in the fifth time tendering held in August 2008 i.e. the very first tendering after the revision of cost index in July 2008 and the higher rates quoted by the contractors were found justified by NPCCL/AR on the basis of revised cost index of July 2008.

#### 4.4 DETAILED ESTIMATE (DE) AND TECHNICAL SANCTION (TS)

Rule 129(1) (iv) of General Financial Rules (GFR) stipulates that no work shall commence or liability incurred unless an estimate containing the detailed specifications and quantities of various items have been prepared on the basis leading to deviations in the quantity of work executed, the Detailed Estimates (DE) should be supported with detailed drawing/design. Moreover, before preparation of DE, drawing and design, the executing agency needs to obtain assurance from the client department about the availability of site free from all encumbrances.

Further, the executing agency has to accord Technical Sanction (TS) to ensure that the design, drawings and specification as shown in the estimate are technically sound. As per Section 2.5.1 (a) of CPWD manual, DE supported by drawings and design are required to be prepared for TS. Further, for execution of any extra item not provided in the TS, approval of the competent authority needs to be obtained beforehand to ensure its appropriateness.

Audit examination found cases of incomplete in the preparation of DE leading to huge deviation in quantities during execution of works, absence of TS, execution of extra items without sanction, technical flaws etc. as detailed below:

##### 4.4.1 Absence of Detailed Estimates and Technical Sanction

None of the PWOs other than CPWD to whom MHA/CAPF entrusted their building works prepared the DE properly as required in the GFR. Audit found that the PWOs just mentioned the number of various items to be executed without their quantity and the rate. MHA rectified this deficiency and included provision for the same in the revised format of MoU issued in May 2011. Despite MHA's instruction, the deficiency continued to persist.

Audit noted that in 107 works of CAPFs executed through PWOs i.e. NPCCL, HPL, EPIL and NBCC, involving cost of ₹ 381.37 crore (**Annex-4.6**), DEs were not prepared. Audit noticed that NBCC in its works prepared the bill of quantity (items and cost of works to be executed) without detailed drawings and designs and the cost of items was kept within the limit of expenditure sanction. This resulted in significant variations between the estimated quantity of works and their cost of actual execution. Similarly, in 10 cases (**Annex-4.7**), CPWD prepared DEs which were not supported by detailed drawings and design. Consequently, the works were held up by 39 days to 222 days.

It was also noticed that AR paid the portion of departmental charges (DC) of ₹ 38.58 lakh meant for the preparation of DE in 33 completed works, while the DEs were in fact not prepared. Besides, there would be a liability of ₹ 56.76 lakh in respect of 74 on-going works of AR and BSF on this account.

Assam Rifles, BSF and Chief Engineer, NEZ-I, CPWD accepted the audit observation stating that endeavor would be made to recover these charges and care would be taken to prepare realistic detailed estimates.

As none of the PWOs in 107 works prepared DE, audit had no evidence to substantiate whether the technical sanctions were accorded in these 107 works involving ₹ 381.37 crore (**Annex-4.6**).

Assam Rifles admitted the observation by attributing this to executing agencies. The Executing agencies viz. NPCCL, EPIL and HPL, on their part agreed to comply with the audit observation in future. NBCC stated that tender scrutiny committee was empowered to accord technical sanction. The reply was not acceptable as tender scrutiny committee was meant for scrutiny of tenders whereas technical sanction was accorded by a designated competent authority.

#### **4.4.2 Execution of extra item without technical sanction**

Audit found that in 12 works (**Annex 4.8**), CPWD in contravention of section 23.2.3 of CPWD Manual 2007 did not obtain prior concurrence of Technical Sanctioning authority before execution of extra items amounting to ₹ 2.13 crore.

CRPF stated that CPWD/PWO prepare detailed estimates later and technical sanctions are obtained by them from their competent authorities. Reply was not acceptable as in the above cases, extra items were executed without technical sanction from the competent authority.

#### **4.4.3 No revision of Technical Sanction**

As per para 2.5.2 of CPWD Works Manual, the technical sanction can be exceeded by up to 10 *per cent* beyond which revised technical sanction shall be necessary.

In seven works (**Annex-4.9**) executed by CPWD, it was noticed that although the expenditure incurred was beyond 10 *per cent* of the technical sanction, the revised technical sanctions were not obtained from competent authority in contravention of the aforesaid provisions. CPWD in its reply accepted the audit observation.

#### 4.4.4 Preparation of flawed design

Preparation of flawed design for construction of building was noticed in CRPF work at Khatkhati, Assam which has been explained as case study below:

##### Case Study 4.11:

CRPF entrusted the work of construction of 180 barracks (three in number each having three stories) at Khatkhati, Assam to NPCCL. The work was awarded by NPCCL to a contractor in December 2006 at a tendered amount of ₹ 8.59 crore. However, the contractor suspended the work from November 2007 due to local insurgency problem, flood, heavy rain etc. and subsequently the contract was terminated by NPCCL in March 2008. The contractor had executed works valuing ₹ 92.87 lakh and the CRPF had paid ₹ 76.05 lakh to NPCCL against the total claim of NPCCL of ₹ 99.38 lakh including seven *per cent* departmental charges. Based on the drawings initially prepared by NPCCL and obtaining confirmation from CPWD about the suitability of the works done by the first contractor, the balance work was entrusted to CPWD at the sanctioned cost of ₹ 22.98 crore in November 2009. The balance work was awarded (November 2010) to a second contractor. However, CPWD in April 2011 informed CRPF that the foundation was structurally unsafe for taking up the load of three stories as it was constructed by NPCCL without necessary provision to withstand earthquake effect. It was finally decided to restrict the construction of the buildings to two stories and one three storied building had to be taken up additionally. The proposal was approved by MHA in July 2011. The second contractor refused (October 2012) to construct the additional block and the same was awarded in April 2013 to a third contractor.

It was observed in audit that

- Due to abandonment of the work, MHA had instructed the force to levy and recover compensation amounting to ₹ 86.35 lakh from NPCCL. Neither ₹ 86.35 lakh had been recovered nor the amount of ₹ 28.45 lakh already recovered by NPCCL from the first contractor had been refunded to the CRPF.
- Due to technical flaws in design and drawings prepared by NPCCL and certification of its soundness by CPWD without prior assessment, the work done by the first contractor up to plinth level was subsequently found structurally unsafe because of which CRPF would have to incur extra expenditure of ₹ 2.09 crore (Approx.)<sup>7</sup>
- Despite incurring an expenditure of ₹ 10.94 crore till October 2014, the work could not be completed even after expiry of over six years from the scheduled date of completion (March 2008) due to technical flaws.

CRPF in its reply (June 2015) stated that 98 *per cent* work of barrack at Khatkhati had been completed and case for recovery of LD for ₹ 86.35 lakh was under correspondence with NPCCL.

<sup>7</sup> Awarded cost of three Buildings including plinth (initially G+2) = ₹ 15.21 crore. So, awarded cost of one building ₹ 15.21/3 i.e. ₹ 5.07 crore. Awarded cost of additional building including plinth (G+2) = ₹ 7.16 crore. Therefore extra expenditure due to construction of additional building = ₹ 2.09 crore (₹ 7.16 - ₹ 5.07) crore

The audit findings mentioned above covered preparatory work before the start of actual execution. The actual work of construction is done by the PWOs by contracting it out to third parties and monitoring it closely for quality and timely completion within the budget.

It can be seen that at all stages there were deficiencies, while delays were the foremost reason for problems, as summarised below:

PE	AA & ES	DE and TS	Tendering	Execution
<ul style="list-style-type: none"> <li>• Inadequate PE</li> <li>• Incorrect PE</li> <li>• Approval not obtained from local authorities</li> <li>• Delays in sanction</li> </ul>	<ul style="list-style-type: none"> <li>• Splitting up of work</li> <li>• Delays in sanction</li> <li>• Non obtaining of sanction</li> </ul>	<ul style="list-style-type: none"> <li>• Inadequate DE</li> <li>• Absences of DE</li> <li>• Flawed DE</li> <li>• Delays in sanction</li> </ul>	<ul style="list-style-type: none"> <li>• Delays in tendering</li> <li>• Irregular award of works</li> </ul>	<ul style="list-style-type: none"> <li>• Delays in commencement and coordination</li> <li>• Delay in completion</li> <li>• Deviations/extra/substituted items</li> <li>• Cost and time overrun</li> </ul>

## 4.5 EXECUTION OF WORK

Audit noted various deficiencies in execution of works viz. non-compliance with rules and contractual provisions, incomplete/faulty contractual provisions, delay in completion of works as well as payments of escalation on this account, non-maintenance/improper maintenance of documents etc. The details are explained in the succeeding paras:

### 4.5.1 Delay in commencement of work

- Examination of SSB work of construction of infrastructure at Yelki District-Hingoli (Maharashtra), sanctioned at a cost of ₹ 53.69 crore (September 2013) and awarded to NBCC for execution revealed that it was yet to take off due to non selection of site as of December 2014.

SSB in its reply (June 2015) accepted the observation and stated that handing over of site was never a problem and it was wrongly quoted by the NBCC. It stated that there was delay in tendering of work by NBCC which ultimately was awarded in November 2014 and work started in January 2015.

- Three works of AR for ₹ 5.31 crore were awarded during October 2013 to December 2013 at a total tendered value of ₹ 4.62 crore (**Annex-4.10**). These works were yet to take off as of November 2014 even though 67 to 80 per cent of the time specified for its completion had already elapsed. Further study in audit revealed that these works were awarded to those contractors who could not

complete the works awarded to them on earlier occasions. Thus, AR did not verify the past performance of contractors before award of work.

Assam Rifles (April 2015) admitted the audit findings by stating that they would direct the executing agency either to pursue the contractor to mobilise the resources or to go for retendering after cancelling the contract.

#### 4.5.2 Deviated items

Deviation means deviation in quantities of items, i.e. where there is increase or decrease in the quantities of items of work in the agreement. Clause 12.2 and 12.3 of 'General Conditions of Contract' provides deviation limit beyond which the rate should be worked out by adopting the market rate for material and labour. The limits as specified in schedule-F of the contract is 30 *per cent* in case of building work and 100 *per cent* in case of foundation work. As per Para 24.1.2 (2) of CPWD works manual, deviation in quantities of individual item beyond the limit of + 10 *per cent* but within deviation limit as specified under clause 12 of the contract, will not require prior approval of technical sanction authority but total deviation (including initial + 10 *per cent*) shall be sanctioned by officers as per delegation of powers.

It was noticed that in respect of 241 works (**Annex-1.3**), there were deviations in items beyond the permissible limit ranging from -100 *per cent* to +10469 *per cent* which indicated that quantities of items of work mentioned in the detailed estimates were not realistically estimated, based on field survey and site conditions. Total amount of such items was ₹ 82.88 crore. The deviations occurred due to site condition, structural requirement as per drawings and change in scope by client.

CPWD stated that deviation was within financial limit. The reply was not convincing because the limit of deviation in quantity was not adhered to.

NBCC stated that in the detailed estimate, certain items were provisioned in anticipation of being carried out in the work to avoid execution of extra items beyond BOQ and avoiding subsequent approval of competent authority and execution was done as per actual requirement. Reply was not acceptable as detailed estimate should be prepared as per actual requirement. CAPFs in their reply accepted the observation and stated that the deviations beyond permissible limits were due to changes in the site requirement.

Executing agencies with number of works in which deviations were found along with force wise details of items deviated were given in following table:



Table 4.12: Details of works where deviation was beyond the permissible limit

(₹ in crore)

Executing Agency	Total no. of works in which deviation found	Percentage of works against total number of works	Amount of deviation	No. of items where deviation was more than 30% and 100 % against the BOQ (both above or below)	Range of deviation (in per cent)	
					Minimum (-)	Maximum (+)
CPWD	187	43	64.42	1 to 320	(-) 100	(+)10469
DEPTT.	20	22	1.17	1 to 64	(-) 100	(+) 2650
EPIL	2	12	7.27	4 to 18	(-) 100	832
HPL	3	18	0.53	2 to 6	(-) 100	(+) 976
NBCC	7	14	2.47	2 to 181	(-) 100	(+)352
NPCC	22	25	7.02	1 to 18	(-) 100	(+) 3900
<b>Total</b>	<b>241</b>		<b>82.88</b>			

It was evident from above that in the works executed by CPWD and CAPFs departmentally, there were more deviations in items used in their works than in the works executed by PWOs.

Some illustrative case studies are given below:

#### Case Study 4.12

MHA in October 2007 sanctioned ₹ 3.25 crore for construction of boundary wall for a CRPF Group Centre at Agartala. Owing to huge deviation from DE ranging from -100 per cent to +761 per cent, CPWD in December 2008 declared the incomplete work as closed after incurring an expenditure of ₹ 3.07 crore as funds were also exhausted. Audit found that out of 87 items identified in the agreement, 70 were not at all executed. CPWD, in December 2008, submitted a revised estimate for ₹ 7.54 crore and CAPF/MHA took 1½ years to accord (July 2010) sanction of ₹ 6.54 crore. The balance work was awarded in April 2011 and was completed in May 2013. Had the first estimate been properly prepared, it could have saved ₹ 48.46 lakh. Moreover, the work conceived in October 2007 took 5¾ years to complete.

Assam Rifles stated that deviation occurred due to site / user requirement. The reply was not tenable as DE was not supported with requisite drawings.

#### Case Study 4.13

Audit found that in two works (**Annex-4.11**) of CISF and SSB, the contractors were paid at higher rate (market rate) than the agreement rate by CPWD, owing to the deviation in excess of the prescribed limit as specified in the agreement, leading to extra expenditure of ₹ 43.53 lakh against these works. PWOs did not offer their comments.

### 4.5.3 Extra items

As per section 24.2.3 (1) and 24.2.3(3) of CPWD Work Manual, no extra item should be executed or approved without the prior concurrence of its necessity by the authority that accorded the technical sanction. Further, no work of addition/alteration which involves structural changes in the residential buildings, or alters the aesthetics of the external facade, shall be carried out except with the approval of concerned architect. As per Para 24.1.2 (4) of CPWD works manual 2012, in case of deviations occurring in the quantities of substituted/extra items/deviation in quantity of any item already sanctioned, revised sanction should be taken from the competent authority.

Audit noticed that 305 works having extra items (ranging from 1 to 186 items) for ₹ 30.16 crore were executed by the executing agencies (**Annex-1.3**). Executing agencies with no. of works in which extra items were used along with force wise details of extra items are given in following table:

**Table 4.13: Details of works where extra items used**

(₹ in crore)				
Executing Agency	No. of works where extra items used by executing agencies	Force-wise no. of works where extra items used	Amount of extra items	No. of extra items
<b>CPWD</b>	235 (53%)	BSF-44, CISF-32, NSG-07 CRPF-90, ITBP-36, SSB-26 <b>Total-235</b>	23.62	1 to 186
<b>DEPTT.</b>	42 (45%)	AR-1,BSF-24, NSG-3, ITBP-5, SSB-9 <b>Total-42</b>	0.97	1 to 30
<b>DMRC</b>	01 (100%)	CISF-01	0.22	22
<b>EPIL</b>	01 (6%)	AR-1	0.03	1
<b>HPL</b>	02 (12%)	AR-2	0.28	1
<b>NBCC</b>	11 (22%)	BSF-1, CISF-3, CRPF7 <b>Total-11</b>	2.54	2 to 52
<b>NPCCCL</b>	13 (15%)	AR-13	2.50	1 to 26
<b>TOTAL</b>	<b>305</b>	<b>305</b>	<b>30.16</b>	

It was evident from above that more extra items were used in the works executed by CPWD and CAPFs departmentally than in the works executed by PWOs. Reasons for execution of extra items were mainly relating to site conditions, sometimes items were not included in the agreement or because of structural requirement. CAPFs accepted (June 2015) the observation by stating that extra items were executed as per site requirement and demand of client department which were approved later by the competent authority.

Paras 3.6 and 4.7 of CPWD Works Manual 2012 provide that the scope of work should not be altered without written permission of the client.

Audit noticed that in 20 works (**Annex-4.12**) where extra items amounting to ₹ 159.33 lakh were used, executing agency had altered the scope of work but required permission was not obtained from client/competent authority.

Chief Engineer (CZ) CPWD, Bhopal stated (February 2015) that in principal approval could not be obtained prior to execution of items due to urgent nature as well as interconnected items, however as per verbal approval, extra items were executed and these items have been sanctioned by the competent authority later. The reply was not tenable because execution of extra items of work without technical sanction was contrary to provision stated *ibid*. Further progress of remaining works has not been received (March 2015).

#### 4.5.4 Substituted items

132 works (**Annex-1.3**) involving substituted items (ranging from 1 to 24 items) for ₹ 10.80 crore, were executed by the executing agencies. Reasons for execution with substituted items were mainly site requirements, non-availability of items in the market and as per client requirement etc. Executing agencies with no. of works in which substituted items used along with force wise details of substituted items are given in following table:

**Table 4.14: Details of works where substituted items used**

(₹ in crore)

Executing Agency	No. of works where substituted items used by executing agencies	Force-wise no. of works where substituted items used	Amount of substituted items	No. of substituted items
CPWD	109 (25%)	BSF-18, CISF-19, CRPF-51, ITBP-13, NSG-2, SSB-6	10.19	1 to 24
DEPTT.	17 (18%)	AR-1, BSF-11, ITBP-2, SSB-3	0.34	1 to 16
NPCCL	1 (1%)	AR-1	0.03	1
NBCC	5 (10%)	CRPF-5	0.24	2 to 9
<b>Total</b>	<b>132</b>	<b>132</b>	<b>10.80</b>	

In the works executed by CPWD and CAPFs departmentally, more substituted items were used than in the works executed by PWOs.

CAPFs accepted (June 2015) the observation by stating that substituted items were executed as per site requirement and demand of client department which were approved later by the competent authority.

Chief Engineer (CZ) CPWD, Bhopal stated (February 2015) that in principal approval could not be obtained prior to execution of items due to urgent nature as well as interconnected items, however as per verbal approval, substituted items were executed and these items have been sanctioned by the competent authority later. The reply was not acceptable as execution of substituted items of work without technical sanction was contrary to provision stated *ibid*. Further progress of remaining works had not been received (March 2015).

## 4.5.5 Cost & time overrun

### 4.5.5.1 Cost overrun due to delayed execution

Audit noticed that in 129 completed works (**Annex-4.13**) with initial sanctioned cost of ₹ 335.88 crore, which was revised to ₹ 398.90 crore resulted in cost escalation of ₹ 63.02 crore. Audit also noticed that in 32 works (**Annex-4.14**) which were in progress and incomplete, with initial sanctioned cost of ₹ 130.41 crore, cost was revised to ₹ 215.44 crore which resulted in cost overrun of ₹ 85.03 crore up to December 2014. Thus, there was total cost overrun of ₹ 148.05 crore in total 161 works up to December 2014. The reasons for such revision of AA & ES and cost overrun was escalation of labour and materials cost, execution of extra/deviated/substituted items, change in scope of work etc.

Audit also found savings in 189 completed works with initial sanctioned cost of ₹ 766.83 crore, but actual expenditure incurred on these works were ₹ 477.75 crore, which resulted in saving of ₹ 289.08 crore (**Annex-4.13**). The savings were due to wrong calculation of plinth area by the department, modification of drawing, increase in plinth area, revision of estimate and site conditions etc. Though there were delays in completion of works executed by all the executing agencies, there were savings after completion of work. It was indicative of the fact that either estimates prepared by the executing agencies were inflated or items taken in the Bill of Quantities (BOQ) were not executed which resulted in huge savings. MHA and CAPFs also approved the overstated estimates without proper verifications, which indicate poor financial control in budgeting and expenditure sanctions.

CAPFs in their reply admitted the observations and stated that PWO authorities have been requested to avoid any escalation due to delay in execution. Some interesting cases of cost overrun are discussed below:

Table 4.15: Details of interesting cases of cost overrun

(₹ in lakh)

S. No	Name of work	Executing Agency	AA&ES amount	Revised AA&ES/ Actual expenditure	Cost overrun	Audit observation
1.	C/o Boundary Wall at Group Centre, CRPF, Neemuch (MP)	CPWD	302.91 September 2007	496.78 August 2010	193.87	Due to delay of 22 months in start of construction work by CPWD, the cost of construction material abnormally increased, which resulted in cost overrun of the work by ₹ 193.87 lakh.
2.	C/o Recreation hall, CRPF at Coimbatore	CPWD	95.42 January 2008  Tendered cost ₹ 92.22	129.35 November 2010	37.13	The estimate was prepared in December 2007 but due to delay of nearly 20 months in approving the drawings, resulted in increase in cost by ₹ 37.13 lakh due to cost index difference.
3.	C/o Family Quarters for CRPF, at Hyderabad	CPWD	1323.0 September 2004	1948.0 March 2009/ 1668.00 March 2010	345.0	Delay in handing over of site and lack of follow-up resulted in inordinate delay of more than 3 years in execution of work, leading to a cost overrun of ₹345 lakh.
4.	C/o Compound wall for 400 acres of land acquired for Central Training College-II, CRPF, Coimbatore	CPWD	95.88 September 1995	127.08/ January 2005/209.44  December 2009	82.36	Awarded for ₹ 95.88 lakh in January 1996. Boundary wall on 378 acres of land at a cost of ₹112.56 lakh was completed in June 1999. Remaining 22 acres of land was under dispute with forest department and it was identified by State Government in July 1997. C/o boundary wall on 20 acres was taken up after a lapse of seven years in January 2005 at the estimated cost of ₹ 31.20 lakh but could not be executed again as the stones were again found

S. No	Name of work	Executing Agency	AA&ES amount	Revised AA&ES/ Actual expenditure	Cost overrun	Audit observation
						missing. After re-survey in 2008, the work was commenced in January 2009 and completed (December 2009) at a cost of ₹ 96.88 lakh. It resulted in cost overrun of ₹82.36 lakh.
5.	Replacement of Overhead Electrical line by underground cables at CRPF Campus Pallipuram, Thiruvananthapuram.	CPWD	69.54 December 2005	93.78 June 2010/ 94.49 December 2012 but final bill not paid so far	24.24	There was delay of more than three years in getting A.A. & E.S sanctioned and more than one year in tendering the work.
6.	Renovation of Electrical Installation in 192 Quarters at Group Centre, CRPF, Pallipuram Thiruvananthapuram	CPWD	57.87 March 2004	95.66 May 2009 (sanction awaited)/ 84.87 for remaining 72 quarters October 2014 (sanction awaited)/Actual expd. 61.52 work not completed	122.66	The delay of 18 months in according A.A&E.S, 12 months in awarding the work and 49 months in completion of works and failure by CRPF in timely release of funds resulted in non-completion of work even after 10 years. This also resulted in cost escalation of more than 100 per cent. Beside these quarters could not be put to use so far.

#### 4.5.5.2 Unfruitful expenditure of ₹ 7.52 crore

During execution of works, instances were noticed where expenditure incurred/payments made to contractor were unfruitful. Details of some such interesting cases are discussed below:

Table 4.16: Details of works where expenditure was unfruitful

(₹ in lakh)

S. No	Name of work	Executing agency	Stipulated/ actual date of completion	Actual expenditure	Audit observation
1	C/o storage tank and development of site for water supply schemes for SSB TC Sarahan (H.P).	CPWD	March 2010/ December 2014	124.00	Work was completed after a delay of 5 years but the water supply scheme was non-functional resulting in unfruitful expenditure of ₹ 124 lakh.
2	C/o 1450 mt. Boundary Wall with gates and sentry posts for BSF Campus, 80 bn. BSF, Khemkaran under SHQ, BSF, Ferozpur	CPWD	27-11-12 /4-12-13	128.00	CPWD completed the construction of only 1266 metre out of total 1450 metre boundary wall after a delay of one year. The purpose of boundary wall to provide complete security was not achieved due to incomplete execution of the work which resulted in unfruitful expenditure of ₹128 lakh.
3	C/o Boundary Wall at Group Centre, CRPF, Neemuch (MP)	CPWD	August 2009/March 2010	500.17	Due to rain (August 2010 and August 2011) 485 metre of boundary wall collapsed before the possession being taken over by CRPF from CPWD. Final payment was made to the contractors without getting it re-built. Purpose for which the expenditure of ₹500.17 lakh was incurred remained unachieved and unfruitful. CRPF accepted the observation and stated that revised sanction was accorded but collapsed boundary wall had not been completed/re-constructed by CPWD authorities yet through the contractor as it collapsed before handing over and was under defect liability period.
		<b>Total</b>		<b>752.17</b>	

#### 4.5.6 Delay in completion of work

Audit noticed that out of total 710 works, 29 works were not awarded to the contractors up to December 2014. Out of balance 681 awarded works, in 405 works (59 per cent) involving ₹ 1723.25 crore, there was delay of 14 months on an average (ranging from 1 month to 66 months) in completion of the works after the stipulated period (**Annex-4.13**). However, in 150 cases (37.4 per cent) involving ₹ 847.52 crore, the delay was more than 14 months. Agency wise breakup of the delay in execution is given in the following table:

**Table 4.17: Details of delay in completion of works**

(₹ in crore)

Executing Agency	Number of works delayed	No. of Force-wise delayed works	Range of delay (in months)	Amount involved for cases of delay	Number of works where delay was above average	Amount involved for above average cases of delay
<b>CPWD</b>	254 (58%)	BSF-45, CISF-36 CRPF-96, ITBP-36 SSB-33, NSG-8 <b>Total-254</b>	1 to 66	932.20	82 (19%)	362.58
<b>Deptt.</b>	61 (66%)	BSF-28, ITBP-12 NSG-05, SSB-13 AR-03 <b>Total-61</b>	1 to 31	22.13	16 (17%)	4.98
<b>EPIL</b>	5 (31%)	AR-05	1 to 51	31.28	4 (25%)	24.53
<b>HPL</b>	5 (29%)	AR-05	1 to 52	26.87	05 (29%)	26.87
<b>NBCC</b>	32 (64%)	BSF-13, CRPF-12 ITBP-01, CISF-04 SSB-2, <b>Total-32</b>	1 to 64	473.23	13 (26%)	273.48
<b>NPCCCL</b>	44 (51%)	AR-44	1 to 45	213.10	27 (31%)	143.57
<b>UPJN</b>	2 (33%)	AR-02	1 to 22	8.45	2 (33%)	8.45
<b>DMRC</b>	1(100%)	CISF-01	29	3.06	1 (100%)	3.06
<b>JKPCC</b>	1 (100%)	BSF-01	4	12.93	-	-
<b>Total</b>	<b>405</b>	<b>405</b>		<b>1723.25</b>	<b>150</b>	<b>847.52</b>

It is evident that the works executed by CPWD and CAPFs departmentally were delayed more than the works executed by other PWOs. The delay in execution was mainly attributed to delay in handing over/non finalization of the site, non-availability of approachable site, change/non-preparation of drawing and building plan, change in Layout Plan, heavy rain, frequent bundhs, remoteness of site, labour crises, ban on migrant labour from other states and failure of contractors etc. CAPFs further added that they had granted extension of time after verifying the facts brought out by the PWOs. SSB and BSF also stated that where there was delay on the part of executing agency, they were penalised as per the contractual clause. In most of the cases, hindrances were



justified hence extension was granted as per CPWD Manual Clause. The reply was not acceptable as the delay occurred either on the part of CAPFs or PWOs.

Some interesting cases with respect to delays are:

**Table 4.18: Details of some interesting cases of delay in works**

(₹ in lakh)

Sl. No.	Name of work	Executing agency	Stipulated date of completion	Actual expenditure	Audit observation
	C/o Sewage Treatment Plant (STP) at ITBP campus, Patiala	CPWD	29-1-2010/ incomplete as on December 2014	26.61	The work which was to be completed in January 2010 remained incomplete till date of audit (November 2014). The expenditure incurred on the STP was wasteful as the target of providing sanitation services in the ITBP Campus was not achieved.
	C/o residential and non-residential buildings at GC CRPF, Bhubaneswar	CPWD	August 2012/ Incomplete	39.00	Even after 2 years of award of work, it was not completed due to non-allotment of funds by CRPF to CPWD.

#### 4.5.7 Taking over of incomplete work /delay in handing over of Works

After completion of the construction work, CAPFs were required to appoint a Board of Officers to check the construction thoroughly as per specifications and requirements before taking over the site. However, following instances were noticed in handing/taking over of sites, where assets were takeover by CAPFs before works were complete in all respects.

**Table 4.19: Details of taken over of assets by CAPFs before completion of work**

(₹ in crore)

Name of works	Executing agency	Sanctioned amount	Audit observation
Five works for AR (i) C/o qtrs, allied services and development works for AR at Keithalmanbi. (ii) C/o Magazine Building and development Work at Kakching, Manipur	NPCCCL	33.88	"Side beams" on the road had to be provided to 3.96 Km of bituminous road in Manipur were taken over by AR without the same being constructed by NPCCCL.  3.20 Km of GI Pipe line for water supply running along the road was done without providing the required anti-corrosive paint coat. It was handed over by NPCCCL to AR. AR admitted the audit

Name of works	Executing agency	Sanctioned amount	Audit observation
(iii) C/o Single JCOs accm., single men barrack, Admn. Block, Officers Mess with development work for AR			observations.
(iv) C/o Single Men Barrack with approach Road for AR			
(v) C/o Single JCOs accm., single men barrack, Admn. Block Officers Mess with development work for AR at Kakching, Manipur.			
C/o Barrack at Navi Mumbai for CRPF	CPWD	0.60	Work which was stopped due to court cases and legal issues, was taken over by the Force during October 2009, but could not be put to intended use and resulted in unfruitful expenditure of ₹ 57.38 lakh besides creating additional liability of ₹ 60.02 lakh to rectify the defects.
Providing internal roads, culverts etc for BSF at Karahalli, Bengaluru Rural district	CPWD	0.20	Road work in two stretches for a length of about 200 meters was yet to be executed since this stretch required construction of culverts. Though the original PE provided for construction and allied works of 10 culverts at a cost of ₹ 20.30 lakh, the said item was not included in the tender. Despite the incomplete road work for 200 meters, CPWD issued completion certificate to the agency. CPWD stated in reply that the items for the work of construction of culverts were left over in the revised PE due to oversight. A separate estimate was got sanctioned now.
C/o barracks of CRPF in Greater Noida, U.P.	NBCC	14.48	NBCC handed over the construction of barracks of CRPF in Greater Noida without carrying out the work of basic amenities like electricity and sewage. These basic amenities were temporarily arranged by NBCC at an expenditure of ₹4.22 lakh.
C/o Family quarters for CRPF, Pune	CPWD	92.99	Part of work was completed by NBCC in February 2010 and handed over to CRPF between November 2012 and March 2013 after a lapse of 33-37 months and remaining works involving an expenditure of ₹ 25.72 crore, completed in December 2012 with a delay of 14

Name of works	Executing agency	Sanctioned amount	Audit observation
			months were not handed over to the client department till December 2014. CRPF in its reply accepted the observation and stated that the defects pointed out were not being rectified by PWO promptly.

Two interesting cases are discussed as case studies below:

#### Case Study 4.14 :

##### Unfruitful expenditure of ₹ 2.96 crore

The work of family quarters for CRPF, Chandrayanagutta, Hyderabad with AA&ES of ₹ 9.90 crore was awarded to a contractor in April, 2006 at a tendered cost of ₹ 7.39 crore with stipulated date of completion as April, 2007. The work was rescinded in January 2007 due to slow progress and was awarded to second contractor at tendered cost of ₹ 8.41 crore. The contractor completed 128 quarters valuing ₹ 8.22 crore and handed over these to CRPF by September 2013, leaving the balance work of 64 quarters incomplete at various stages as on December 2014. Later, the scope of the original work was increased from 180 to 192 quarters and the estimate was revised to ₹ 14.90 crore (September, 2013). This estimate



included an amount of ₹ 68.37 lakh on completed portion of the work which was not deleted while inviting tenders afresh. As on date (June 2015), the balance 64 quarters (192-128) were not completed and the expenditure of ₹ 2.96 crore remained unfruitful as CRPF staff couldn't move into their quarters even after a lapse of 6 years of estimated date of completion (April 2007). Besides, the Department was tied up in a requirement of more than ₹ 5 crore for completion of the pending works and an arbitration case filed by the first contractor.

CRPF accepted (June 2015) the observation and stated that extra fund is being demanded by the first contractor for same project and is under scrutiny.

**Case Study 4.15:****Taken over of Quarters by AR without rectification of defects**

AR awarded the work of construction of 12 Type-III quarters and 48 Type-II quarters at Jorhat, Assam to EPIL. EPIL divided the same in 4 packages and awarded one package of 16 Type-II quarters to a contractor in May 2006. These quarters were constructed at a cost of ₹ 91.58 lakh and handed over to the AR in May 2011. Audit noted that several defects i.e. absence of roof treatment in any of the quarters, poor quality of plaster, doors and windows and substandard fly proofing, were detected (March 2012) by the AR after 09 months from the date of handing over. As a result, 2 quarters remained unoccupied (October 2014). Thus, due to absence of proper monitoring and quality checking by the force, the above defects were not noticed, 02 quarters could not be occupied yet and defects in other quarters were still to be attended.

Assam Rifles in their reply could not offer any explanation for these irregularities.

**4.6 OTHER IRREGULARITIES****4.6.1 Commencement of work without work order/agreement**

As per Ministry of Finance's instruction under para 1.2.2 (vii) of Manual on Policies and Procedure for Procurement of Works (CVC instruction in 2002), no work shall commence until a work order has been issued. Audit found that NPCCL in 27 works (**Annex-4.15**) of AR and NBCC in 9 works (**Annex-4.16**) of BSF did not adhere to this instruction as they concluded agreement with the respective contractors only after 51 days to 567 days of commencement of the work. Moreover, in 11 works (**Annex-4.15**) payment of ₹ 8.89 crore was made before entering into a formal agreement.

PWOs did not offer their comments, however, Assam Rifles (April 2015) admitted the observation by stating that they would ensure compliance by incorporating suitable provisions in their future MoUs with PWOs.

**4.6.2 Execution of unauthorized temporary work of ₹ 39.04 lakh**

Audit Scrutiny of records of NBCC revealed that the construction activities of BSF at Mathura included expenditure of ₹19.60 lakh on construction of one temporary barrack and of ₹ 19.44 lakh incurred on one temporary toilet block. These works were not part of the original work and had not been sanctioned by the competent authority. Thus, expenditure of ₹ 39.04 lakh was irregular.

BSF accepted (June 2015) the observation and stated that the temporary structures at BSF campus Mathura were constructed by NBCC as per the requirement of BSF in order to keep their office and stores in safe custody. Reply is not acceptable as these works were neither part of the original work nor sanctioned by the competent authority.

### 4.6.3 Site not acquired for work

For construction of barrack at Jammu for BSF, administrative approval and expenditure sanction of ₹ 4.62 crore for the work was conveyed by the client department to CPWD in February 2014. Accordingly CPWD took up the matter with the BSF authorities for providing site for construction. The client department intimated that site for the work was not available and would take the department two more years in identifying the site. Thus, the BSF authorities without site identification forwarded the proposal to the MHA for expenditure sanction by showing that land was available, resulting in non construction of barracks.

BSF accepted (June 2015) the observation and stated that the sanction was issued with the presumption that land will be finalized by the time of award of work. But land was not finalized and alternate piece of land at Samba was being provided for construction of the barrack where work had started now.

### 4.6.4 Non-maintenance of Documents

Hindrance Register is maintained to keep a record of all the hindrances during the execution of work. Audit examination of records pertaining to works executed in North Eastern region revealed that out of 56 completed packages of AR in five works involving tendered amount of ₹ 36.13 crore , PWOs (NPCCL, EPIL, UPJN and HPL) did not maintain hindrance register. In 9 projects, the labour license of the contractor was not available on record. In many cases, fortnightly report was not available on record. As per CVC guidelines, payments to the contractor are to be made through e-payment. However, from the records furnished to audit, it was seen that the guidelines were not followed in many projects. Similarly, other documents like measurement books, inspection register, contractor ledger etc. were not maintained properly by the executing agencies in many cases.

PWOs did not offer their comments, however, Assam Rifles admitted the audit findings by stating that they had directed the PWOs to maintain Hindrance Register at the work site.

## 4.7 CONCLUSION

The process of construction works ranges from selection of executing agency after necessary approvals to handing/taking over of site after construction. Audit found deficiencies and delays at every step. Selection of executing agency for construction works was not based on any criteria and competition amongst the executing agencies was missing. Proper assessment and planning for the requirement was not done by the client as well as executing agencies which resulted in unfruitful expenditure/excess/avoidable payments as evident from the preceding paragraphs. Instances of works being awarded without preparation of proper detailed estimates, violation of GFR and MHA orders were noticed. Audit also noticed that approval of local authorities for lay-out plans and

drawings was not obtained even after the completion of works in many cases. It was noticed in many instances that instead of preparing one estimate for the project, splitting up of work was resorted to avoid A/A and E/S from higher authorities.

Audit found that CAPFs/PWOs failed to finalise preliminary drawings with complete scope and specification in reasonable time which increased the estimated cost of works and delayed execution. Estimates prepared by PWOs were higher, leading to overpayments. PWOs did not prepare realistic and firm detailed estimates supported by detailed plans, drawings and specifications which led to huge deviations at the time of execution. Large scale deviations in bill of quantities (BOQ) were noticed beyond the permissible limit ranging from (-) 100 per cent to (+) 10469 per cent which indicates that quantities of items of work mentioned in the detailed estimates were not realistic.

The main factors which contributed to the deficiencies in construction work can be grouped in to four clusters, as shown below.

**Drag forces at work**

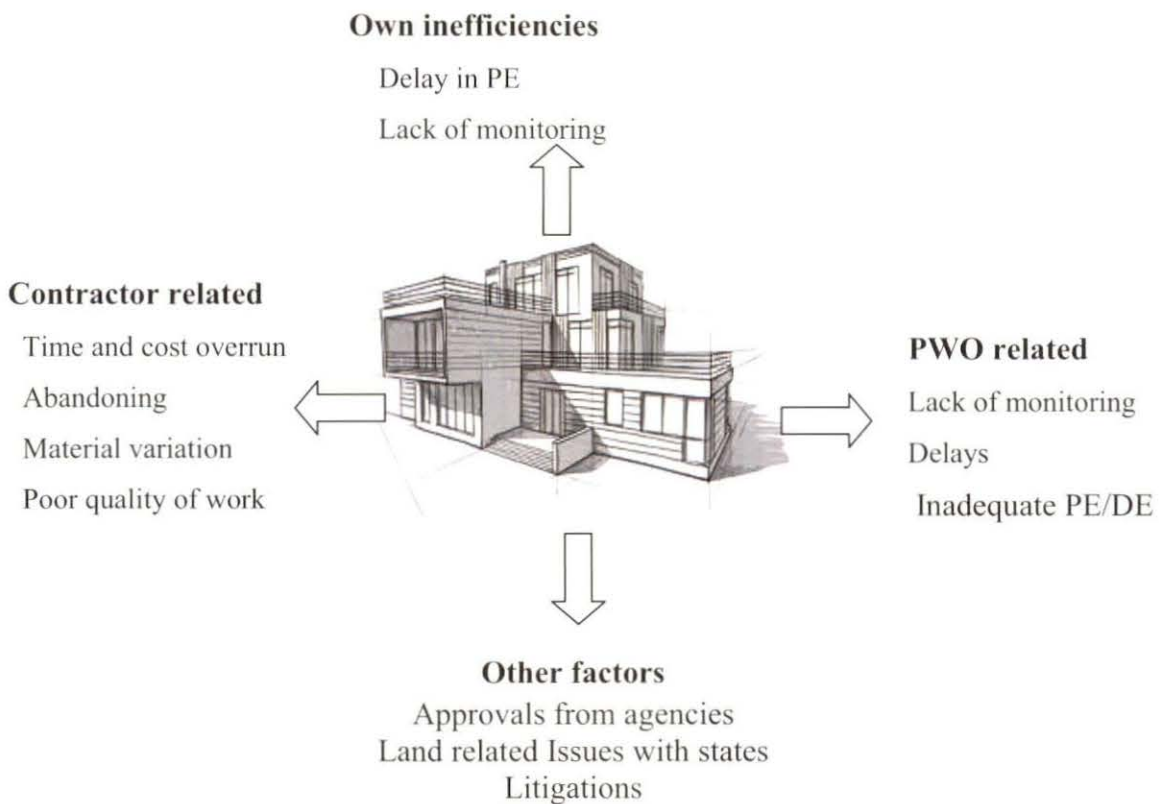

Audit also noticed execution of large number of extra and substituted items during construction without taking requisite approvals of the client department. Undue benefits to contractors by substituting costlier items with cheaper items or execution of extra items citing site or structural requirements could not be ruled out. While monitoring, each milestone was not meticulously analyzed by the agencies involved. PWOs repeatedly failed to ensure documentation of requisite data for delay analysis which could benefit the

contractor. Audit also found that incomplete works without basic amenities viz. electrification, sewage work etc, were taken over by the CAPFs, due to which asset created remained unutilized for long time.

Thus, it can be seen that a sense of engagement between MHA/CAPFs/PWOs was missing while creating high value capital assets. MHA/CAPFs and executing agencies may take remedial measures to make necessary corrections in the system so as to ensure that the works are started and completed on time and intended benefits reached the end users on time.

## CHAPTER – V

## Executing Agencies- A Comparative Analysis

An analysis of issues involved in the planning and execution of works by the executing agencies viz. CPWD, Public Works Organizations and CAPFs with their own engineering wing was carried out on the basis of following criteria:

- Preparation and submission of Preliminary Estimates
- Not obtaining requisite approvals from local authorities
- Irregularities/delay in tendering process
- Deviation in items/Extra items/Substituted items
- Delay in completion of work
- Cost overrun in completed works due to delayed execution
- Savings in completed works due to overstated estimates

For comparing the working of executing agencies, audit selected 710 works each amounting more than ₹10 lakh executed by CPWD, PWOs and Departmental works by CAPFs which have engineering wing during the period 2008-09 to 2013-14 as depicted below :

**Chart-5.1: Executing agency-wise selected works**

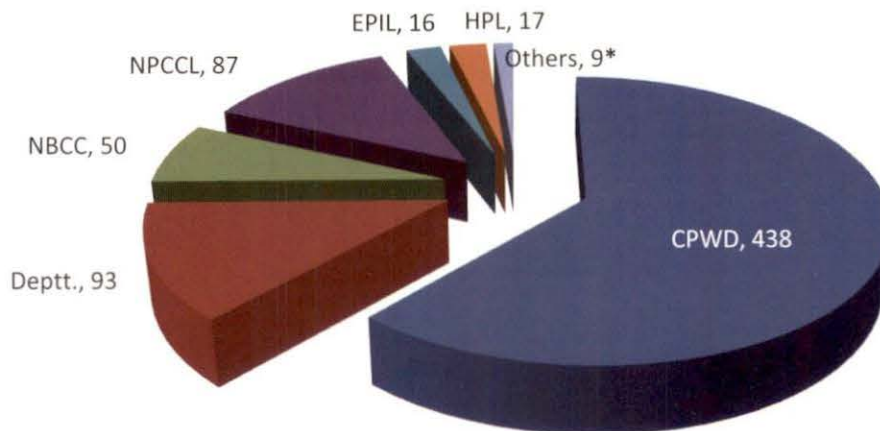

Others, 9\*: DMRC-1, JKPCC-1, ECB-1, UPJN-6

Audit collected the data during audit examination for above parameters and critically analyzed the data, the conclusions of which are elucidated in succeeding paras :



## 5.1 PREPARATION AND SUBMISSION OF PRELIMINARY ESTIMATES (PEs) BY EXECUTING AGENCIES TO CAPFs

Though no standard time frame for preparation and submission of PEs by the executing agencies to CAPFs exists, audit worked out five months as the average time taken by the executing agencies in submission of PEs from all the works audited. Thus, the works which took more than five months in preparation of PE are depicted below:

**Chart 5.2: Percentage of works where PEs delayed by more than average time of five months**

Legend: Executing agency (average delay in months), *per cent* of cases

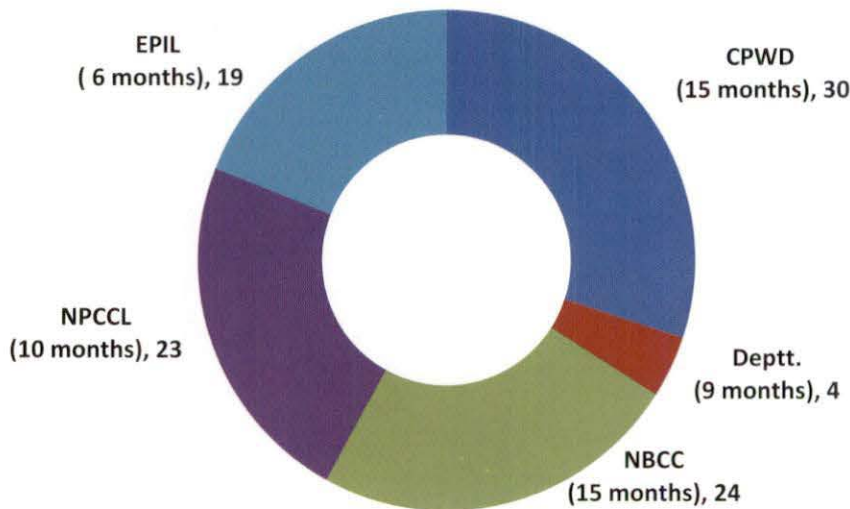

CPWD and NBCC took on an average of 15 months in their 30 and 24 *per cent* works, while NPCCL and EPIL took ten and six months in their 23 and 19 *per cent* works respectively in submitting PEs to CAPFs. Though CAPFs having their own engineering wings, have to prepare PEs themselves, four *per cent* of the total departmental works also submitted delayed PEs on an average of nine months. Delay in the preparation and submission of PEs invariably pushed the deadlines further, right at the beginning of the project itself.

## 5.2 DELAY IN TENDERING PROCESS

Audit noticed that there were more delays in award of work in CPWD, departmental works and PWOs. No criterion was fixed by executing agencies for themselves in so far as efficiency was concerned. After allowing a reasonable timeframe (upper limit) of six months for award of work, delays were calculated from the date of approval of AA&ES to award of work. Out of 710 works checked, 681 works were awarded to the contractors while for the remaining 29 works<sup>1</sup> no tenders were invited after sanction of AA&ES as of December 2014. Audit examination of 681 works further revealed that in 240 works (33.8

<sup>1</sup> 29 works are shown in bold text in Annex-1.3

per cent) involving ₹ 1161.10 crore, there were delays beyond six months in awarding the contracts, ranging from 7 to 90 months from the date of sanction of AA/ES as depicted in the chart here.

The delay in award of works was attributed by the executing agencies to the delayed receipt of decision/approval for the changes, delayed preparation of drawing and designs, detailed estimate, non-availability of funds and re-tendering etc.

It is evident that CPWD took more time as compared to PWOs which included NBCC (8 works), NPCCL (7 works), EPIL (5 works), UPJN (5 works), HPL and DMRC one work each and departmental works. Delay in award of works caused delay in their completion which ultimately resulted in cost overruns.

**Chart 5.3: No of works where there was more than six months delay in tendering process**

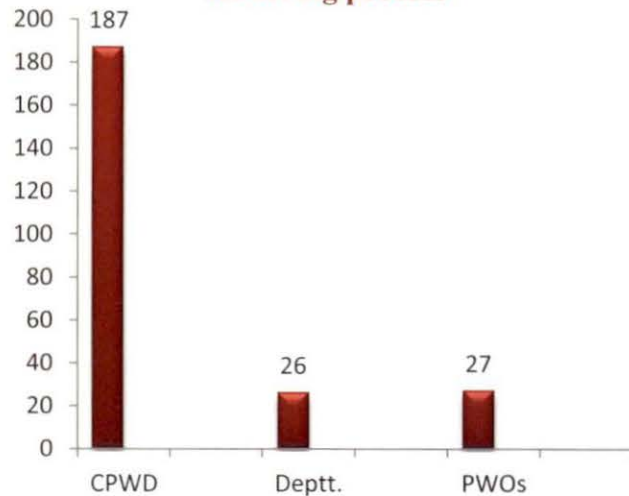

### 5.3 REQUISITE APPROVALS FROM LOCAL AUTHORITIES NOT TAKEN BEFORE ISSUE OF NIT BY THE EXECUTING AGENCIES

Audit examination of records revealed that all executing agencies i.e. CPWD, PWOs and CAPFs did not take approvals from the local authorities before issue of NIT in almost all works where approval was necessary as evident from Table 5.1.

**Table 5.1: Details of approvals taken from the local authorities by the executing agencies**

Executing agency	Total works selected	Total works for which approvals required before issue of NIT	Approvals not taken before issue of NIT
CPWD	438	170	168 (99%)
Deptt.	93	31	26 (84%)
NBCC	50	31	19 (61%)
NPCCL	87	87	87 (100%)
EPIL	16	16	16 (100%)
HPL	17	17	17 (100%)
OTHERS*	9	8	8 (100%)
<b>TOTAL</b>	<b>710</b>	<b>360</b>	<b>341</b>

\*DMRC-1, JKPC-1, ECB-1, UPJN-6

Only NBCC in 39 per cent and CAPFs in 16 per cent departmental works took approvals from the local authorities before issue of NIT of works. This clearly shows that the executing agencies did not follow the prescribed procedures and despite substantial time taken in initial planning did not take requisite approvals.

#### 5.4 DEVIATION IN ITEMS/EXTRA ITEMS/SUBSTITUTED ITEMS

Audit noticed large scale deviations in the quantities of items executed in the works by the executing agencies as depicted below :

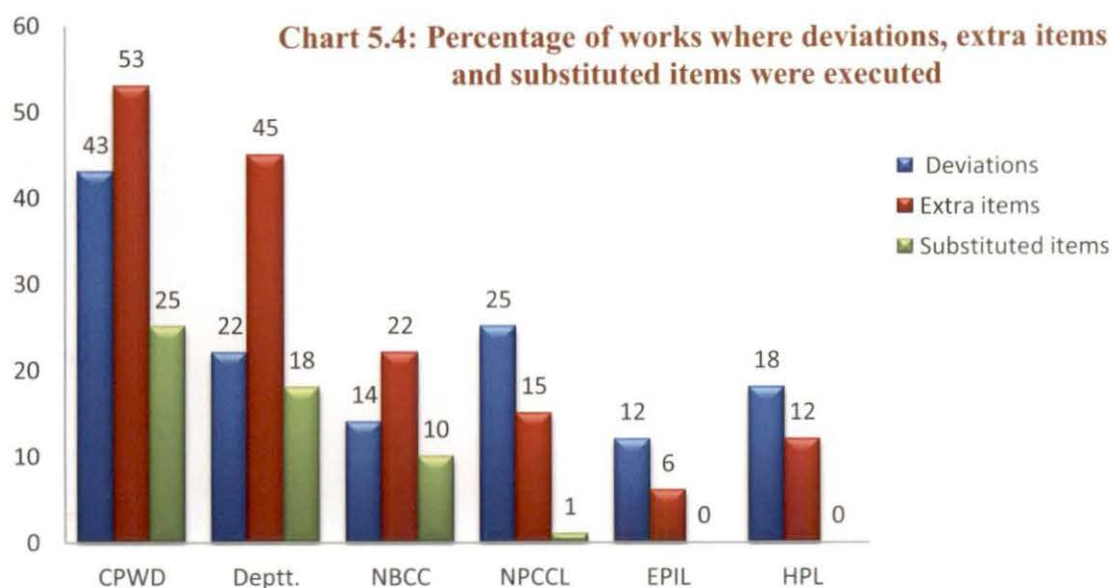

Though the permissible deviation in work is 100 per cent in foundation works and 30 per cent in building works, none of the executing agencies could stick to the stipulation. Audit noticed that works of CPWD had more deviations followed by departmental works and works executed by NPCCL. The executing agencies stated that the deviations in works were due to site condition, structural requirement as per drawings and change in scope by client. CPWD being the biggest and oldest executing agency still resorted to many change in original plans. In all cases, total deviations resulted in extra cost of ₹ 82.88 crore. It is indicative of the fact that quantities of items of work mentioned in the detailed estimates were not realistic based on detailed field survey and as per the site conditions.

Agencies also executed large number of extra and substituted items in the works. Audit noticed that in 53 per cent works executed by CPWD and 45 per cent departmental works, extra items costing ₹ 23.62 crore and ₹ 0.97 crore respectively were used. In case of PWOs works ranging between 6 and 22 per cent, extra items costing ₹ 5.35 crore were used. Thus, extra items were used more in the works executed by CPWD and CAPFs having their own engineering wing. Executing agencies stated that execution of extra items was attributable to requirement of site, item not included in agreement, structural requirement as per drawings and items executed to make the building functional. It

confirms the fact that these were not considered while preparing DE. Similarly, audit noticed that CPWD (25 per cent) and CAPFs in departmental works (18 per cent) used substituted items costing ₹ 10.19 crore and ₹ 0.34 crore respectively. In case of PWOs, only NBCC used substituted items in 10 per cent works costing ₹ 0.24 crore. Execution of extra and substituted items by the executing agencies not only resulted in deviations from the plans but also led to extra financial burden due to increase in cost of the works.

### 5.5 OVERALL DELAY IN COMPLETION OF WORK BY THE EXECUTING AGENCIES:

Audit noticed that out of 710 works checked, 405 works were delayed by the standards set in individual contracts. This ranged from one month (less than one month not considered) to 66 months. Audit bifurcated the delays in to all cases of missing the deadline and chronic delays of more than 14 months. (14 months being the average delay in 405 works) This calculation was done only for display purpose, as shown below in the chart:

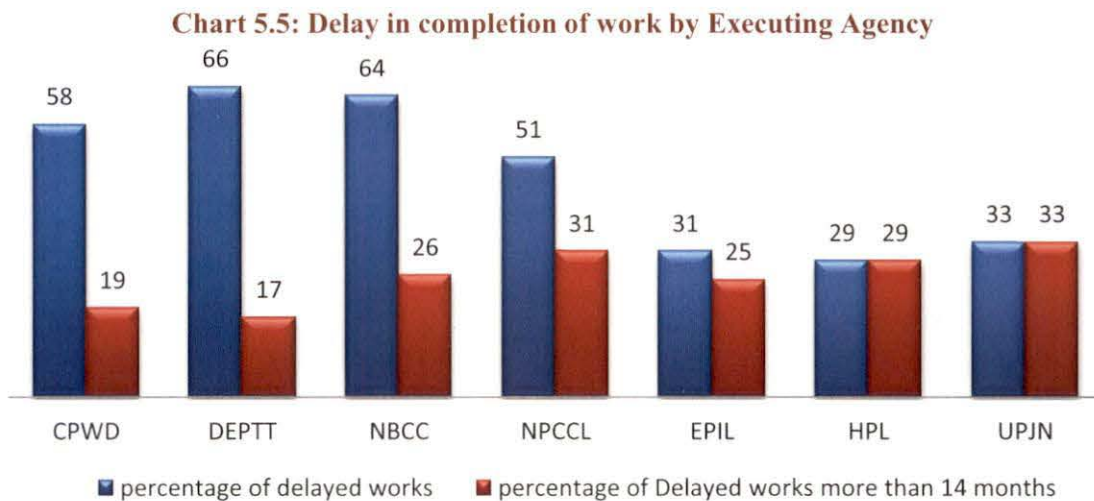

It was noticed that in 58 per cent works executed by CPWD, there were delays in completion of work ranging between 1 and 66 months. Works done departmentally, where the CAPFs directly deal with the contractor also showed delays. It comes into view that all agencies were almost equally placed when it came to delay in work completion. The executing agencies stated that the delays were mainly due to delay in handing over/non finalization of the site, change/non-preparation of drawing and building plan etc. Delay in completion of work resulted in cost overrun due to rising cost index and caused avoidable financial burden to the exchequer.

### 5.6 COST OVERRUN DUE TO DELAYED EXECUTION

Audit noticed cost escalations due to delays in completion of work by the executing agencies as depicted below:

Chart 5.6: Cost overrun in completed works of PWOs

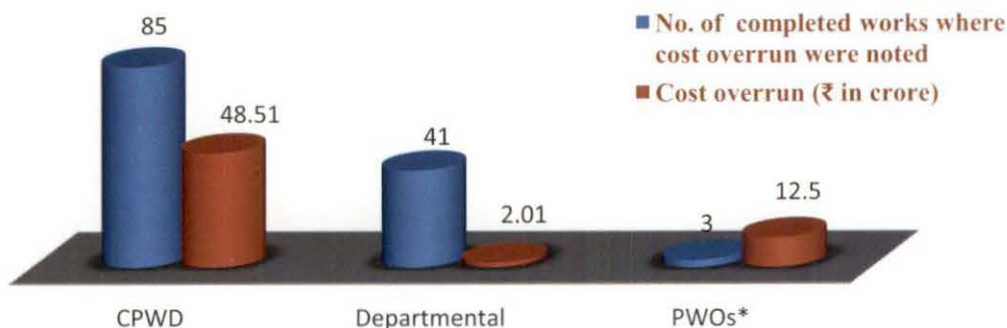

PWOs\* included NBCC (2 works, ₹ 12.0 crore) and DMRC (1 work, ₹ 0.49 crore)

It was noticed that in 129 completed works, there were cost overruns amounting to ₹ 63.02 crore. Cost overrun was found more in CPWD and Departmental works, which could be linked to delays, deviation and extra items. Audit noticed large scale deviations and execution of extra items in the works executed by CPWD and departmental works. The delays were mainly attributed to delay in handing over/non finalization of the site, change/non-preparation of drawing and building plan, change in Layout Plan, heavy rain, remoteness of site (in north eastern states), frequent bundhs, labour crises, ban on migrant labour from other states (eastern states) etc.

## 5.7 SAVINGS AFTER COMPLETION OF WORKS

In a number of works audit noticed savings by the executing agencies after completion as depicted below:

Chart 5.7: Completed works with savings

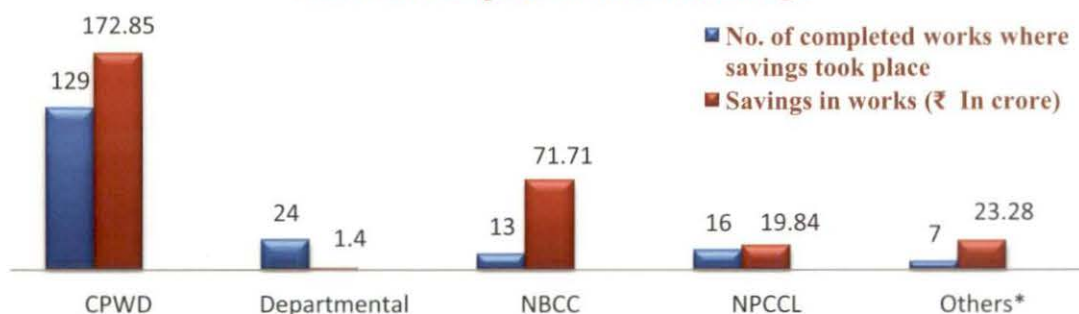

Others\* includes EPIL (5 works, ₹ 6.02 crore), HPL (1 work ₹ 5.58 crore) and JKPCCL (1 work, ₹ 11.68 crore)

There were large savings amounting to ₹ 289.08 crore in 189 completed works executed by all the executing agencies. Huge savings were noticed in CPWD in 129 works amounting to ₹ 172.85 crore, NBCC in 13 works of ₹ 71.71 crore and NPCCL in 16 works of ₹ 19.84 crore.

While comparing cost escalation and savings, it was noted that these two factors were mutually exclusive, i.e. occurring in different works. It was stated that the savings were due to wrong calculation of plinth area by the department, modification of drawing, increase in plinth area, revision of estimates, site conditions etc. It clearly indicates that either the estimates prepared and submitted by the executing agencies were on the higher side or some items were not executed in the works as planned. MHA and CAPFs also approved the overstated estimates without proper analysis and verifications, which indicated poor financial control in budgeting and expenditure sanctions.

## 5.8 CASE STUDY

An illustrative example in which an executing agency erred at several stages is detailed below:

The work of construction of four Nos. 240 men barracks of CRPF at Group Centre, Greater Noida was awarded to NBCC in May 2006. NBCC submitted an estimate of ₹ 14.48 crore for barracks in May 2006. The AA & ES was accorded by MHA in January 2007 with the stipulated period of completion as 18 months from the date of AA&ES. The work was actually completed in January 2010 and taken over from NBCC by CRPF without electricity, water sewage and development works. Even up to June 2015, necessary approvals from local authorities had not been obtained and associated development works were not completed. Audit noticed that NBCC erred during execution of work at many stages as explained below in diagram:

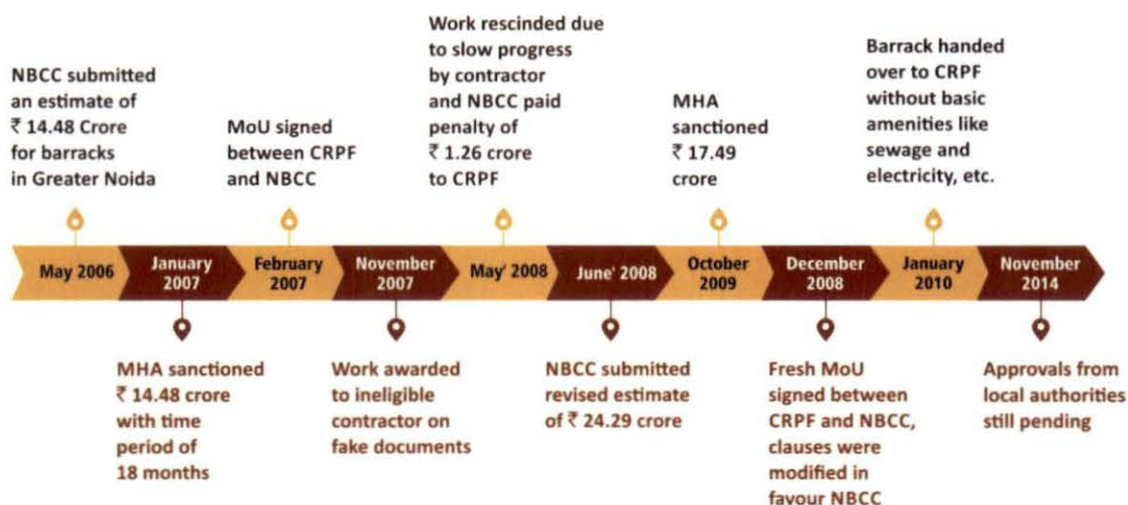

CRPF in its reply (June 2015) accepted the observation and stated that work was delayed due to un-avoidable circumstances viz delay in obtaining the revised sanction from MHA/unprecedented price hike in the market, delay in getting approval of lay out plan(LOP) and building plan from the local authorities. Penalty/LD had already been recovered from NBCC to the tune of ₹ 1.27 crore for slow progress of work by the

contractor. It further stated that NBCC had been directed several times to get approval of the local authorities, but because of administrative problems at every stage, a reasonable delay had occurred in obtaining the approval from local authorities. At present, approval of LOP/Environmental Clearance have been obtained from local authorities and approval of building plan is in progress with Greater Noida Authority. Since, the construction of barracks were completed in January 2010 and sanction for development & Bulk Services (Civil) were received on 03/12/2009 but as per MoU completion period for completion of work of development & Bulk Services (civil) was 24 months. In view of taking proper utility of these constructed barracks for Jawans, expenditure of ₹ 4.22 lakh have been expended towards development & Bulk Services (Civil) to save the damage & better life of constructed structure.

Thus, it was evident from above that the work sanctioned in January 2007 for ₹ 14.48 crore which was due to be completed by June 2008 was finally completed in January 2010 with a final expenditure of ₹ 17.49 crore which resulted in not only time overrun of 18 months but also cost overrun of ₹ 3.01 crore. Further, barracks handed over to CRPF by NBCC were without basic amenities like electricity and sewage system etc. due to which jawans had to manage with temporary arrangements.

### 5.9 CONCLUSION

From a comparative analysis of executing agencies based on various parameters to assess the construction activities, it was seen that the agencies were at par when compared on different parameter of efficiencies. Delays in preparation of preliminary estimate and in tendering process were seen in all PWOs, while CPWD showed maximum aberrations as it was the largest PWO and was executing the maximum number of works. Construction works undertaken by CPWD showed the maximum cases of cost escalation and also the highest savings, indicating a less than satisfactory financial planning of works. More deviations, extra items and substituted items were noticed in CPWD followed by departmental works. One area where CAPFs can improve without external interference is the works undertaken departmentally.

#### RECOMMENDATION:

CAPFs may set standards for construction works done departmentally, as it was not better in comparison to other PWOs in terms of planning and execution of works.

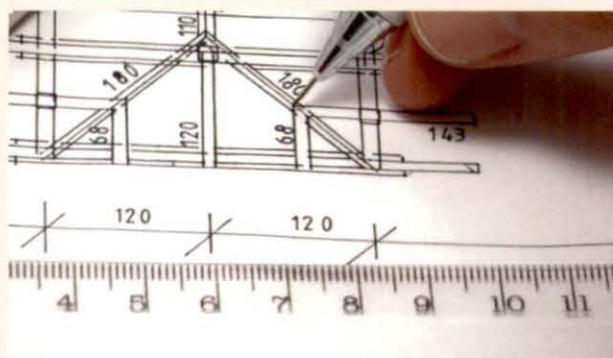

## CHAPTER – VI

## Quality Assurance, Monitoring, Utilisation & Maintenance of Assets

### 6.1 QUALITY ASSURANCE MEASURES BY EXECUTING AGENCIES

To ensure quality of work, various measures have been laid down in CPWD Works Manual like (i) testing of material, (ii) monitoring of brand and quantity, (iii) periodical inspections by higher authorities and quality assurance wing, and (iv) third party inspection. PWOs were required to follow the above quality assurance measures. Audit examination revealed lapses in quality assurance measures as detailed below.

#### 6.1.1 No inspection by Quality Assurance Wing

Audit found that there was no practice of inspection by quality assurance wing of the CPWD as none of the works executed by CPWD had been inspected by the quality assurance teams. Further, audit noticed that PWOs viz. NBCC, EPIL etc. also did not have any quality assurance wings. In the absence of this, the assurance given by PWO about the building was questionable. Jettisoning of this important ingredient towards quality assurance was questionable.

#### 6.1.2 Lapses in Quality Testing

The quality testing lapses viz. non-testing of material and water, testing of brand other than that was actually used, utilization of unapproved brand etc. were noticed in audit during examination of 18 works executed by CPWD/PWOs as detailed below:

**Table-6.1: Lapses in quality testing**

(₹ in crore)

Name of work	Executing agency	Tendered cost	Audit observation
Construction of Residential quarters at 38 Bn. Tawang, Arunachal Pradesh of SSB	CPWD	3.53	Steel used in these works was not tested. Moreover, the brand of cement used (Vinay Cement) was not the approved brand of cement for the works.
Construction of Residential quarters at 34 Bn. at Dirang, Arunachal Pradesh for SSB and C/o GO's mess and suits at Itanagar, Arunachal Pradesh for ITBP	CPWD	2.49	Brand of cement tested (Vinay Cement) was different from the brands (Star Cement and Birla Gold) used in the works.



Name of work	Executing agency	Tendered cost	Audit observation
Construction of GO's mess and single officer accommodation at, Teju, Arunachal Pradesh for ITBP	CPWD	1.51	Portland Pozzolana Cement which was not prescribed for the work was utilised. Out of four brands of such cement used in this work, testing of only one brand was carried out.
Construction of type-V quarters, allied services and development works and c/o 1 block of 4 SM barrack, 1 JCO Mess and one 20 bedded Hospital of AR at Haflong, Assam	NPCCL	6.46	Cement and sand used in the works were not tested.
Construction of 8 SM Barracks of AR at Khonsa, Arunachal Pradesh	EPIL	6.92	Unapproved brands of steel like 'Graystone Ispat and Tiger brands' were used. However, the sample that was actually checked by the EPIL was found to be a brand (Biscon) different from that was used in the work.
Augmentation of water supply scheme of AR at Jairampur, Arunachal Pradesh	UPJN	3.52	Local brand of steel and cement was used, that too without any testing
C/o Regimental School with allied services and development works at Lokra, Assam	NPCCL	0.82	Materials were tested much after the commencement of the work.

Some instances of poor quality works executed by the executing agencies are depicted below:

Inspection of Family Accommodation for ITBP at Dehradun conducted by joint inspection team comprising the members of audit team and CPWD personnel revealed that the plaster was broken at several places and there were cracks in walls on ground floor in Type-I quarters as evident from the photographs.



Audit observed that the aforesaid work was completed in April 2009, and these defects were brought to the notice of CPWD in May 2010. However, no action has taken by CPWD to rectify these defects.

During site visit audit noticed cracks in the road constructed by CPWD in February 2010 during execution of work of approach road to parade ground at CRPF, GC, Kadarapur, Gurgaon, which indicates deficient quality of the work.



Leakages seen at residential quarters at GC, CRPF, Hyderabad. CPWD replied that notices were issued to the contractor for attending the leakage on walls. However, fact remains that the CPWD had not monitored the quality of the work properly.



Audit noticed poor quality of work executed by NBCC in the work of barracks for CISF jawans at SSG, Greater Noida as shown here.



### 6.1.3 Use of water without testing in construction works

As per the CVC Guidelines of August 2008, water should be tested at regular intervals to ensure proper quality of concrete work. Audit noted that in none of the 40 works of AR involving tendered amount of ₹ 202.38 crore (**Annex-6.1**) water used for the work was tested.

### 6.1.4 Non-maintenance of Quality Assurance records

As per the CVC Guidelines of August 2008, lot wise manufacturer's test certificates of steel and cement were required to be obtained and kept in record to ensure quality assurance. It was found that in respect of 59 works of AR, CRPF and ITBP involving sanctioned cost/tendered amount of ₹ 373.90 crore (**Annex-6.1**) manufacturer's test certificates were not obtained.

Moreover, audit also noticed that in 44 works of AR involving ₹ 222.66 crore (**Annex-6.1**), no theoretical statement of consumption was worked out and compared with the quantity of steel, cement and paint actually used in those works.

AR admitted the observation by stating that they had directed all PWOs to set up quality assurance wing of their own apart from making a list of quality control test to be done in works and independent agency/institution near work site to carry out testing of samples.

### 6.1.5 Third party inspection

In 98 per cent works of CPWD and 100 per cent works of PWOs (except NBCC with 84 per cent works) and departmental works of CAPFs as depicted below in **Chart 6.1**, there was no provision of third party inspection and quality assurance in the MoU/Agreement between CPWD/PWOs and the client CAPFs was found. It was evident that mechanism of third party monitoring was altogether absent in most of the works of CAPFs.

**Chart 6.1: Percentage works where no provision for third party inspection made**

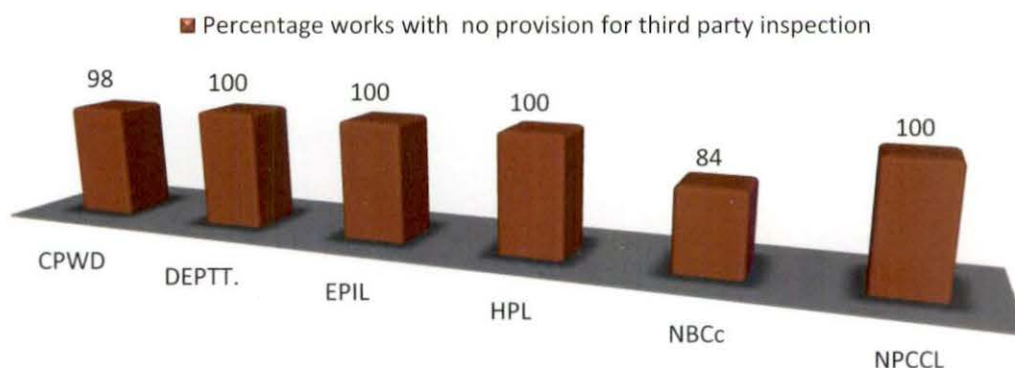

However, audit noticed that 44 PEs prepared by PWOs for AR works contained a provision of one per cent of the cost of the work towards third party inspection. But audit found that no such inspection was carried out during execution which indicates that 44 PEs were inflated by ₹ 99.95 lakh.

Even CAPFs themselves had not made provisions of third party inspection in the agreements of their departmental works. In absence of independent third party inspection, the quality of works executed by all the executing agencies could not be verified.

CAPFs in their reply (June 2015) accepted the observation by stating that the third party inspection may be adopted in future. MHA in its reply (July 2015) admitted that this recommendation of audit is being examined for implementation.

**RECOMMENDATION:**

CAPFs should ensure that works are inspected by Quality Assurance Wing of the PWOs. Third party inspection clause should be incorporated in MoU to boost quality assurance levels.



**6.2 MONITORING**

Audit examination revealed lapses in monitoring by the executing agencies. A structure for multi layered monitoring is already in existence for construction activities. According to provisions of Chapter 10 of CPWD Works Manual, a preliminary survey of the site needs to be conducted before the preparation of the estimate for any work. Moreover, regular monitoring was to be done by executing agencies at the location/site of the construction works. CAPFs are required to detail a Board of officers to inspect the building and certify that the same has been constructed as per the approved drawings, detailed estimate and essential electrical and bulk services like road, sewers and water connection are completed and quarters are in a ready to move in condition.

Para 5.2 of Manual on Policies procedure for procurement of works issued by Ministry of Finance provides for putting in place project monitoring system before start of any work. At the highest level, MHA monitors the progress of construction works of CAPFs by taking quarterly meetings of the officers of CAPFs and executing agencies. This forms the multilayered monitoring at three levels, as shown here.



**6.2.1 Deficiencies in Monitoring**

Audit examination revealed lapses in monitoring by CAPFs as detailed below:

**6.2.1.1 Instances of non-monitoring**

CAPFs did not have a well-defined inspection policy for inspection/monitoring of construction activities. Audit found that the work of construction of 12 Type-II quarters at Jorhat, Assam of AR awarded by NPCCL to the contractor at a cost of ₹ 1.09 crore in October 2010, was poor since inception. The contractor used poor class shuttering

material, 'C' class bricks and low thickness slabs in construction. No action was taken by NPCCL. Though the contractor did not execute roof treatment work, internal and external water supply work, polishing of kota stone, NPCCL treated (April 2014) the work as complete. It shows poor monitoring of work by NPCCL and AR. Thus, even after 48 months since award, the 12 quarters could not be taken over and put to use although ₹1.09 crore was expended.

Similarly, in Lokra, Assam, 18 Type- II quarters<sup>1</sup> were constructed (April 2012) by a contractor at a cost of ₹ 2.65 crore. Inspection by AR revealed several serious deficiencies in work such as use of poor quality mortar mix, poor workmanship and use of pea gravels (river bed stones) instead of crushed stone due to which strength of the building reduced drastically. This indicated lackadaisical approach in monitoring on the part of AR during execution of the work, which compromised quality seriously.

#### **6.2.1.2 Lack of coordination between CAPFs and executing agencies**

It was noticed that regular meetings were not organized to sort out the issues between the Force and state governments and/or CPWD. Copy of the agreement entered upon with the contractor by the executing agency was neither provided by the executing agency to the client CAPFs nor asked for by the CAPFs. No periodical returns/reports in respect of the construction activities from the concerned executing agency were received on regular basis by CAPFs.

#### **6.2.1.3 Non-inspection by higher authorities**

Audit noticed that in 17 works carried out by CPWD and PWOs, no inspection was carried out by the higher authorities (IG & above) of CAPFs. It was found that where inspection was stated to have been carried out by the officers of CAPFs, in no case an inspection note was issued. In the absence of inspection notes, audit could not ensure the veracity or effectiveness of inspections carried out by officers of CAPFs. Audit also noticed that CAPF officials had not visited the offices of the executing agencies to ensure that the tender notice/award letters/agreement were as per the requirement of CAPFs.

CAPFs admitted the observation by stating that they had directed that remarks and feedbacks of higher authority (DIGs and above) during inspection of work site would be noted in Inspection Register.

#### **6.2.1.4 Non-constitution of Board of Officers for checking complete works**

CAPFs are required to detail a Board of officers to inspect the building and certify that the same has been constructed as per the approved drawings, detailed estimate and essential electrical and bulk services like road, sewers and water connection are completed and quarters are in a ready to move in condition.

---

<sup>1</sup> One of the package of construction of 12 type-III and 54 type-II, executed by EPIL

Audit noticed that in six works, Board of Officers (BOO) for checking of works did not comply with the provisions and handing over/taking over reports were not on record due to which audit could not verify that such works had been handed over/completed as per specification of PE/DE.

CISF in its reply accepted the observation by stating that board of officers requirement was not done as the works were taken over immediately after completion due to urgent requirement of the said infrastructures. The reply of the department was not in conformity with the above provision.

#### 6.2.1.5 Absence of project monitoring system

MoU between NPCCL and AR provided for compliance with Manual on Policies procedure for procurement of works issued by Ministry of Finance, GOI. Para 5.2 of this manual provides for putting in place a system of project monitoring system before start of any work. Para 5.2.2 also provided for availability of vital information such as construction schedule, progress chart, financial statement, statement of extra/substituted/deviated items, progress photographs results of quality testing, disputes, bottlenecks etc.

Audit, however, noted that such a system had not been put in place which could have facilitated better appraisal and effective monitoring of construction activities by AR. No record was available to ascertain whether AR took up the matter with the NPCCL for formulation of project monitoring system.

#### 6.2.1.6 Absence of Web based project monitoring system

CPWD has the facility of web-based monitoring, but CAPFs did not use the access to instant updates on construction activities. Web based project monitoring data was neither being provided by executing agency to the client department nor the client department asked for providing the said data resulting in weak monitoring system at the client level. Other PWOs did not have any facility for Web based project monitoring system. As such, CAPFs did not have access to instant updates about construction activities.

CAPFs admitted the observation for future compliance and the same shall be implemented after guidelines on the same are received from MHA. In reply, SSB stated that they would refer the audit observation to their Hqrs. for framing a policy on the matter.

#### RECOMMENDATION:

CAPFs should make practical use of the monitoring mechanism already in existence to bring meaningful results.

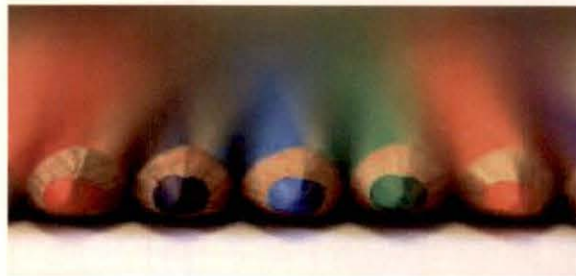

## 6.3 UTILISATION OF RESOURCES

### 6.3.1 Non utilisation of resources

Audit noticed that various residential and office buildings could not be handed over and put to use due to certain deficiencies like no provision of power supply, delay in energisation, incomplete development works viz. sewage, water connection, roads etc. Some instances where assets created were ready for utilization but could not be put in to use are depicted below:

- **Non-utilisation of completed infrastructure due to non-energisation of substation**

33/11 KV substation, 33 KV line and metering room at Disaster Management Training Centre (DMTC) at Latur for CRPF was installed (August 2011) at a cost of ₹ 2.50 crore. This was not energised due to failure of CRPF authorities in getting finalisation of route and Maharashtra Industrial Development Corporation (MIDC) approval and also due to non-deposit of requisite fees of ₹ 5.60 lakh to MIDC. Consequently, the completed infrastructure like Sewerage Treatment Plant, 33/11 KV station(Transformer), Compact substations, Street lights, Hospital, Administrative Buildings etc. were not put to use/functional even after incurring expenditure of ₹ 72.58 crores on the project.

NBCC confirmed the facts (August 2014). CRPF in its reply (June 2015) accepted the observation by stating that MIDC approval could not be received due to non finalization of lease deed due to difference in wordings of same between the format of MIDC and CRPF.

- **Non-operationalization of Indoor Shooting Range at NSG, Manesar**

Audit noticed that the construction of work Indoor Shooting Range at NSG, Manesar was completed in August 2008. However the handing/taking over was done in September 2012 i.e. after more than four years and the procurement of equipment could not be finalised even till December 2014. During inspection it was found that the electrical installations like ACs, lights etc were lying idle due non-operationalization of the building till December 2014 and termites spreading in the building.

NSG in its reply accepted the audit observation (June 2015) by stating that the composite Indoor Shooting Range was approved under Modernisation Plan-I and authorization of the



same did not exist and the case was being submitted in MHA. The delay was on account of procedural formalities and change of technology in respect of equipments and delay was not attributed to any specific unit.

### 6.3.2 Utilization of resources for other purpose

Audit examination revealed that buildings constructed for some specific purpose were utilised for a different purpose. Some instances in this regard are depicted below:

- Work of underground firing range for SSB at Kullu, Himachal Pradesh was undertaken by CPWD for ₹ 2.18 crore. NOC was issued by the local authorities for construction of underground firing range in October 2009. CPWD constructed indoor shooting range instead of underground firing range. The indoor shooting range had not been put to intended use. SSB was planning to use the same for other purpose like auditorium, indoor classes etc.

SSB in its reply (June 2015) stated that for close Combat Arms Shooting Range, it proposed for Indoor shooting range having specification meeting the requirement of underground effect which had been taken care of while designing the Indoor close combat arms range by CPWD. The reply was not acceptable as for obtaining NOC SSB applied for underground firing range by stating that as it will be highly safe and secure & NOC was issued for underground firing range by the District Magistrate after inspection of the site.

- The work construction of Magazine Building (for storing of ammunition) with allied services and development works at Kakching, Manipur of AR was awarded by NPCCL in November 2009 and work was completed in September 2012 at a cost of ₹ 1.08 crore. Audit found that the magazine building was being used as Rehabilitation Centre. No sanction existed for utilisation of the building for other purposes.

Assam Rifles admitted (April 2015) the observation by stating that they would ensure that the required building will be put to use for intended purpose.

- The work of 120 men barrack including Kitchen, Dining Hall, Recreation hall for GC CRPF, Pune was completed after incurring an expenditure of ₹ 5.89 crore and handed over to the CRPF in October, 2009. However, during site visit, audit noticed that one barrack was being used for Kendriya Vidyalaya (KV), another for Institute of IED Management and the third barrack is emptied for renovation purpose.

CRPF in its reply (December 2014) stated that in order to continue smooth running of KV and IED Institute, his office accommodated them in the Barracks in pursuant to the instructions received from the competent authority. Reply was not acceptable as it indicated that CRPF approved the works without any real need and constructed Men Barracks without examining the necessity which had resulted in utilization of barracks other than intended purpose.



- NPCCL handed over construction of 04 SM Barrack at Jwalamukhi and Maram, Manipur in June 2013 to AR with total cost of ₹ 6.27 crore. Audit found that SM Barracks constructed became unusable immediately after taking over and were used as Godown. AR did not take any action in this regard.
- AR got the construction of 3 SM Barracks for 6 NCOs and 60 Qrs (G+II) and 1 Admn Block at Kakching, Manipur through NPCCL with a cost of ₹ 1.32 crore. But audit found that 3 SM Barracks were used as School.
- 15 blocks of 90 type-II quarters at Radhanagar, Tripura were completed by NPCCL at a cost of ₹ 7.34 crore and handed over to AR up to March 2011. Audit, however, found that AR had been using one block of type-II quarters as hospital since April 2011 as the construction of the hospital building had not been completed. Utilization of quarters for other purposes for the past three years indicated that the quarters were not of any immediate use for intended purpose.

Assam Rifles admitted (April 2015) the above observations by stating that they would ensure that the required buildings will be put to use for intended purposes.

- ₹ 98.38 lakh was incurred towards providing/erecting/laying of VCB Panels/Breaker, UGHT Cables and 3 numbers of 250 KVA transformers for providing electricity connection to 208 quarters in Bengaluru. Since the underground cables laid were damaged, power supply could not be provided to the quarters from the BESCOM Sub-station and the equipment/installations are lying idle since April 2012 i.e. from the date of their installation. Further, it was also noticed that ₹ 21.20 lakh incurred towards purchase of 208 electronic energy meters, and service charges for BESCOM power supply, were also idling since March 2012 since the electricity connection is not provided till date.

CRPF in its reply accepted the observation and stated that CPWD was primarily responsible for providing electric connections in mutual consultation with BESCOM. During joint inspection, it was observed that the meter rooms were being used as store rooms for storing broken materials and other obsolete items.



An interesting case in this regard has been depicted below as case study:

### Case Study 6.1

NPCCL awarded the work C/o 20 bedded Hospital including allied services and Development works for AR at Haflong, Assam at a cost of ₹ 2.18 crore in May 2009. Besides other structures, a separate female ward for lady patients, labour ward and delivery room were also constructed.

After completion of construction of Hospital building it started functioning since April 2013. Audit, however, noticed that none of the female wards were put to use even till October 2014 although ₹ 29.34 lakh had been expended on construction of these services. In fact, the female ward and labour ward was being used as store room for medicines and lodging purposes respectively.



All the above cases clearly show that the expenditure incurred for construction was not utilized for the intended purpose. Assam Rifles admitted (April 2015) the observation by stating that they would ensure that the required building is put to use for intended purpose.

### RECOMMENDATION:

CAPFs should initiate construction activities only after their priority assessment so that the buildings are put to immediate use for intended purpose.



## 6.4 MAINTENANCE OF RESOURCES

Construction activities in CAPFs had resulted in creation of large number of capital assets viz. office and residential buildings, BOPs and barracks. After handing/taking over of buildings, maintenance of the same is essential for its proper up-keep and extended life span. Inadequate maintenance in the building leads to deterioration of building prematurely and can even threaten safety. Regular maintenance enables timely identification and rectification of deteriorated building elements, and is therefore, a must.

Earlier, all the construction works of CAPFs were executed by the CPWD. Maintenance of all office/residential building was the responsibility of the CPWD. The works executed by PWOs viz. NBCC, EPIL, NPCCL, HPL etc. for CAPFs were not being

maintained by PWOs as no provisions for maintenance of building were incorporated in their MoUs. CPWD was not ready to maintain these buildings on the plea that these buildings were not constructed by them. If it were to be maintained by the same PWO who constructed it, it was found that they were demanding exorbitant charges for maintenance i.e. up to 20 per cent of estimated cost of construction as agency charges for maintenance. CAPFs were not ready to award maintenance contract to these PWOs due to paucity of funds. This has resulted in non-maintenance/poor maintenance of the assets of CAPFs created by these PWOs. Audit noticed instances during joint inspection such as seepages on the wall, rusting of iron, broken water pipes, damaged railings, clogging of drainage channels etc.

MHA in their reply (July 2015) accepted the observation by stating that as suggested by the audit, this Ministry would consider the possibility of making an amendment in the MoU to be signed by CAPFs and PWOs for execution of work prescribed by MHA for maintenance of the building constructed by the concerned PWOs. Amount for maintenance of buildings is being provided to CAPFs under Sub-head Minor works.

### RECOMMENDATION:

CAPF may incorporate provision for maintenance of buildings in the MoU itself to take care of their maintenance. CAPFs with Engineering wings may undertake this process internally



## 6.5 CONCLUSION

Audit examination revealed lapses in quality assurance as there was no system of inspection by quality assurance wing of CPWD and PWOs do not even have quality assurance wing. There was no provision of third party inspection. Audit noticed poor maintenance of buildings, barracks and residential accommodations of jawans. CAPFs did not have a well-defined inspection policy for inspection/monitoring of construction activities. No inspection was carried out by the higher authorities and where inspection was carried out by the officers of CAPFs, no inspection note was issued in any of the cases. No web based project monitoring system exists in PWOs.

One of the key to efficiency and effectiveness is the coordination among the agencies involved in construction. It appeared that the activities undertaken by agencies and coordination between them was not calibrated properly. This was reflected in the questionable quality of assets created and their maintenance. Proper up-keep of these multi-crore assets was also not found satisfactory in many cases.

## CHAPTER – VII

# Financial Irregularities

In construction activities, financial management is a vital aspect. Financial planning for the project is intended to ensure that a firm plan with adequate safeguards and contingency plans are in place before the project is started and it is required to ensure that the plan is properly executed over the life of the project. Further, as per GFR, every officer is responsible for financial prudence during financial management of the projects. However, it was noticed that financial irregularities existed during execution of projects as explained in succeeding paras. This chapter does not contain the cases of cost escalation which were elucidated in Chapter-IV and V. This chapter only contains cases of deviation from the financial rules and regulations and its monetary impact.

## 7.1 Mobilization Advance

Mobilisation advance is an advance paid to the contractor in order to mobilise his resources for starting the work. Para 32.5 of CPWD works manual stipulates that in respect of certain specialized and capital intensive works with estimated cost put to tender of ₹ 2.00 crore and above, provision of mobilization advance may be kept in the tender documents. As per the provisions of the MOU/agreement, PWOs are required to maintain a separate project account for each work. As per provisions of CPWD manual and instructions of CVC, interest was to be charged on mobilization advance for the period not adjusted. The CPWD Manual also envisages that recovery of 100 *per cent* mobilisation advances by the time 80 *per cent* work stands completed should be made. As per practice in vogue, CAPFs gives mobilize advance to PWOs, which in-turn grant it to contractors.

Audit examination of records revealed instances of non-maintenance of separate project account for mobilization advance, non-accountal of interest, irregular payment, excess payment, non recovery/adjustment, improper utilization of mobilization advance which were as follows:

- In 20 works, mobilisation advances amounting to ₹ 87.64 crore were given by the CAPFs to the executing agencies, but no separate project account for mobilization advance was maintained by the executing agencies due to which account of interest/adjustment of mobilisation advance could not be ascertained (**Annex 7.1**). NBCC did not offer their comments.
- Mobilization advance of ₹ 4.81 crore was paid for CRPF Group Centre, Bahalgarh, Sonipat (Haryana) during September 2012. It was required to be adjusted from the bills raised by NBCC as per provisions by May 2014, though 80 *per cent* of works had been completed, it was still outstanding as of December 2014.

- NBCC obtained mobilization advance of ₹ 33.78 crore for executing seven works at GC, CRPF Bahalgarh, Sonipat (Haryana) for onward advancing to contractors engaged for execution of works but only ₹ 6.59 crore was given to the contractor. Thus, the advances taken from the client department amounting to ₹ 27.19 crore were not fully utilized / invested for the intended purpose.

Further, as per standard format of MoU issued by MHA in May 2011, mobilisation advance was to be given at the rate of 10 *per cent* simple interest. However CRPF entered into MoU with NBCC in September 2012 without quantifying the rate of interest and gave an advance of ₹ 33.78 crore for executing above seven works, out of which NBCC gave only ₹ 6.59 crore mobilisation advance to contractors at the rate of interest of 13 *per cent* instead of prescribed 10 *per cent per annum* rate of interest and collected ₹ 55.39 lakh as interest from the contractors which was not adjusted in the works account. They released the bank guarantees without adjusting the interest on mobilization advance.

In its reply, CRPF admitted the facts and stated that the bank guarantee was released as per directions from Director General CRPF. Reply was not convincing as the conditions of MoU/codal provisions were to be followed in letter and spirit.

## 7.2 Non- levy of liquidated damages

As per clause-2 of General Conditions of Contract, compensation or liquidated damages (LD) at the rate of 1.5 *per cent* per month for delay in completion of work, computed on per day basis, not exceeding 10 *per cent* of the tendered value of work should be recovered.

It was noticed that, although there were delays up to 56 months in completion of 58 works, no compensation/LD charges amounting to ₹ 19.86 crore were levied on the contractors (**Annex-7.2**). In each case CAPFs authorities granted Extension of Time (EOT) as per clause of the agreement. It indicated that either executing agencies/CAPFs were responsible for delays in the works or contractors were given undue benefits by not levying LD charges for delays.

CRPF and SSB in their reply (June 2015) accepted the observation and stated that LD Charges would be recovered from the Running Bills of the NBCC as per provisions contained in the MoU. CPWD authority is preparing bills at their own level, hence, LD are being recovered by PAO from them accordingly as per provisions.

A notable example for levying of LD was observed in AR. EPIL divided the construction of 48 Type-II quarters at Jorhat, Assam into 3 works (16 quarters each) and awarded the works at the same time (May 2006) to three different contractors. Two contractors completed the work in April-May 2008. But the third contractor completed the work only in May 2011. The AR granted extension of time on grounds of heavy rainfall, ethnic violence, road block, steep hike in construction material etc. without imposing liquidated damages. As other two contractors could complete the work by April-May 2008, the

justification of AR not to impose LD on third contractor was improper, especially as the site for construction of these three contractors was same.

## 7.3 Excess Payments

### 7.3.1 Excess payment to contractors

CPWD Manual as well as general conditions of contract have provisions for price escalation of items such as steel and cement under certain conditions. However, it was noticed that in 49 works (**Annex-7.3**), an excess payment of ₹ 6.42 crore over the contractual stipulation was made to the contractors/PWOs. The excess payments made were mainly due to wrong calculation of price index, escalation of labour rates, cement and steel rates etc.

NPCCL replied (December 2014) due to oversight, the item was included and due care shall be taken in future to avoid such kind of lapses. CRPF in its reply stated that release of excess payment to contractor was done by CPWD / PWO as they release project wise payment to the CPWD/PWOs. Assam Rifles admitted (April 2015) the audit findings by stating that over paid amount would be recovered from the concerned agency and they would ask PWOs to include such provisions in the contract. SSB in its reply accepted the observation and stated that the executing agency was asked time and again and the same would be continued for the works to come up.

### 7.3.2 Payment of secured advance without procurement of material

As per clause 10 B(i) of General Conditions of Contract, the contractor shall be entitled to secured advance up to 90 *per cent* of the assessed value of any materials brought on the site, during the progress of the execution of work.

Audit noticed that in the work C/o combined building of administrative block / quarter guard / store block and trade men shop for, CRPF at Khunti, Jharkhand, ₹ 1.17 crore was paid as secured advance by CPWD without procurement of construction materials by the contractor. Besides, the joint physical verification (July 2014) disclosed that no materials were available at the work site against which secured advance was paid. No material of site account/stock account was furnished to Audit.

CPWD in its reply stated that secured advance was paid to the agency for the materials which were brought at the site. The work was stopped by the villagers. It further stated that the amount for acquisition of land was paid to the state but unfortunately till date, the state government had not made any arrangement for payment to the villagers. The reply of the department was self explanatory which indicated that even the land had not yet been acquired and an amount of ₹ 1.17 crore was paid as secured advance to the contractor which was irregular and indicated undue favour to the contractor.

### 7.3.3 Non-recovery of compensation

- In two cases, the amount of compensation due to recession of work levied on the contractor was not recovered by the executing agency. In one work, C/o 386 Nos. Type-II quarters including internal water supply, sanitary installation and electrification etc for CRPF Group Centre at Kadarapur, Gurgaon was awarded to a contractor at a tendered cost of ₹ 11.66 crore in September 2002 with stipulated date of completion as September 2004. The work could not be completed by the contractor and the work was rescinded in June 2006. The total payment made to the contractor was ₹ 6.16 crore till the rescission of the contract. As per Clause-2 of the agreement, compensation was to be levied by the CPWD from the contractor. CPWD issued notice for levy of compensation for delay at the rate of 10 per cent of the tendered value of the work for ₹ 1.14 crore in July 2006 and issued instructions to withhold an amount of ₹ 1.03 crore and no amount should be released to contractor without recovery of aforesaid amount. In absence of records, audit could not ascertain if the amount has been recovered from the contractor by CPWD.
- The work C/o 2 Nos. 180 men barrack at Behror, Rajasthan for CISF was awarded to a contractor by CPWD at tendered cost of ₹ 529.10 lakh in December 2004 with the stipulated date of completion as June 2006. Work was not completed by the contractor even up to August 2007. Department did not take punitive action against the contractor during the period of validity of contract. It unilaterally extended the contract up to June 2008 without the consent of the contractor. It issued show cause notice in February 2008 and rescinded the work in August 2008 by imposing compensation of ₹ 52.51 lakh. As there had been no valid contract after August 2007, action of department to issue show cause notice and rescission of work was lacking legal sanctity. On rescinding the work, the contractor approached the arbitrator who decided the matter in his favour stating that the action of department was unlawful and uncontractual awarding ₹ 52.91 lakh along with 9 per cent interest of ₹ 21.65 lakh from January 2009 to till date of payment i.e. August 2013. Thus, due to wrong rescission of work, department had to pay ₹ 21.65 lakh as interest which could have been avoided.

CPWD did not offer their comments in both cases.

### 7.3.4 Avoidable expenditure of ₹ 81.45 lakh

CRPF decided to construct an approach road at Kadarapur in March 2005 and requested CPWD to submit estimates. CPWD submitted estimates of ₹ 65.01 lakh in July 2005 and ₹ 84.40 lakh in January 2006 due to change of scope. CRPF HQ rejected the proposal in February 2006 as the proposed construction site belonged to State Government and not CRPF. The matter was taken up with State Government which asked CRPF to deposit funds for the project as they were not having sufficient funds. Instead of taking up the matter at the higher level, CRPF acquired the additional 3 acre state government land and constructed the road after incurring an expenditure of ₹ 81.45 lakh. CRPF incurred

avoidable expenditure of ₹ 81.45 lakh on construction of road in addition to cost of additional land acquired for this purpose.

CRPF accepted the observation and stated that avoidable expenditure was occurred due to non-availability of good road connectivity.

#### 7.4 BANK GUARANTEE

As per Central Vigilance Commission (CVC) guidelines contractors should be insisted upon Bank Guarantees (BGs) to be submitted by them and sent to the organization directly by the issuing bank under Registered Post (AD). In order to safeguard the interests of the government, bank guarantees are obtained from the contractors, so that in case some defects creep in during or after execution, the same are rectified at the cost of contractor. Bank guarantee should not be released before fulfilment of the conditions of MoU. However following instances revealed irregularities in handling the bank guarantees:

- **Non-renewal/encashment of bank guarantee**

In 2 works executed by CPWD at Srinagar (CRPF & ITBP), it was noticed that the CPWD was not prompt in renewal of bank guarantee (BG) due to which they became time-barred while the work was in progress. The details are given below:

Table-7.1

(₹ in lakh)				
S.No.	Name of the work	Force	Period for which bank guarantee not renewed	Amount
1	C/o Sos Mess and dormitory for SHQ ,ITBP Leh	ITBP	12.8.13 to 31.12.13	20.54
2	C/o 117 Nos Qtrs in CRPF Srinagar	CRPF	Since 31.12.10	7.03
<b>Total</b>				<b>27.57</b>

The executing agency in its reply stated that the concerned bank had been requested to revalidate the bank guarantees. The reply of the agency is to be seen in light of the fact that the concerned contractor was to revalidate the BG and not the bank.

- **Submission of fake Bank Guarantee (BG)**

Audit noted that the construction of 24 Type-II quarters of AR in Kangvai, Manipur with estimated cost of ₹ 4.81 crore was awarded in March 2010 and NPCCL paid ₹ 65.56 lakh to contractor during the period 25.3.2011 to 13.5.2011, without verifying the authenticity of two bank guarantees amounting to ₹ 20.34 lakh submitted by the contractor on 25 March 2011. After a lapse of one year NPCCL submitted the BG to the issuing bank for verification; the issuing bank confirmed that the BG submitted by the contractor was fake. This work was suspended for the last 3 years due to litigation on the matter of fake



bank guarantee submitted by the contractor. Thus, non-adherence to the CVC guideline by NPCCL resulted in delay in completion of the work.

- **Delay in submission of Performance Guarantee (PG)**

MoU concluded between AR and the PWOs stipulated that the general conditions of contract as specified in the agreements concluded by CPWD would be followed. The agreement of CPWD works stipulated forfeiture of Earnest Money Deposit (EMD) in the event of failure of the contractor to furnish Performance Guarantee (PG) within 15 days of issue of letter of intent (LOI). Examination in audit revealed that in 26 cases despite average delay of 5.8 months in furnishing the PG, the PWOs did not forfeit the EMD to tune of ₹ 2.15 crore (**Annex-7.4**). AR did not initiate any action to impress upon the PWOs the need for strict compliance with the safeguard clauses contained in the Agreement.

## 7.5 STATUTORY RECOVERIES

At the time of releasing payments of work to the contractor, CAPFs/executing agencies are required to deduct the statutory recoveries viz. Works Contract Tax (WCT), Worker's Welfare Cess, Royalty, TDS, VAT/Sales Tax, etc. from their running account/final bills as per laid down provisions. However, following instances were noticed where irregularities in recovery of statutory dues were found:

- Works Contract Tax (WCT) was to be deducted at the rate of 4 *per cent* of the total value of work done. However it was noticed that in 5 works (**Annex-7.5**), irregularities amounting to ₹ 14.33 lakh were noticed due to short / excess/ non-recovery of WCT from the contractors and excess deposit of WCT to state government.

In reply, Assam Rifles admitted the audit observation by stating that the variation in deduction of WCT was due to late receipt of WCT notification from respective State Governments.

- Audit found that in six works (**Annex-7.6**) relating to AR executed in Assam between August 2008 and October 2010, NPCCL / EPIL instead of the applicable rate of 4 *per cent* paid WCT at 9.375 *per cent* of the total value of the work to Assam Government. Consequently, there was excess payment of ₹ 82.00 lakh to the State Government. Neither AR nor NPCCL/EPIL furnished any reason for such excess payment.

In its reply (April 2015), EPIL stated that 4 *per cent* could not be applied as none of the contractors had submitted their registration certificate, owing to absence of such a provision in their contract. The contention of EPIL was not tenable as the rates quoted by the contractors were exclusive of WCT and AR who were directly depositing the WCT to the state government could have regulated the payment at 4 *per cent* immediately on notification by the State government. Moreover, AR

before making payment of WCT at higher rate of 9.375 *per cent* did not verify whether the contractor had registered with the state government and were not availing financial benefit by way of refund of 5.375 *per cent* (9.375 – 4) of WCT from the state government.

- As per the provisions of ‘Building and other works’ Cess Act, 1996, the labour cess @ 1 *per cent* was to be deducted from the payment of contractor for construction work and amount was to be deposited with the Board. However, it was noticed that in 112 works (**Annex-1.3**), labour cess amounting to ₹ 2.17 crore was not deducted and deposited.

CRPF and SSB in their reply (June 2015) accepted the observation by stating that labour cess at the rate of 1 *per cent*, which was paid to the NBCC had already been recovered by the PAO. In the case of CPWD, labour cess was being recovered. BSF in its reply (June 2015) stated that the departmental work in which labour cess was not deducted were those works which were awarded prior to order for deduction of labour cess. Reply was not acceptable as work contract tax was applicable since September 1996. Further, DG BSF admitted the audit contention by saying that necessary instruction had been issued to the concerned Frontier Hqrs. to deduct the WCT and labour Welfare Cess at the rate applicable in the state.

- As per clause 37(II) of General Condition of Contract “The contractor shall deposit royalty and obtain necessary permit for supply of the red bajri, stone, kankar, etc. from local authorities. As per Rajasthan state government rules, 1 *per cent* of bill value from October 2008 and 2 *per cent* of bill value from 15 November 2011 should be deducted from contractor’s bill. However in 24 works (**Annex-7.7**), royalty amounting ₹ 67.48 lakh was not recovered and deposited with state government.
- As per Sec.194 (J) of the Income Tax Act, 1961, Income Tax @ 10 *per cent* of the gross value of the work is required to be deducted at source from the Consultants and Professionals and under Section 194(c) of the Act any person responsible for paying any sum to any resident contractor/sub-contractors is required to deduct Income-Tax, at source, at the rate of two *per cent* /one *per cent* respectively from any sum credited or paid in pursuance of any contract. Audit scrutiny of records revealed that in 2 works of CRPF (**Annex-7.8**), TDS amounting ₹ 44.26 lakh was not deducted by CPWD & NBCC and deposited with the concerned authorities. CPWD/NBCC did not offer their comments.
- As per Rajasthan Value Added Tax Act 2003, at the time of making payment 3 *per cent* of bill value and in case of exemption 1.50 *per cent* of bill value should be deducted from contractors. Audit noticed that in 3 works of BSF and CISF, VAT amounting ₹ 0.78 lakh was not deducted by CPWD (**Annexe-7.8**). CPWD did not offer their comments.

### RECOMMENDATION:

CAPFs should impose penalty in case of defaults in utilizing the advance. CAPFs should put requisite checks in place to ensure deduction of statutory provision such as Works Contract Tax at prevailing rates.



## 7.6 SHORT-DEDUCTION OF SECURITY DEPOSITS

As per section 21.2 of CPWD, Manual, security deposit shall be collected by deductions from the running bill of the contractors. A sum @ 5 per cent of the gross amount of the bill shall be deducted from each running bill of the contractor, till the sum along with the sum already deposited as earnest money amounts to security deposit @ 5 per cent of the tendered amount of the work. Such deductions shall be made unless the contractor has deposited the amount of security at the rate mentioned in cash or Government securities or Fixed Deposit Receipts. This is in addition to the performance guarantee that the contractor is required to deposit as per para 21.1 (3) of CPWD works manual.

Audit noticed that security deposits to the tune of ₹ 1.60 crore was not deducted from bills of the contractors by executing agencies in 38 works (**Annex-7.9**). Less deduction of security deposit does not provide security of the work executed beyond agreement value.

CPWD/PWOs and CAPFs except SSB did not offer their comments. SSB (June 2015) accepted the observation and stated that now due care would be taken.

## 7.7 DIVERSION OF FUNDS

As per provision of sections 51.2(3) and 51.2(5) of CPWD Works Manual voted and charged portions of the budget, as also the revenue and capital sections of the grant/appropriation are distinct, and re-appropriation inter-se is not permissible, and an excess in any one portion or section is treated an excess in the grant or appropriation. Similarly, savings and surrender should also be avoided. Large savings are indicative of loose budgeting in the sense that these prove the inability of the department to spend usefully the funds to the extent anticipated.

In six works (**Annex-7.10**), it was noticed that an amount of ₹ 1.92 crore was diverted to works not forming part of the main works.

CPWD while admitting the diversion of funds stated that there was a provision of contingencies in each and every AA/ES under which miscellaneous related works were carried out and the expenditure was made towards other developmental works

complementary to the main work. The reply was not acceptable as expenditure from contingency of the work was well defined in the CPWD manual which prohibits such type of expenditure and as such saving of one work can not be utilized for other work.

## 7.8 OTHER IRREGULARITIES

- **Non-deduction of void in earth filling**

In three cases while making payment for earth filling work and stacking of stone metal, the mandatory 10 per cent and 7.5 per cent deduction respectively towards void was not made thereby extending undue benefit to the contractor to the tune of ₹ 5.37 lakh (**Annexure-7.8**).

- **No soil testing**

As per section of 2.7 of CPWD works manual, preparation of site/soil data was required to be done at pre-construction stage of execution of a work.

However, in 3 cases, NPCCL did not adhere to the above provision and awarded the work without soil testing. After soil testing, the design of the foundation was to be revised as per requirement of site which resulted in avoidable expenditure of ₹ 40.13 lakh in 2 works and expected minimum liability of ₹ 21.28 lakh in one work (**Annex-7.11**).

NPCCL in its reply stated that as per agreement any additional item, for which no rate is specified in contract, shall be worked out based on DSR. Reply was not tenable as had the soil testing been carried out prior to preparation of estimate, "Strip Footing" item would have been incorporated in the estimate; rate of which was less than the analysed rate of "Strip Footing". Assam Rifles admitted (April 2015) the audit findings and further stated that soil testing would be ensured in the pre-construction stage by the agency.

## 7.9 CONCLUSION

Financial irregularities noticed during audit are depicted below:

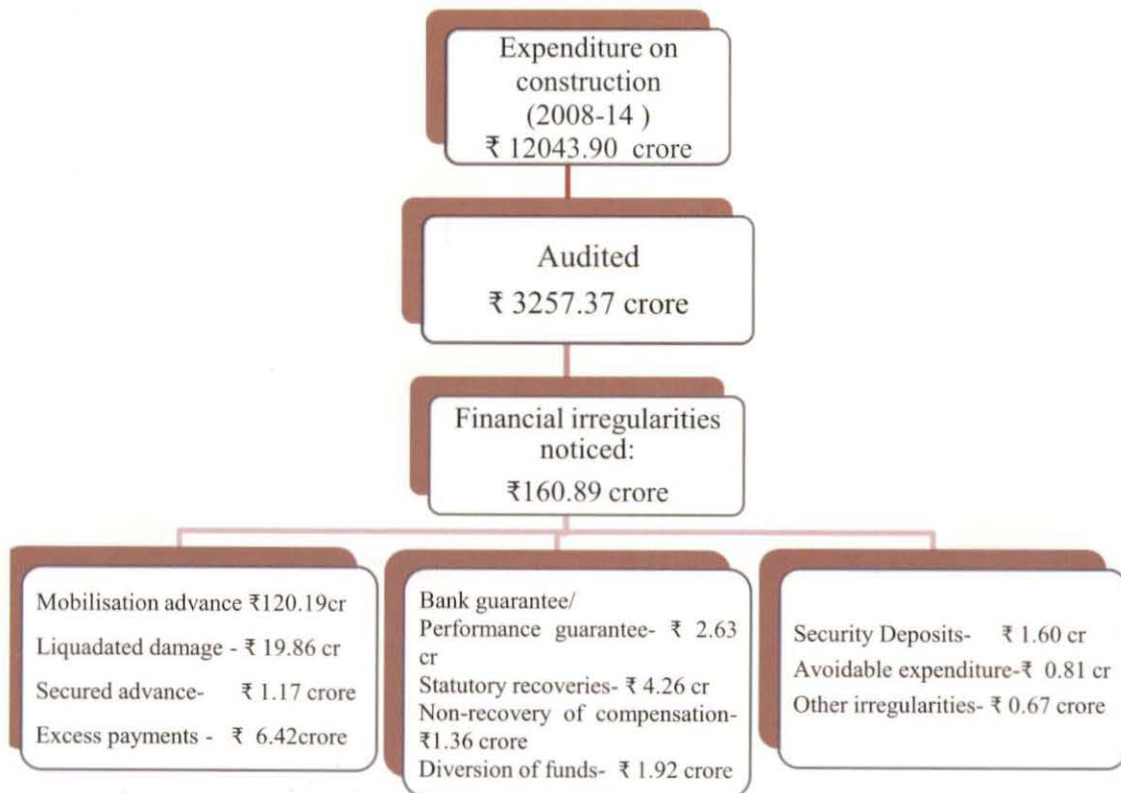

It was noticed that there were irregularities in granting mobilization advance, non-maintenance of proper accounts, non-adjustment of mobilization advances, submission of fake bank guarantees and premature release of bank guarantees. Besides, cases of diversion of funds and excess payments were also noticed which showed improper monitoring on the part of CAPFs. The executing agencies were also not deducting the statutory recoveries. There is thus, a need for CAPFs to strengthen the mechanism of financial monitoring.

## CHAPTER –VIII

## Construction Activities - Force wise

In the previous chapters, irregularities noticed during execution of construction works have been discussed in detail. However, as CAPFs, being the end user, are responsible for overall monitoring of construction works. Audit presents a bird's eye view of the construction activities force wise which were compared on the following parameters:

1. Selection of executing agency
2. Scrutiny of preliminary estimates submitted by executing agencies
3. Accord of administrative approval and expenditure sanction
4. Monitoring of works from award of contract till completion by executing agency
5. Financial irregularities
6. Taking over of assets created
7. Maintenance and Utilisation of assets

The analysis was done based on the following data.

**Table 8.1: Force-wise details of works**

(₹ in crore)				
Name of Force	Total number of selected works	Executing Agencies	Number of states in which works executed	Sanctioned Amount
AR	132	Deptt. 5 PWOs 127	8	631.09
BSF	155	CPWD 92 Deptt. 42 PWOs 21	22	407.27
CISF	61	CPWD 55 PWOs 6	11	245.02
CRPF	171	CPWD 151 PWOs 20	21	1257.31
ITBP	102	CPWD 75 Deptt. 25 PWOs 2	17	279.19
NSG	14	CPWD 9 Deptt. 5	2	68.47
SSB	75	CPWD 56 Deptt. 16 PWOs 3	9	369.01
<b>Total</b>	<b>710</b>	<b>CPWD 438 Deptt. 93 PWOs 179</b>		<b>3257.36</b>

## 8.1. SELECTION OF EXECUTING AGENCY

There are no fixed criteria for selection of executing agency by CAPFs. As discussed in Chapter-II, CAPFs either got the work executed through CPWD by placing the sanctioned amount of the work at the disposal of CPWD or selected other PWOs on nomination basis for execution of work. The distribution of work among PWOs by CAPFs was as follows:

**Chart 8.1: Selection of executing agencies by CAPFs**

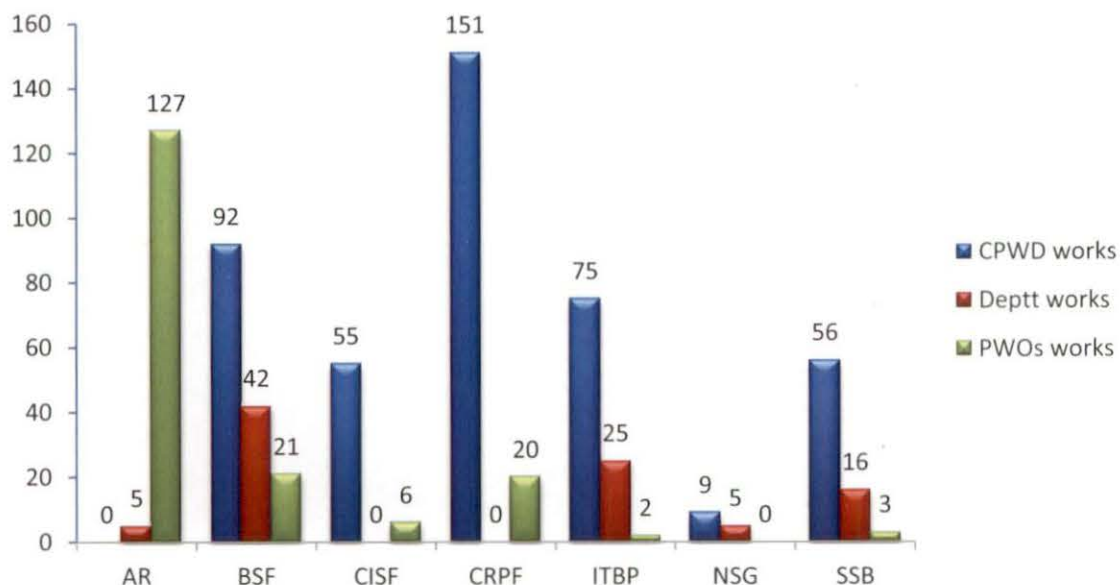

AR did not award any work to CPWD and selected other PWOs on nomination basis for execution of their works on the plea that CPWD delays the projects which results in time and cost overrun. However, both these problems existed in other PWOs also. There should be a uniform transparent system in CAPFs for competitive bidding for selection of executing agencies including CPWD.

## 8.2. SCRUTINY OF PRELIMINARY ESTIMATES SUBMITTED BY EXECUTING AGENCIES

Audit found that executing agencies took up to 56 months in submitting the PE after receipt of requisition from CAPFs. It was found that this undue delay was never monitored by CAPFs. Though executing agencies prepare the preliminary estimates based on the Delhi Plinth Area Rates (DPAAR), it was the responsibility of CAPFs to ensure that estimates prepared are as per their requirement and include all the items necessary for construction works. However, audit noticed that in the following cases, CAPFs failed to properly scrutinize the PEs which resulted in change of scope at later stage, cost escalation and time overrun (as detailed in Chapter-IV) :

Table 8.2: Force-wise audit observations in Preliminary estimates

(₹ in crore)

Name of Force	Improper assessment of requirement	Failure in pre stage construction	Preparation of incorrect PE	Non-inclusion of items in PE	Total
AR	39.36	-	1.40	15.26	56.02
BSF	-	-	0.09	-	0.09
CISF	0.69	-	-	-	0.69
CRPF	-	2.21	12.73	-	14.94
ITBP	0.77	-	-	-	0.77
<b>Total</b>	<b>40.82</b>	<b>2.21</b>	<b>14.22</b>	<b>15.26</b>	<b>72.51</b>

### 8.3. ACCORD OF ADMINISTRATIVE APPROVAL & EXPENDITURE SANCTION

The scrutiny of PEs is done by CAPF to accord the administrative approval and expenditure sanction (AA&ES) by MHA/CAPFs as per the orders issued by MHA in respect of delegation of financial powers. Though there is no time limit specified for according the AA & ES, audit calculated a reasonable time of five months. It was noticed that time taken in according the AA&ES sanction by MHA/CAPFs was up to 76 months. The reasons for this delay were not found on record. The percentage of works in which time taken was more than average of five months and its corresponding sanctioned amount is shown in the following chart:

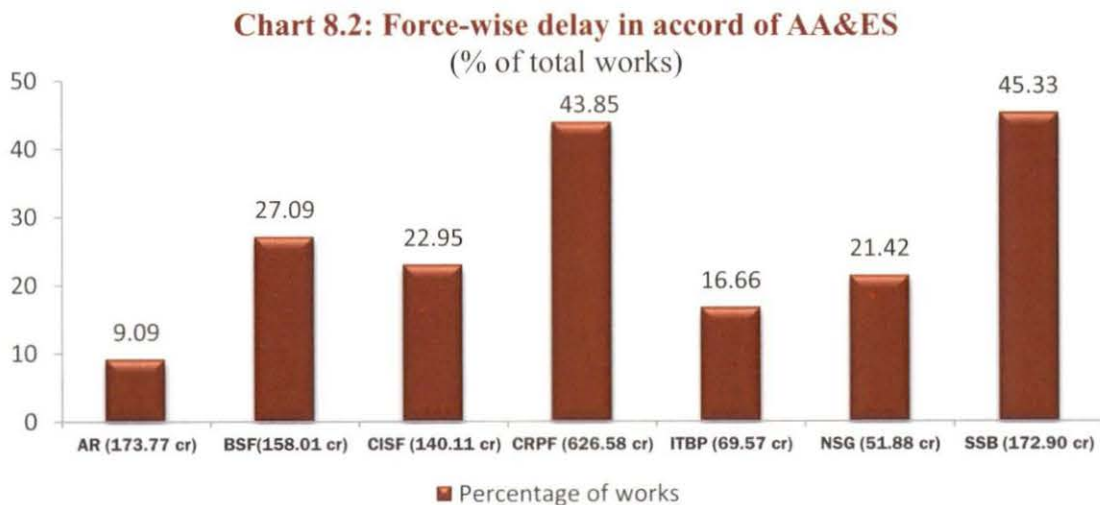

It clearly shows that more than 45 per cent and 44 per cent of the selected works of SSB and CRPF respectively were delayed in according the AA & ES. The undue delay in granting of AA & ES had a cascading effect on the whole project, rendering AA & ES



irrelevant in many cases. The reasons for taking such time in according approval of AA/ES were, however, not available on records.

#### 8.4. SPLITTING UP OF WORK

Besides delay in AA & ES, it was also noticed that works were split up by CAPFs to avoid taking sanction of the higher authorities and cases were also noticed where the expenditure exceeds 10 per cent of the AA & ES but revised sanction, as required by CPWD Manual, was not obtained/taken by CAPFs as detailed below:

Table 8.3: Force-wise details of splitting up of works

(₹ in crore)		
Name of Force	Amount involved in the works split up	Amount of work where revised sanction not taken
		Amount of AA & ES
BSF	38.21	4.08
CISF	-	4.79
CRPF	166.00	18.44
ITBP	-	17.28
NSG	2.41	0.15
SSB	-	5.61
<b>Total</b>	<b>206.62</b>	<b>50.35</b>

CAPFs should stop the splitting up of the works in order to avoid the sanction of higher authority i.e. MHA. CAPFs were required to be more vigilant especially in financial matters and revised sanction should have been obtained as the expenditure exceeded 10 per cent of the sanctioned cost.

#### 8.5 LACK OF MONITORING BY CAPFs FROM AWARD OF WORK TILL COMPLETION

Executing agencies are to follow the tendering process and are required to award the work to the eligible and lowest tenderer and also to ensure that the work be completed in time. However, CAPF, being the end user, are also required to monitor the process of awarding the work and also periodically monitor the progress of the work to ensure its timely completion. They are also required to raise alarm from time to time regarding the timely completion of work. It is important to mention here that out of 240 works where delay in awarding the works was more than six months, 34 works (14 per cent) were executed by CAPFs themselves.

Chart-8.3: Percentage of works awarded after six months

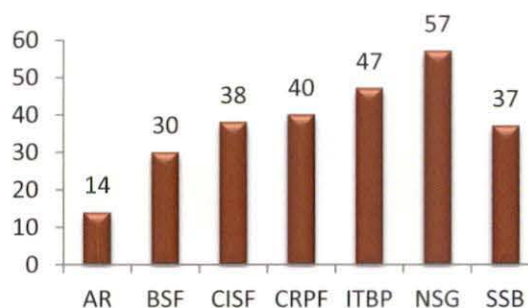

While the executing agencies were responsible to a large extent for delay in award and completion of work, the role of CAPFs for these delays cannot be discounted.

Audit observed lack of follow up at two stages, one, liaison with PWOs to see that contracts are awarded on time and during construction. Here again, there were no yardsticks to adhere to. A reasonable time frame (six months) based on average time taken was the basis for this analysis. About 50 per cent of works could not be completed in time in all CAPFs. It was indicative of poor monitoring of the projects by the CAPFs and not pushing the timelines effectively with the executing agencies. The delay in award and completion of works were attributable largely due to problems in coordination and adjustments in estimates. None of the works audited were completed on time and it was seen in all organizations. This includes minor delays starting from one month to major delays up to 7 years. 63 works (16 per cent), where works were completed after due date, were executed by CAPFs. It indicates that effective monitoring mechanism was not present in CAPFs due to which they did not monitor the works executed by themselves.

**Chart-8.4: Percentage of works completed after due date**

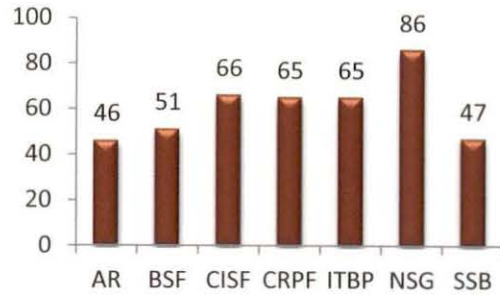

### 8.6 FINANCIAL IRREGULARITY

Audit found financial irregularities amounting to ₹ 160.89 crore in 390 works. These irregularities includes non-maintenance of account of mobilisation advance, non-adjustment of mobilisation advance and interest thereon, diversion of fund, non recovery of liquidated damages and non/short recovery of statutory dues. The force wise position is as follows:

**Chart 8.5: Financial Irregularities during execution of work (₹ in crores)**

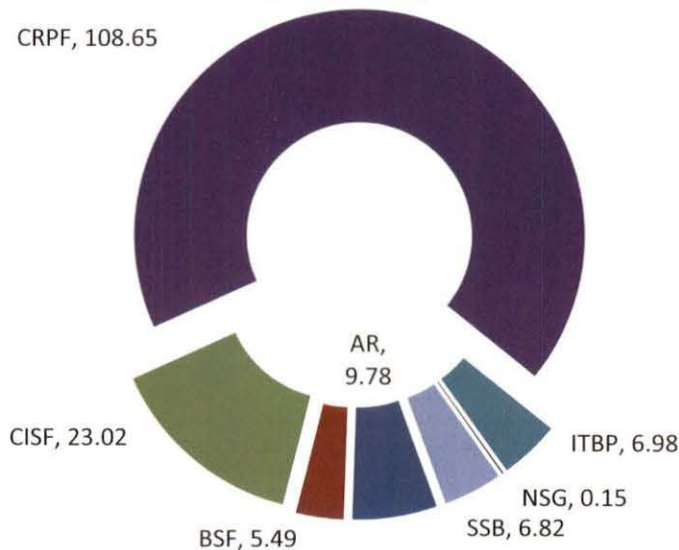

Financial irregularities were noticed mainly in the works of CRPF (67 per cent) and CISF (14 per cent). Details of financial irregularities have been explained in Chapter-VII. In CRPF, audit noticed financial irregularities in mobilisation advances, non-recovery of liquidated damages, release of bank guarantee before adjustment of mobilisation advances, excess payments etc. This indicates a need for CAPFs to strengthen the mechanism of financial monitoring.

## 8.7 TAKING OVER OF INCOMPLETE WORKS

After completion of work, CAPFs were required to properly check the completed work and ensure that it has been done as per the specifications and requirements and fulfilled the purpose for which it was constructed. However, audit noticed instances of non-handing over of completed works or handing over of incomplete works by executing agencies to CAPFs as explained in para 4.5.7 of Chapter-IV. The force wise position for such works was as follows:

**Table-8.4: Force-wise details of taking over of incomplete works**

(₹ in crore)		
Name of force	Number of works	Sanctioned amount
AR	6	34.88
BSF	1	0.20
CRPF	4	43.73

A glaring example of a work having irregularities at every stage occurred in construction of quarters and hostels for Assam Rifles at Dwarka. Irregularities from narrative overleaf are explained at relevant portions in this chapter while the whole picture is depicted below:

### Case Study 8.1:

In May 2003, MHA sanctioned ₹ 4.50 crore for total 88 Type-II, III and IV quarters at Dwarka, New Delhi. AR split up the work in two parts and awarded one part viz. C/o 32 Nos Type-II, 16 Nos Type-III Quarters, 30 rooms for boys and 20 rooms for girls Hostels to EPIL in January 2004 for ₹4.81 crore which was revised to ₹ 16.85 crore. Later in 2009, AR awarded the remaining work of 32 Type II and 8 Type IV quarters to EPIL for ₹ 16.45 crore. Both works are still incomplete as of June 2015. The detailed chronology of events during the construction activities is depicted below:

Chart-8.6

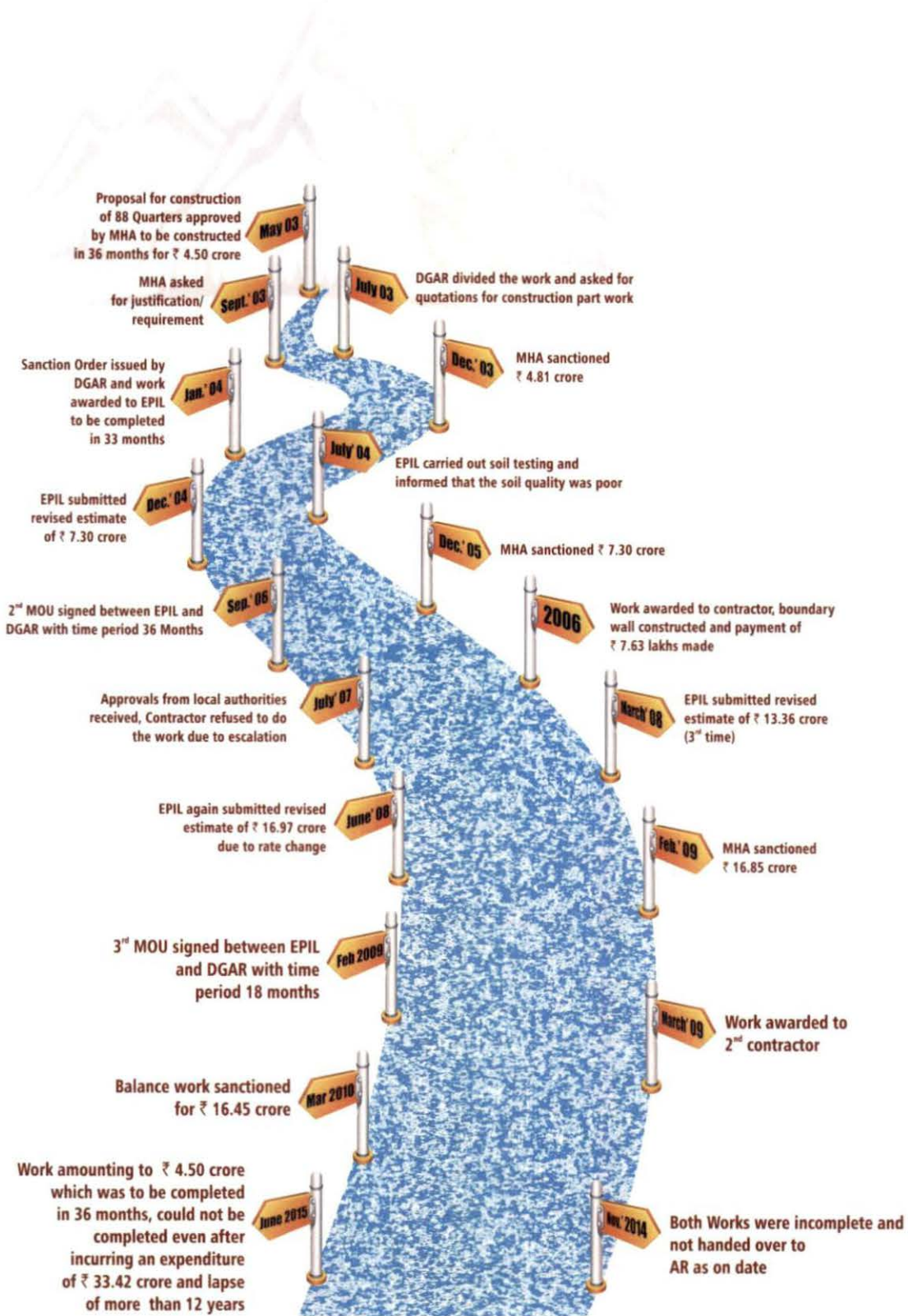

AR in its reply (June 2015) accepted the observation by stating that AR had only one liaison office in Delhi and its personnel are from different parts of the country, so for AR personnel it was decided to offset some accommodation authorisation from North East to Delhi and accordingly sanction was obtained from MHA. It stated that work was delayed due to various reasons as change in drawing of the building, delay in obtaining revised sanction from MHA, estimates increase due to increase in cost index. It further stated that delay in obtaining approvals from local authorities was due to procedural delay and for delay in execution part of the work, EPIL was responsible. Reply was not acceptable as construction of 88 quarters in Delhi was not justified as mandate for operational area of AR was in North East India and not Delhi. Work was delayed not only due to executing agency (EPIL) but also due to poor monitoring of the work by AR.

Thus, the original work which was estimated at ₹ 4.50 crore in May 2003 with stipulated date of completion of 36 months is still under construction, (June 2015) i.e., after a lapse of more than 12 years after incurring an expenditure of ₹ 33.42 crore and with cost escalation of 643 per cent.

## 8.8 UTILISATION OF CONSTRUCTED BUILDINGS

As the basic purpose of construction of a building is to utilize it for the intended purpose, it is very important to ensure that building was put to the pre-defined use. However, audit noticed instances where the constructed buildings were not utilized fully as explained in para 6.3.2 of Chapter-VI. The total sanctioned amount for construction not used for intended purpose by the forces was as detailed below:

**Table-8.5: Force-wise details of utilization of constructed buildings**

(₹ in crore)

Name of force	Sanctioned amount
AR	18.19
CRPF	7.08
SSB	2.18
<b>Total</b>	<b>27.45</b>

The maximum such cases were found in AR and no such cases were found in BSF, ITBP and CISF and NSG.

## 8.9 MAINTENANCE OF RESOURCES

Earlier all the construction works of CAPFs were executed by the CPWD, so maintenance of all office/residential building was the responsibility of the CPWD. But the works executed by PWOs viz. NBCC, EPIL, NPCCL, HPL etc. for CAPFs were not being maintained by them as no provisions for maintenance of building was incorporated

in their MoUs. CPWD was not ready to maintain these buildings on the plea that these buildings were not constructed by them and PWOs were demanding exorbitant charges for maintenance i.e. up to 20 *per cent* as agency charges of the estimated cost of maintenance. As maintenance charges of PWOs were on higher side, CAPFs were not ready to award maintenance contract to these PWOs due to paucity of funds. It has resulted in non-maintenance / poor maintenance of the assets of CAPFs created by these PWOs.

During joint physical inspection, audit noticed several deficiencies in the work of C/o 3 numbers 240 men barrack for CISF campus at SSG Greater Noida & C/o 108 residential quarters for CISF campus at SSG Greater Noida which reflects poor maintenance of office/residential buildings. NBCC intimated the problems noticed during the joint physical inspection were mainly due to the non-maintenance of the buildings. These barracks were constructed two years before and no proper maintenance was done by CISF.

## 8.10 CONCLUSION

It was evident in audit that undue delays in submission of PEs by the executing agencies which were not monitored by CAPFs, and resulted in change in scope of work at later stages. Delay in granting of AA & ES by MHA / CAPFs had a cascading effect on the whole project, rendering AA&ES irrelevant in many cases. Works were split up by CAPFs to avoid taking sanction of the higher authorities.

About 50 *per cent* of the works could not be completed on time in CAPFs. It indicated poor monitoring of the projects by the CAPFs and not pushing the timelines effectively with the executing agencies. Further, nearly 16 *per cent* works which were completed after due date were executed by CAPFs themselves. Financial irregularities were also noticed in all CAPFs especially in CRPF and CISF which indicated a need for CAPFs to strengthen the mechanism of financial monitoring. CAPFs took over incomplete works which resulted in additional financial liability and inconvenience to jawans. Instances were noticed where newly constructed buildings were not put to use for the intended purpose.



## CHAPTER – IX

## Conclusion

CAPFs play an important role in safeguarding the borders and maintaining internal security. The shortcomings in providing proper office buildings and working environment hamper the working of these forces. The provision of housing facilities to CAPF personnel has an important bearing on the morale of the force as they work for long hours in far flung areas and under extreme weather conditions.

It was seen that the requirements of the forces, both for office and residential accommodation, were not addressed properly. There was a large gap in requirement and availability of office buildings of CAPFs during the period 2008-09 to 2013-14. Audit found that the satisfaction level in providing residential accommodation for other ranks in CAPFs was low, ranging between 3 *per cent* to 22 *per cent* as on March 2014 as against the prescribed satisfaction level of 25 *per cent*. Construction activities, starting from land acquisition were marred by numerous problems. In land acquisitions, CAPFs failed to adhere to the time limit prescribed by MHA mainly due to their failures in identification of land, obtaining AA/ES, delay in depositing the cost of land with state governments etc., CAPFs did not pursue the matter with state governments for speedy completion of land acquisition process resulting in delays. Further, there was absence of any planned interaction between higher authorities of CAPFs/MHA and state revenue departments for sorting out issues causing abnormal delay in acquisition of land.

Selection of executing agency for construction works was not based on any criteria, thus excluding the benefits of competition amongst the executing agencies which could accrue to the CAPFs. Audit found that Assam Rifles awarded the works on lump sum basis without preparing any detailed estimates, violating the GFR and MHA orders. Audit found that CAPFs/PWOs failed to finalise preliminary drawings with complete scope and specification in a reasonable time frame. This increased the estimated cost of works and delayed the execution. Many estimates prepared by PWOs were higher leading to overpayments or undue benefit to contractor. PWOs did not prepare realistic and firm estimates supported with detailed plans, drawings and specifications leading to huge deviations at the time of execution of work. Failure of CAPFs/PWOs in handing over



encumbrance free site, frequent changes in layout plan, drawings and designs resulted in delayed completion of work in most of the cases. PWOs also failed to ensure documentation of requisite data for proper delay analysis and benefitted the contractors by not imposing liquidated damages as per contract clauses. Proper monitoring mechanisms were not put in place by CAPFs/PWOs to adhere to contractual provisions resulting in inadmissible/excess payments.

Audit examination revealed lapses in quality assurance measures as there was no system of inspection by quality assurance wing of the CPWD and it was observed that PWOs did not have a quality assurance wing. Instances of non-testing of material and water by the executing agencies were also noticed during audit. There was no provision of third party inspection and quality assurance in the MoU/Agreement between CPWD/PWOs and the client CAPFs, due to which third party monitoring was altogether absent in all works of CAPFs. Audit also found cases where CAPFs failed to ensure utilisation of created assets for intended purpose. After taking over buildings, maintenance is essential for their proper up-keep and durability. Regular and systematic maintenance schedules (routine, annual, special, periodic etc.) enhance and durability of assets and the quality of working environment. During site visits, audit noticed poor maintenance of government buildings, barracks and residential accommodations of jawans, since maintenance procedures were missing or severely compromised.

Awarding the works to PWOs other than CPWD on payment of agency charges did not show any added advantage as delays and cost overruns persisted in the works executed by PWOs other than CPWD as well. Audit carried out comparative analysis of the working of executing agencies which showed that agencies were at par when compared on different parameters. Delays, deviations and cost overruns were noticed in the works executed by all the agencies, while CPWD showed the highest cases of aberrations. This is probably due to the fact that CAPFs did not have any well-defined inspection policy for monitoring the construction activities. No inspection was carried out by the higher authorities and where inspection was carried out by the officers of CAPFs, no inspection note was issued in respect of assessment carried out by them. No web based project monitoring system existed in PWOs due to which CAPFs did not have access to instant updates on construction activities. CAPFs did not monitor the ongoing works resulting in execution of sub-standard works in many cases. Though MHA monitors the progress of construction works of CAPFs by taking quarterly meetings of the officers of CAPFs and executing agencies, fruitful results were not noticed as the projects were still delayed and

cost overruns in the projects were rampant. The near absence of supervision of works by the CAPFs did not reflect an inspiring state of affairs, and the absence of an engineering wing was not a valid excuse. Overall, the required coordination and sense of mutual engagement between the MHA, the CAPFs and the executing agencies was found missing.

New Delhi  
Dated: 17 November 2015



(MUKESH PRASAD SINGH)  
Director General of Audit  
Central Expenditure

Countersigned



New Delhi  
Dated: 23 November 2015

(SHASHI KANT SHARMA)  
Comptroller and Auditor General of India

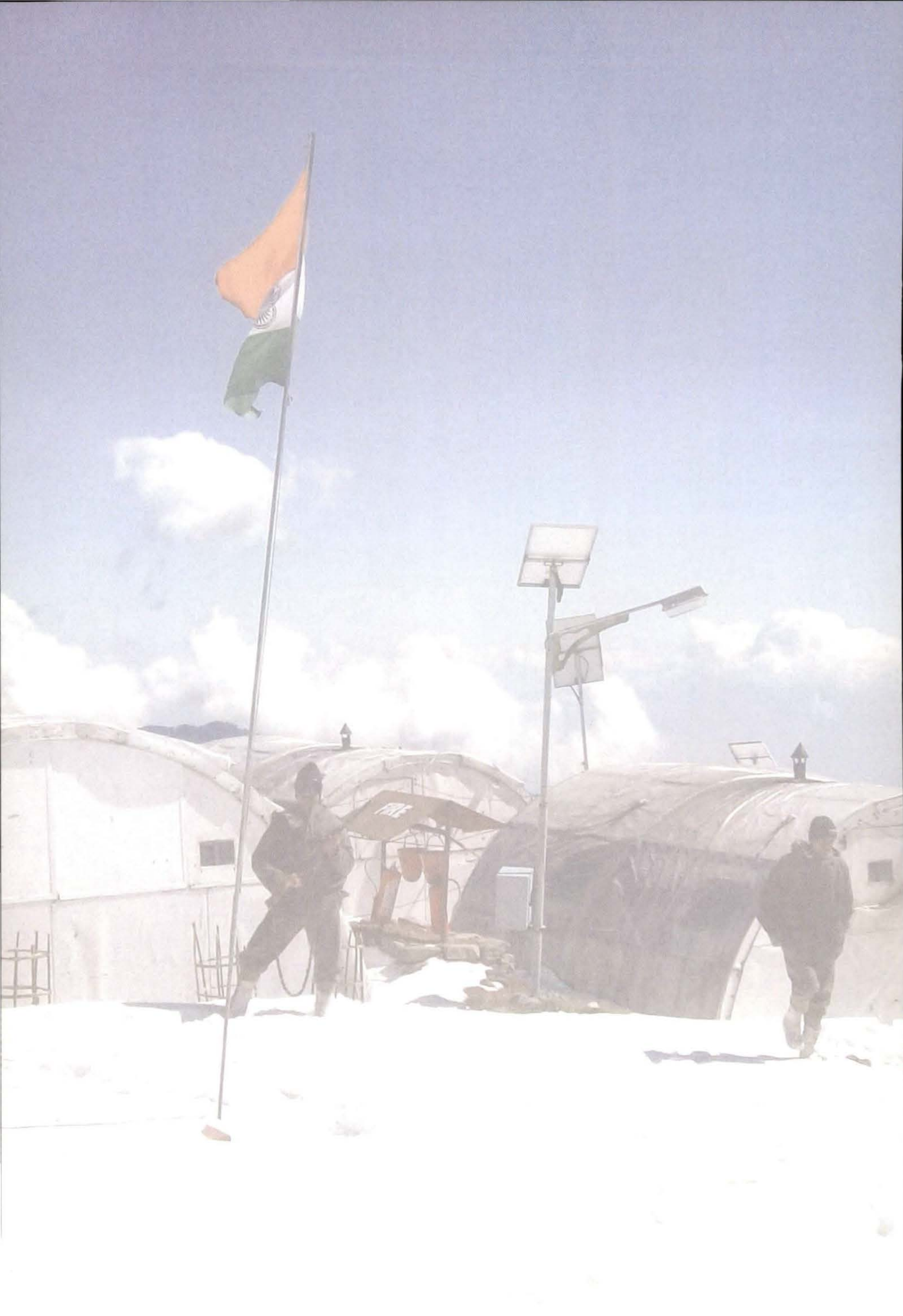

# **ANNEXES**



BOS MESS  
SHQ BSF JAMMU

**Annex-1.1**  
**Force-wise budget and expenditure under Major Works during 2008-09 to 2013-14**  
**(Refer para 1.3 & 2.3)**

(₹ in crore)

Details of Budget and Expenditure for Major Works (Capital Section)														
	2008-09		2009-10		2010-11		2011-12		2012-13		2013-14		Total	
	RE	Exp	RE	Exp	RE	Exp	RE	Exp	RE	Exp	RE	Exp	RE	Exp
AR	287.5	285.13	335.1	137.98	345.94	344.4	387.23	387.08	464.94	459.2	400	399.98	2220.71	2013.77
BSF	298.85	298.49	280.35	297.73	425.93	403.71	550.35	553.06	585	615.33	440.37	429.36	2580.85	2597.68
CISF	34.55	40.93	47.78	41.78	192	129.24	122	155.84	182.2	170.04	100.08	100.01	678.61	637.84
CRPF	205.1	231.29	297	261.21	454.07	453.33	754.82	750.49	1038.65	1057.11	792.29	729.50	3541.93	3482.93
ITBP	160.13	135.93	167.76	135.53	168	164.12	196.09	185.76	401	411.65	305.72	293.13	1398.70	1326.12
NSG	8.9	9.28	115.6	100.79	112.6	114.14	80.9	76.84	48.7	43.39	41.24	41.92	407.94	386.36
SSB	150.41	141.57	167.37	114.75	187	200.34	324.09	323.15	552.44	586.56	273.65	232.83	1654.96	1599.20
<b>Total</b>	<b>1145.44</b>	<b>1142.62</b>	<b>1410.96</b>	<b>1089.77</b>	<b>1885.54</b>	<b>1809.28</b>	<b>2415.48</b>	<b>2432.22</b>	<b>3272.93</b>	<b>3343.28</b>	<b>2353.35</b>	<b>2226.73</b>	<b>12483.7</b>	<b>12043.9</b>

**Annex-1.2**  
**List of 132 land acquisition cases and cases of delay in land acquisition**  
**(Refer para 1.8& 3.1)**

\* Para 1.8: 132 land acquisition cases

\*\*Para 3.1: S.No 1 to 87 represents cases of delay in land acquisition

(₹ in lakh)

Sl. No.	State	Force	Purpose of land acquired	Area	Cost of land	Date of approval of KLP	Date of deposit of money	Date of taking over of land	Months from KLP to Deposit Money	Months from Deposit money to possession	Total months from initiations
1.	Meghalaya	BSF	Acquisition of land for establishment of border out post (Sonatala)	7.04	24.89	4-Dec	13-Jan	13-May	96	3	99
2.	Meghalaya	BSF	Acquisition of land for establishment of border out post (Nongjuri)	1.99	36.62	4-Dec	11-Sep	13-Mar	80	17	97
3.	Assam	BSF	Acquisition of land for establishment of Platoon level border out post	2.83	4.69	10-Apr	14-Mar	14-Aug	46	4	50
4.	Tripura	BSF	Acquisition of land for establishment of BSF Bn. HQ at Kumarghat	58.77	61.49	4-Dec	11-Aug	12-Aug	79	11	90
5.	Assam	AR	Acquisition of land for establishment of Assam Rifles battalion KLP.	149	708.76	6-Mar	11-Sep	13-Dec	65	24	89
6.	Tripura	BSF	Acquisition of land for establishment of border out post BhairaBn.agar Das Para to minimize inter border out post distance and better domination of bordering area.	4	13.97	4-Dec	9-Jun	11-Jul	53	24	77
7.	Sikkim	SSB	Acquisition of land for establishment of border out post at Lingam	2.47	14.03	7-Jan	13-Feb	13-May	72	2	74
8.	Tripura	BSF	Acquisition of land for establishment of border out post Boxanagar to minimize inter border out post distance and better domination of bordering area.	3	32.52	4-Dec	9-Jun	11-Jan	53	18	71
9.	Sikkim	SSB	Acquisition of land for establishment of Coy level border out post at Padamchen	2.47	18.19	7-Jan	12-Jul	12-Sep	65	1	66

10.	Uttar Pradesh	SSB	Acquisition of land for establishment of Reserve Bn. HQ & Balance components of Ftr. HQ at Lucknow	43.29	5284.04	5-Jul	9-Jun	14-Mar	46	63	109
11.	Tripura	BSF	Acquisition of land for establishment of border out post Chittabari to minimize inter border out post distance and better domination of bordering area.	4	13.86	4-Dec	9-Sep	10-Apr	56	6	62
12.	Tripura	BSF	Acquisition of land for establishment of border out post Sabroom to minimize inter border out post distance and better domination of bordering area.	1.54	7.39	4-Dec	9-Aug	9-Dec	55	3	58
13.	Assam	ITBP	Acquisition of land for Sector HQ	74.12	117.63	7-Feb	9-Dec	11-Oct	33	21	54
14.	Mizoram	BSF	Acquisition of land for establishment of Bn. HQR at Seiling, Aizawl-I (M&C Ftr.)	88	1956.26	4-Dec	9-Aug	9-Sep	55	0	55
15.	Assam	ITBP	Acquisition of land for Sector HQ Tejpur Assam	15	35.46	7-Feb	9-Dec	11-Oct	33	21	54
16.	Tripura	BSF	Acquisition of land for establishment of border out post Dyke-VIII to minimize inter border out post distance and better domination of bordering area.	2.4	7.43	4-Dec	8-Nov	9-Mar	46	3	49
17.	Assam	SSB	Acquisition of land for establishment of Platoon level border out post at Nonaikuti under 37 the Bn. SSB Mangaldoi	2.87	8.68	9-Nov	12-Jun	12-Dec	30	5	35
18.	Uttar Pradesh	BSF	Acquisition of land for establishment of Bn. HQ at Lucknow	65.34	298.58	4-Dec	8-Feb	11-Jan	37	43	80
19.	Bihar	SSB	Additional sanction for acquisition of land measuring 3 acres for establishment of border out post HQ. Musachak under Bn. HQ Sitamarhi of Ftr. HQ. Patna	3	58.03	7-Jan	9-Feb	12-Aug	24	43	67
20.	Tripura	BSF	Acquisition of land for establishment of border out post Acharjee para to minimize inter border out post distance and better domination of bordering area.	1.18	4.16	4-Dec	8-Aug		43		43
21.	Assam	BSF	Acquisition of land for establishment of company level border out post of 162 Bn. BSF under Sector HQ BSF Dhubri (Guwahati Ftr.)	6.48	21.54	10-Apr	13-Dec		43		43



22.	Assam	BSF	Acquisition of land for establishment of company level border out post of 162 Bn. BSF	2.6	12.21	10-Apr	13-Dec		43		43
23.	Assam	CISF	Acquisition of land for establishment of CISF 9th Reserve Bn. at Guwahati	99.17	90.47	9-Mar	12-May		37		37
24.	West Bengal	BSF	Acquisition of land for establishment of border out post-Raidighi under Sector HQ Raiganj (NB Ftr.)	3.08	17.2		10-Jul	13-Sep		37	37
25.	Assam	BSF	Acquisition of land for establishment of Bn. HQ, for DM Bn. (128 Bn. BSF)	33.06	375	4-Nov	7-Aug		32		32
26.	West Bengal	SSB	Acquisition of land for Bn. HQ at Malbazar	65.31	244.78		8-Dec	11-Apr		27	27
27.	Bihar	SSB	Acquisition of land for border out post HQ Teenlalten under Bn. HQ. Narkatiaganj (Bihar)	3	27.33	7-Jan	10-Nov	12-Nov	45	23	68
28.	Uttar Pradesh	SSB	Acquisition of land for establishment of Sector HQ And Bn. HQ At Lakhimpur Khri	80.88	1566.74	5-Jul	8-Sep	10-Jul	37	21	58
29.	Bihar	SSB	Acquisition of additional land measuring 2.50 acres in respect of Coy-cum-border out post hqr Sikta under 27th Bn.Narkatiaganj	5	34.77	7-Jan	10-Apr	12-Feb	38	21	59
30.	Uttra Khand	SSB	Acquisition of land for establishment of border out post HQ Jhulaghat	1.5	41.87	5-Aug	11-Aug	13-May	71	20	91
31.	Uttar Pradesh	ITBP	Acquisition of land for establishment of Battalion HQ at Kanpur	69.5	1091.34	8-Aug	9-Mar	10-Dec	6	19	25
32.	Assam	SSB	For establishment of Coy HQRat Nalaparaand Coy border out post at Tankibasti under 37 the Bn. SSB Mangaldoi	7.27	22		9-Mar	10-Oct		18	18
33.	Bihar	SSB	Revalidation sanction of 1 Lac for acquisition of 2.50 acres addl. Land for estt. of Coy HQ Sonbaa under 9th Bn. HQR (Now 20th Bn..Sitamarhi)	5	36.84	7-Jan	11-Apr	12-Aug	50	15	65
34.	Bihar	SSB	Additional sanction for acquisition of 3.00 acre land for establishment of border out post HQ Yadavtola under Bn. HQ Thakurganj	3	14.12	7-Jan	12-Nov	14-Jan	69	13	82
35.	Uttar Pradesh	SSB	Acquisition of land for establishment of border out post, Nazulia	1.26	7.37	3-Dec	9-Feb	10-Mar	61	12	73

36.	Uttar Pradesh	CRPF	Acquisition of land for establishment of Camping site of Bn. Allahabad	1.37	137.21	9-Dec	11-Dec	12-Jun	23	10	33
37.	Bihar	SSB	Regarding sanction of additional amount for acquisition of land measuring 75 acre for 27th Bn. HQ. at Narkatiaganj	74.34	1237.94	5-Feb	6-Sep	7-Jun	18	8	26
38.	Uttra Khand	SSB	Acquisition of land for establishment of border out post HQr Khaldhunga-I	1.25	5.17		5-Sep	6-May		7	7
39.	West Bengal	SSB	Acquisition of land for establishment of border out post HQ. Lamyadhura and Phool Khola under 29th Bn. HQ. SSB Kahprail.	3.75	18.52		10-Apr	10-Oct		5	5
40.	Assam	SSB	Acquisition of land for establishment of Training Centre	3.31	3.95		10-Sep	11-Mar		5	5
41.	Uttar Pradesh	CRPF	Acquisition of land for establishment of Group Centre & Ranj HQ at Trisundi Amethi	264.73	3110.22	6-Oct	9-Nov	10-Mar	36	4	40
42.	Uttra Khand	SSB	Acquisition of land for establishment of border out post-Ghola	0.86	NA	5-Jul	11-Apr	11-Sep	68	4	72
43.	Uttra Khand	BSF	Acquisition of land for establishment of AI Rol Bn. Deharadun	20.09	236	4-Dec	11-May	11-May	77	0	77
44.	Uttra Khand	SSB	Acquisition of land for establishment of Coy-cum-border out post Basai	2.47	not finalised	2-Sep	12-May	12-Jul	115	1	116
45.	Uttar Pradesh	CISF	For establishing CISF Group HQrs Allahabad	4	1450.1	8-Feb	10-Aug	11-Mar	29	6	35
46.	Uttra Khand	SSB	Acquisition of land for establishment of Bn. HQ. Deharadun	26.2	413.66	10-Aug	13-Jul	13-Aug	34	0	34
47.	Uttra Khand	SSB	Acquisition of land for establishment of border out post-Simbalghat	2.35	not finalised	10-Jun	12-May	12-Jun	22	0	22
48.	Bihar	SSB	Additional sanction for acquisition of land measuring 3.96 acres for establishment of Coy cum border out post HQ Lalbandi under Bn. HQ. Sitamarhi	3.96	57.99	7-Jan	11-Oct	12-Sep	56	10	66
49.	Bihar	SSB	Additional sanction for acquisition of additional land measuring 1.61 acres against 1.75 acres sanctioned initially for establishment of border out post HQ Siiya under Bn. HQ Sitamarhi-II	2.86	23.4	7-Jan	9-Aug	12-Sep	30	0	30

50.	Bihar	SSB	Additional sanction for acquisition of land measuring 03 acres for establishment of border out post HQ Basantapur under Bn. HQ Narkatiaganj	3	32.49	7-Jan	9-Jul	10-Sep	29	13	42
51.	Tripura	BSF	Acquisition of land for establishment of border out post Konaban to minimize inter border out post distance and better domination of bordering area.	3	10.38	4-Dec	9-Apr	10-Feb	51	9	60
52.	Sikkim	SSB	Acquisition of land for establishment of Bn. HQ at Yangtey, Geyging	64	1467.33	Feb 12 (Revised)	11-Feb	12-Apr		13	13
53.	Arunachal Pradesh	SSB	For establishment of 61st Bn. HQ Twang-II	31.79	383.31		13-Jun				0
54.	Rajasthan	BSF	Acquisition of 70 acres land for Bn. HQ at Baramsar, Ramgarh Rajasthan Ftr.	70	29.67						
55.	Rajasthan	SSB	Acquisition of land measuring 229.04 acres (110.85 acres in village Mauzur Tehsil Laxmangarh and 118.19 acres in village Dera Tehsil Rajgarh for establishment of two Reserve Bn. Hwr One Sector HQ and SSB Dog Training-cum-Breeding Centre in District Alwar (Rajasthan)	229.04	827						
56.	Rajasthan	CRPF	Purchase of Rajputna Hotel Estate (RHE) building/land for ISA Mount Abu	5.18	1850						
57.	West Bengal	BSF	Acquisition of land for establishment of border out post Chandrapara	2.96	6.02	Land not acquired					
58.	West Bengal	SSB	Acquisition of land for establishment of Reserve Bn. HQ. Sambalpur	60.79	1,297.52	Land not acquired					
59.	Mizoram	AR	Acquisition 115.52 acres land for 1xBattalion KLP at Lungtlai (Mizoram)	115.52	163.63	Land not acquired					
60.	Gujarat	BSF	Acquisition of 77.19 Acres land for Marine Bn. HQ at Sedata Bhuj (Gujarat Ftr.)	77.19	624.77	Land not acquired					
61.	Bihar	SSB	Acquisition of lands for establishment of border out post HQ. at Mazrakh under 28th Bn. Araria	3	29.52	Land not acquired					

62.	Bihar	SSB	Acquisition of additional land measuring 1.75 acre for establishment of border out post HQ. at Kamala under 14th Bn. Jaynagar	1.75	19.45	Land not acquired
63.	Bihar	SSB	Acquisition of additional land measuring 02 acre of land for establishment of Coy-cum-border out post HQ. at Kamla under 14th Bn. Jaynagar	2	26.89	Land not acquired
64.	Bihar	SSB	Acquisition of land for establishment of border out post Tarabari under 36th Bn. Thakurganj	3	8.61	Land not acquired
65.	Bihar	SSB	Acquisition of land measuring 3.00 acres in respect of border out post HQ. at Kelabari under 28th Bn. Araria	3	72.29	Land not acquired
66.	Bihar	SSB	Acquisition of land measuring 73 acres for establishment of Reserve Bn. and Ftr. HQ. Patna at Didarganj Rail over bridge	73	3,728.41	Land not acquired
67.	Uttra Khand	SSB	Acquisition of land for establishment of border out post HQ. Lamari	0.32	0.06	Land not acquired
68.	Uttra Khand	SSB	Acquisition of land for establishment of border out post HQ. Quitar	3.169	15.15	Land not acquired
69.	Bihar	SSB	Acquisition of 1.25 acre land for border out post HQ Amgachi under Bn. HQ. Bathnaha, Bihar.	3	2.64	Land not acquired
70.	Bihar	SSB	Acquisition of land measuring 3 acres for establishment border out post HQ. Khaalwa under Bn. HQ. Sitamarhi-I.	3	68.53	Land not acquired
71.	Bihar	SSB	Acquisition of land measuring 3 acres for establishment border out post HQ Berihari under Bn. HQ. Piprakothi (Ramgarhwa)	3	82.81	Land not acquired
72.	Bihar	SSB	Acquisition of land measuring 3acres for establishment border out post HQ. Dinmatola under Bn. HQ Sitamarhi-II.	3	70.2	Land not acquired
73.	Bihar	SSB	Acquisition of land measuring 3acres for establishment border out post HQ. Nawahi under Bn. HQ. Sitamarhi-II.	3	159.55	Land not acquired

74.	Bihar	SSB	Acquisition of land measuring 3 acres for establishment border out post HQ. Dhalkawa under Bn. HQ. Sitamarhi-II.	3	57.44	Land not acquired
75.	Bihar	SSB	Acquisition of land measuring 3 acres for establishment border out post HQ Koraiya (New) under Bn. HQ. Motihari	3	116.76	Land not acquired
76.	Uttar Pradesh	SSB	Acquisition of land for establishment of border out post HQ Kapishwa under Bn. HQ Sidharth Nagar	3	112.46	Land not acquired
77.	Bihar	SSB	Additional sanction for acquisition of 85 acres of land for Bn. HQ Kishan Ganj, Bihar	75	1,850.98	Land not acquired
78.	Bihar	SSB	Acquisition of land measuring 40.77 acres for establishment of Reserve Bn. HQ SSB Patna.	40.77	2,739.82	Land not acquired
79.	Uttar Pradesh	SSB	Acquisition of land for establishment of border out post HQ Chirigawan under Bn. HQ Sidharth Nagar	3	112.48	Land not acquired
80.	Uttar Pradesh	SSB	Acquisition of land for establishment of Company HQ border out post at Sonuli under Bn. HQ SSB Mahrajganj	2.21	51.14	Land not acquired
81.	Bihar	SSB	Acquisition of land for border out post Kanta under 27th Bn. Narkatiaganj, Bihar	3	22.95	Land not acquired
82.	Bihar	SSB	Additional cost sanction for land in respect of border out post HQ Dumarbana under 24th Bn. HQ SSB Bathnaha.	1.75	7.29	Land not acquired
83.	West Bengal	SSB	Acquisition of land for establishment of Bn. HQ at Khaprail	74.49	804.28	Land not acquired
84.	GOA	CISF	Acquisition of 70 acres land for 6 <sup>th</sup> Reserve Bn. CISF at village Pernem, North Goa	100	555.47	Land not acquired
85.	Maharashtra	BSF	Acquisition of land for Reserve Bn. at Takali District-Sholapur for an areas of 32.29 Hectors (77.79 acres)	77.79	1,000.50	Land not acquired
86.	Telangana	BSF	Acquisition of land for establishment of reserve Bn. Of BSF in Telangana	84.33	847.98	Land not acquired

87.	West Bengal	BSF	Acquisition of land for establishment of Bn. HQ at Roshanbagh	43.53	128.91	Land not acquired				
88.	Manipur	AR	Acquisition of 150 acre of land for Bn at Modi, Manipur.		92.5					
89.	Nagaland	AR	Acquisition of 75 acres land for office of IG, AR at Chakbama, Nagaland		264.15					
90.	Manipur	AR	Acquisition of 13.051 acres land for Bn at Shangshak (on court).		30.54					
91.	Rajasthan	BSF	Acquisition of 9500 Acres land for Firing range at Kishangarh, Ramgarh (Rajasthan Ftr.)		195.29					
92.	Rajasthan	BSF.	Acquisition of 6.5 Acres land for border out post- Deepawala (Rajasthan Ftr.)		Not finalized					
93.	Gujarat	BSF	Acquisition of 5.00 Acres land for marine border out post Akri (Gujarat Ftr.)		42.73					
94.	Gujarat	BSF	Acquisition of 3.00 Acres land for border out post - Ashira Wand under Sector HQ BSF Bhuj (Guj Ftr.)		28.81					
95.	Maharashtra	BSF	Acquisition of 80 Acres land for establishment of Bn. HQ at Varsagaon, Distt- Pune Maharashtra		5.31					
96.	Odisha	BSF	Acquisition of land for Bn. HQ BSF Odisha.							
97.	Tripura	BSF	Hiring of Hanger for BSF Helicopter at Agartala Airport		Land was not acquired but hired.					
98.	Tripura	BSF	Acquisition of land for establishment of border out post Yaku Bn. at Agartala to minimize inter-border out post distance and better domination of bordering area.		40.1					
99.	Punjab	BSF	Implementation of court order in respect of 49 acres 04 Kanal 18 Marla land at Village-Sohana, Lakhnour Chandigarh Punjab for Bn. HQ							

100.	Jammu & Kashmir	BSF	Acquisition of 44 kanal & 17 marla land for border out post-Bobiya under Sector HQ Indreshwar Nagar (Jammu Ftr.)								
101.	Jammu & Kashmir	BSF	Acquisition of 46 kanal, 14 marla land for border out post 6R under Sector HQ Indreshwar Nagar Jammu								
102.	Rajasthan	CISF	Acquisition of 35.60 hectare land for Firing range of CISF Madhya Pradesh Regional Training Centre Behror, Distt Alwar		188.04						
103.	Tamilnadu	CISF	Acquisition of land for residential & non-residential. building for 4th RB at Amaravathi, Pudur, Karaikuri, Sivagangai		1003						
104.	Karnataka	CISF	Acquisition of land for establishment of 10 <sup>th</sup> reserve Bn.		1834.25						
105.	Gujarat	CRPF	Acquisition of 0.5 acre of land for Martyrs memorial at Rann of Kutch, Gujarat		0.08						
106.	Jharkhand	CRPF	Acquisition of land for establishment of Group Centre CRPF in Jharkhand		86.29						
107.	Jharkhand	CRPF	Acquisition of land for establishment of CRPF Bn. In Jharkhand		0						
108.	Madhya Pradesh	CRPF	Acquisition of 81.06 acre of land for 208 COBRA Bn. at Balaghat, Madhya Pradesh		1						
109.	Karnataka	CRPF	Acquisition of land for establishment of Modern Field firing range in Karnataka		81.4						
110.	West Bengal	CRPF	Acquisition of land for establishment of 207 CRPF COBRA Bn. at Salboni		0						
111.	Nagaland	CRPF	Acquisition of 25.5 acre of land for Bn. site at Mokokchung, Nagaland		4.34						
112.	West Bengal	CRPF	Acquisition of land for establishment of Battalion Camp Medinipur		188						
113.	Jammu & Kashmir	CRPF	Acquisition of 4.75 acre of land for Bn. Site at Agling Tang Spituk, Leh, Jammu & Kashmir								
114.	Jammu & Kashmir	CRPF	Acquisition of 3.9 acre of land for transit camp Ramnagar near Samba Railway Station, Jammu		18.19						

115.	Tamilnadu	ITBP	Acquisition of land for establishment of Bn. HQrs , Madurai	80						
116.	Tamilnadu	ITBP	Acquisition of land for establishment of Regional Training Centre at Sivagangai	Not finalized						
117.	Odisha	ITBP	Acquisition of land for establishment of Bn. & Sector HQ							
118.	Karnataka	ITBP	Acquisition of land for establishment of Bn. and Development Center	0						
119.	Jammu & Kashmir	ITBP	Acquisition of 48.25 acre government land for Bn. HQ at Samba, Jammu & Kashmir	386						
120.	Delhi	NSG	Acquisition of land for establishment of Regional Hub of NSG in Delhi	29.45						
121.	Maharashtra	NSG	Acquisition of land for establishment of regional hub at Marol, Thungvey, Mumbai, 23 acres (Actually in possession of NSG 20.28 acres)	0						
122.	West Bengal	NSG	Acquisition of land for establishment of Regional Centre at Rajarhat, Kolkata on Lease	3547.5						
123.	Delhi	SSB	Acquisition of land for establishment of Force HQ SSB in New Delhi	57.59						
124.	Uttra Khand	SSB	Acquisition of land for establishment of SSB Academy at Srinagar (Garhwal)	33.34						
125.	Bihar	SSB	Acquisition of land for establishment of border out post HQ at Mazrakh under 28th Bn. Araria	Not finalized						
126.	Bihar	SSB	Sanction of additional amount for acquisition of lands in respect of (i) comany Kanwa (ii) comany Majorganj (iii) border out post Dhararwa (iv) border out post Srikhandbhitta (Bhittamore) (v) border out post Basbitta (Belwapari) under 09th Battalion Sitamarhi (Bihar).	156.03						
127.	Bihar	SSB	Acquisition of and measuring 1.729 acres for establishment of border out post Soniatl under Bn. HQ Maharajganj							



128.	Bihar	SSB	Acquisition of and measuring 3 acres for establishment of border out post HQ Karmiswa under Bn. HQ. Maharajganj								
129.	Bihar	SSB	Acquisition of land measuring 3 acres for establishment of border out post Laxmipur under Bn. HQ Maharajganj								
130.	West Bengal	SSB	Acquisition of land for establishment of Group Centre HQ at Karnajora		144.72						
131.	Assam	SSB	Acquisition of land for establishment of SSB border out post 33rd Bn. on International Bengla Desh Border		8.41						
132.	Assam	SSB	Acquisition of and for establishment of Platoon level border out post at Nonaikuti under 37th Bn. SSB Mangaldoi, Assam		8.68						

## Annex-1.3

**List of 710 works cases which including delay in submission of PE, AA&ES and award of work  
(Refer para 1.8, 4.1.3, 4.1.5, 4.1.6, 4.2.2, 4.3.1, 4.5.2, 4.5.3, 4.5.4 and 7.5)**

- Colour coding
  - Violet- 341 Cases of delay in approval from local authorities (Para 4.1.3)
  - Blue- 173 Cases of delay in months taken by the PWO in subMission of PE (Para 4.1.6)
  - Red- 197 Cases of delay in getting administration approval (Para 4.2.2)
  - Yellow- 240 Cases of delay in awarding the contract by PWO (Para 4.3.1)
  - Green- 111 Cases of provision for water harvesting not made in PE (Para:4.15)
  - Peach – 305 Cases of extra items (Para:4.5.3)
  - Black&White- 132 Cases of substituted items (Para:4.5.4)
  - Sky blue- 241 Cases of deviated items (Para:4.5.2)
  - Orange – 112 Cases of labour cess (Para:7.5)
  - List of 710 Cases of Construction works (Para:1.8)

(₹ in lakh)

S.No	Name of the Force	Name of the State	Particulars of the work	Name NEEEn Executin Eg Agency	Months taken by Agency in submission of the PE to the Force	Months taken by Force in giving AA & ES	Months taken by Agency in awarding the contract after AA & ES	Amount of the AA & ES	Number of extra items	Total amount of the extra items	Number of substituted items utilized in Work	Total amount of the substitute items	No of items where deviation was more than 30% against the BOQ (both above or less)	Percentage range of deviation	Total Amount of deviation	Non deduction of Labour Cess
1	BSF	West Bengal	Construction of Nalla and drain including deveopmen MT work adjacent to boundary wall in rear porition of Kadamtala	CPWD	3	15	0	98.42	2	8.38		0	4	(-)100 to 47	18.1	0
2	BSF	Assam	Construction of remaining portion of boundary wall for BSF campus at dholchera Silchar, Assam	CPWD	4	13	3	178.69	1	1.09		0	7	(-) 100 to 95	23.6	0
3	BSF	West Bengal	Construction of MT workshop & MT park for Sector HQ Siliguri at Radhabari under North East Ftr. BSF	CPWD	19	1	5	491.36	26	2.48		0	22	31 to 870	68.2	0
4	BSF	West Bengal	Construction of combined drill shed for 02 unit at BSF campus Raninagar, Jalpaiguri	CPWD	24	2	5	222.58	23	8.47	3	0.46	35	33 to 1883	17.3	0

5	BSF	West Bengal	Construction of magazine, kote,"A"Type jawan, barrack (2 nos.) at BPO-Srirampur	CPWD	0	1	6	74.55		0	0			0	0	
6	BSF	West Bengal	Construction of combined drill shed and open air theatre for Signal Training Centre, BSF,	CPWD	42	2	14	492.39	17	7.96	0	18	35 to 418	49.5	0	
7	BSF	Mizoram	Construction of SOs mess including development of site and bulk services at Bn.hq, BSF campus, Zotlang near Lunglei under Sector HQ BSF, Aizawl, Mizoram.	CPWD	5	1	9	200.26	3	1.06	0			0	0	
8	BSF	Tripura	Construction of mi room for Bn.HQ BSF campus Maharanchera under Sector HQ BSF	CPWD	7	28	4	149.54	33	16.57	0	65	(-) 100 to 4757	46.7	0	
9	BSF	Tripura	Construction of SOs mess with 4 nos. suits for BSF Bn.at Tripura	CPWD	9	3	6	145.09	39	18.11	0	67	(-) 100 to 2107	45.7	0	
10	BSF	Mizoram	Construction of Type-V, 1 no. quarter at BSF campus, Lunglei (Mizoram) under Ftr. HQ BSF, Aizawl, Mizoram	CPWD	6	1	24	76.56	1	0.28	0			0	0	
11	BSF	West Bengal	Construction of jawan barrack and magazine kote including internal water supply and sanitary intallation at border out post Khajipara in Nadia diatrick of West Bengal for 42 Bn. under Sector HQ, BSF Krishnanagar	CPWD	0	1	6	77.25	9	2.46	2	0.14	40	(-) 100 to 670	7.67	0
12	BSF	West Bengal	Construction of office block, magazine, Kote, wireless block & jawan barrack at border out post Durgapur of 28 Bn.BSF under Sector HQ Malda, HQ Malda Ftr. BSF.	CPWD	1	2	2	103.15	6	1.28	0	30	(-) 100 to 233	17.6	0	
13	BSF	West Bengal	Construction of kitchen, dining block, jawan barrack & toilet block at border out post	CPWD	#	Nil	4	61.26	13	0.64	0	12	37 to 835	8.77	0	
14	BSF	West Bengal	Construction of administration block magazine, kote, kitchen and dining hall including internal water supply and sanitary installation of border out post in Murshidabad District of West Bengal for 126 Bn. BSF under Sector HQ BSF Kolkata, South Bengal Ftr. BSF	CPWD	1	2	3	59.59	21	5.68	2	0.05	27	(-) 100 to 920	18.2	0
15	BSF	West Bengal	Construction of administration block magazine, Kote, Kitchen and Dining hall including internal water supply and sanitary installation of border out post Bhatupara in Nadia district of West Bengal for 92 Bn. BSF under Sector HQ BSF Krishna Nagar Ftr. BSF	CPWD	1	1	4	77.24	3	0.03	2	0.11	81	(-) 100 to 334	22	0
16	BSF	West Bengal	Construction of administration block magazine, Kote, Kitchen and Dining hall including in ternal water supply and sanitary installation of border out post Natna innadia district of West Bengal for 92 Bn. BSF under Sector HQ BSF Krishna Nagar Ftr. BSF	CPWD	0	1	4	77.25	7	8.1	4	0.21	27	39 to 2239	1.92	0
17	BSF	West Bengal	Construction of administration block magazine, kote, kitchen and dining hall including in ternal water supply and sanitary installation of border out post Maluapara in Nadia district of West Bengal for 42Bn. BSF under Sector HQ BSF Krishnanagar Ftr. BSF	CPWD	0	1	4	77.25	14	2.73	1	0.01	39	(-) 100 to 1688	5.81	0

18	BSF	West Bengal	Construction of jawan barrack & magazine Kote at border out post Chandichak of 151 Bn. BSF under Sector HQ BSF Berhampore, sb Ftr. BSF	CPWD	1	1	6	95.93								0	0			0	0
19	BSF	West Bengal	Construction of office block, magazine, Kote Wireless block, & jawan barrack at border out post Devipur of 57 Bn.BSF under Sector HQ Malda, HQ Malda Ftr. BSF.	CPWD	1	1	4	105.13								0	0			0	0
20	BSF	West Bengal	Construction of office block, magazine, Kote, wireless block & kitchen, dining block & toilet block at border out post Chakabanshi of 57 Bn.BSF under Sector HQ Malda, Malda Ftr. HQ BSF.	CPWD	1	2	4	90.07	11	0.15		0	45	(-) 100 to 260	6.98						0
21	BSF	West Bengal	Construction of magazine, kote, wireless block & kitchen, dining block & jawan barrack & toilet block at border out post Kestopur of 123 Bn. BSF under Sector HQ BSF Malda, Malda Ftr. HQ BSF	CPWD	2	4	8	92.72	9	0.75		0	51	(-)100 to 338	9.8						0
22	BSF	West Bengal	Construction of magazine, Kote, wireless block & jawan barrack at border out post Domutha of 69 Bn. BSF under Sector HQ Malda, Malda Ftr. HQ BSF.	CPWD	6	3	5	72.38	4	0.75		0	26	38 to 388	9.17						0
23	BSF	West Bengal	Construction of 06 nos. double storied pre- fab structures at Signal Training Centre BSF, North Bengal	NBCC	#!	#VALUE	4	289.13	3	2.8		0								0	0
24	BSF	West Bengal	Constructions of platoon level border out post at Shamsher near bp no. 215/4-s to 218/1-s in Malda district of West Bengal including internal electrical installation.	CPWD	19	7	8	495.2	4	2.64		0	3	42 to 136	1.19						0
25	BSF	Assam	Construction of RCC over Head Tank of 1.5 lac litres capacity, 3 lacs liters capacity U.G. Sump, boring of deep tube well, iron removal filtration plant and laying of water supply line from over head tank to existing line at BSF Campus Patgaon, Guwahati (Assam).	CPWD	7	1	0	182.66				0								0	0
26	BSF	Assam	Construction of 12 nos. Type -II residential quarters at Ftr. HQ BSF Guwahati location at Patagaon (Guwahati)	CPWD	3	5	4	218.03	2	4.05		0								0	0
27	BSF	West Bengal	Construction of residential quarters (SH: Type-V/02, Type-IV/08, & t/III/12 for Bn. HQ BSF at Khagra-III under Sector HQ BSF Kishanganj, HQ North Bengal Ftr. BSF	CPWD	1	7	17	488.38				0	0							0	0
28	BSF	West Bengal	Construction of one number 120 Men Barrack at Bn. HQR BSF Campus Assam.	CPWD	0	14	11	429.67				0	0							0	0
29	BSF	Meghalaya	Construction of GOs mess with 07 suites for Bn. HQ, Tura (New Location), Bewegre.	CPWD	9	2	12	334.04				0	0							0	0
30	BSF	Meghalaya	Construction of quarter Guard / Kote /Armoury workshop for Bn. HQ, Tura (New Location), Bewegre.	CPWD	9	2	6	296.47				0	0							0	0
31	BSF	Assam	Sanction for consturction of officer mess for HQ Guwahati Ftr. BSF campus Patgaon, Guwahati, Assam	CPWD	0	6	0	455.7				0	0							0	0

32	BSF	West Bengal	Construction of Jawan Barrack with BCL & Kote & Magazine, Kitchen, Dining hall & administration block at border out post Shbra under Sector HQ BSF Rai Ganj	CPWD	25	4	6	121.59										0	0			0	0	
33	BSF	Assam	Construction of gymnasium at ftr hq guwahati at BSF campus Patagno, Guwahati (Assam)	CPWD	4	5	0	315.84										0	0			0	0	
34	BSF	Tripura	Construction of GOs mess with 07 sutis for BSF HQ BSF campus Sephenjuri (Dharmahagar) under Ftr. HQ Tipura	CPWD	#VA	23	0	215										0	0			0	0	
35	BSF	Tripura	Construction of GOs mess with six suits at Sector HQ BSF Campus Gokulnagar under Tripura Ftr.	CPWD	#E	19	0	369.55										0	0			0	0	
36	BSF	Meghalaya	Construction of residential accommodation for Ftr. HQ BSF at Umpling, Shillong (Meghalaya) (SH: Construction of 04 nos. Type-II (two storied) and 08 nos. Type-III (Four storied) quarters.	CPWD	0	3	0	197.6										0	0			0	0	
37	BSF	Meghalaya	Construction of residential accommodation for Bn. HQ, BSF at Umpling, Shillong (SH:Construction 24 nos. Type-II (Four Storied) quarters in Phase-I	CPWD	0	3	0	346.79										0	0			0	0	
38	BSF	West Bengal	Construction of administration block with sand model for Bn. HQ at BSF campus Mathtpur, under South Bengal Ftr.	CPWD	1	18	0	254.34										0	0			0	0	
39	BSF	Meghalaya	Construction of residential quarters Type-II 24 nos., Sector HQ BSF Tura, Dobsipar	CPWD	0	4	0	374.87										0	0			0	0	
40	BSF	Manipur	Construction of 05 nos. residential quarters (SH: Type-IV/04 & Type-V/01 at Bn. HQ BSF campus Koirengai (Manipur)	CPWD	6	24	0	177.64										0	0			0	0	
41	CRPF	West Bengal	Construction of administration block for 3rd Signal, Salt Lake, Kolkata	CPWD	13	19	10	487.82	2	1.01				2	146 to 238	2.6								0
42	ITBP	Sikkim	Construction of garage store and sanitary box for Sector HQ (North East-2) I.T.B.P at Tadong Gangtok	CPWD	0	1	20	78.89	32	5.09				80	(-) 100 to 7835	42.5								0
43	ITBP	Sikkim	Water supply scheme in Lingdum 13th Bn. Lingdum	CPWD	5	1	26	178.1	10	2.65														0
44	ITBP	Arunachal Pradesh	Construction of Training shed at Lohitpur	CPWD	3	1	8	115.35	35	5.08				28	(-)100 to 1666	26.3								0
45	ITBP	Arunachal Pradesh	Construction of MT Garage & work shop at Sector HQ (Itanagar)	CPWD	!	Nil	40	298.51	20	43.67				47	(-) 100 to 531	27								0
46	ITBP	Arunachal Pradesh	Construction of GOs mess & singal officer accommodation at 25th Bn., Tezu	CPWD	10	7	4	267.46		0														0
47	ITBP	Arunachal Pradesh	Construction of Water Based Macadam (WBM) road & recarpeting of road at 9 <sup>th</sup> Bn., Lohitpur	CPWD	27	3	0	193.16	3	5.57				6	38 to 143	6.08								0
48	ITBP	Sikkim	Construction of SO's mess & suites at Lingdum	CPWD	4	2	8	260.21	4	2.55				3	50to 66	17.4								0
49	ITBP	Arunachal Pradesh	Construction of boundary wall with elevated watch tower, guard room and sentry post with gate at Mohanbari.	CPWD	9	6	2	175.23	54	10.68	4	0.31		26	(-)10 to 466	39.4								0

50	ITBP	Arunachal Pradesh	Construction of GOs mess and suits for ITBP at Itanagar (AP)	CPWD	20	3	6	215.26	13	5.85	7	1.28	53	(-) 100 to 1766	33.4	0
51	ITBP	Assam	Installation of filtration plant covering of open area and additional horticulture work at transit camp for ITBP Jhalukbari, Guwahati.	CPWD	1	9	4	76.52		0		0			0	0
52	NSG	West Bengal	Construction of boundary wall at RC Kolkatta	CPWD	E	3	7	471.78	2	10.59		0	1	30	1.06	0
53	SSB	Assam	Construction of Type-III/8 (three storied) at 33rd Bn. Rangia	CPWD	2	2	2	179.08	3	2.33		0	9	204	9.38	0
54	SSB	Assam	Construction of Type-III/18 (three storied) at 33rd Bn. Rangia (P-II)	CPWD	2	2	1	322.34		0	0	0	7	285	130	0
55	SSB	Arunachal Pradesh	Construction of Type-IV/02 & T-V/1 at 34th Bn. Dirang	CPWD	5	4	14	140.84	5	1.6		0	124	(-) to 463	30.2	0
56	SSB	Arunachal Pradesh	Construction of Type -III/8 nos. quarters. at 34th Bn. Dirang	CPWD	25	3	6	155.79	2	0.29	1	0.24	51	(-)100 to 218	8.27	0
57	SSB	Arunachal Pradesh	Construction of Type-V/02 nos. residential quarters. at 38th Bn. Tawang	CPWD	7	2	0	140.62	15	35.47		0	48	(-)100 to 187	6.82	0
58	SSB	Arunachal Pradesh	Construction of Type-IV/06 nos. quarters at 38th Bn. Tawang	CPWD	7	2	0	218.01		0		0			0	0
59	SSB	Assam	Construction of boundary wall with 7 f watch tower at Bn. HQrs Sarbahure (Bhairabarrackunda)	CPWD	5	5	3	348.61	4	3.68	2	1.08	51	626	93.6	0
60	SSB	Assam	Construction of SOs mess for 23rd Bn. at village Sarbeherua (Udalguri)	CPWD	1	8	2	133.86	31	7.06		0	108	4780	41.4	0
61	SSB	Assam	Construction of quarter guard building for 23rd Bn. at village Sarbeherua (Udalguri)	CPWD	1	8	2	246.05	3	0.78		0			0	0
62	SSB	Assam	Construction of Tradesingle menen Shop at village Sarbeherua (Udalguri)	CPWD	2	8	2	74.34	4	0.63		0	54	1445	12	0
63	SSB	Assam	Construction of river training work, retaining wall and boundary wall on northern side of SSB Campus Bongaigaon	CPWD	16	16	23	118.13	5	1.69	3	2.56			0	0
64	SSB	Uttra Khand	Construction of permanent infrastructure at border out post Co. HQ Sunder Nagar	CPWD	4	6	11	339.00	1	0.01		0	1	100	0.15	0
65	SSB	Assam	Construction of quarter Guard including development of site Bn. HQrs SSB Kokrajhar	CPWD	14	7	0	187.14		0		0			0	0
66	SSB	Assam	Construction of 10 bedded hospital including development of site for Bn. HQrs at Kajalgaon	CPWD	15	6	0	373.43		0		0			0	0
67	SSB	Assam	Construction of GOs mess with six nos. suits for Bn. HQrs SSB Kajalgaon	CPWD	15	6	0	187.29		0		0			0	0
68	SSB	Assam	Construction of new 250 KVA Sub station building at CTC SSB Salonibari.	CPWD	3	8	8	71.18		0		0			0	0

69	AR	Manipur	Construction of 01 block of 03 nos. single menbarrack for 06 NCOs and 60 ORs (G+II) and 01 No administration Block (G+I)for 21 Assam Rifles at Kakching	NPCCL	30	5	1	412.91						0	0	0	0		
70	AR	Meghalaya	Construction of 01 block of 03 nos. single men(G+II), black top bituminous road and main drain for Assam Rifles at Laitkor, Shillong (Meghalaya)	NPCCL	3	0	1	297.48						0	0	5	- 100to 491	17.62	0
71	AR	Tripura	Construction of 16 nos. Type-II (G+III) SF quarters for Assam Rifles at Agartala (Tripura)	NPCCL	4	0	0	236.91	7	1.53				0	2	(-)100	0.9	0	
72	AR	Manipur	Construction of Magazine building for AR Bn.at Kakching	NPCCL	5	0	2	203.99						0	5	100to 537	30.9	0	
73	AR	Nagaland	Construction of 12 nos. T-II (G+II) quarters in 02 Blocks for AR at Tuensang (Nagaland)	NPCCL	8	0	1	347						0	2	-32to - 100	3.08	0	
74	AR	Manipur	Construction of Bdywall with RCC Posts and 1.35 KM New road for Assam Rifles Bn. at Khuga (Manipur)	Himachal PradeshL	3	0	5	492.23						0			0	0	
75	AR	Manipur	Construction of 01 block of 03 nos. single menbarrack (G+II) and 01 block of cook house cum dining hall for AR Bn. at Phundrei	NPCCL	0	0	3	446.02						0	3	-85to - 100	13.53	0	
76	AR	Assam	Construction of 01 block of 04 nos. single menbarrack (G+III) and Bituminous road for Assam Rifles Bn. at Srikona Silchar	NPCCL	#	Nil	2	474.72	4	21.55				0	3	- 59 to 90	74.69	0	
77	AR	Manipur	Construction of 01 block of 04 nos. single men barrack (G+III) and 01 No cook house cum dining hall for Assam Rifles for Assam Rifles Bn. at Khuga(Manipur)	Himachal PradeshL	2	0	6	465.81	1	27.97				0	3	(-)49 to -100	17.1	0	
78	AR	Manipur	Construction of residential building boundary wall around Mantripukhri Garrison at Mantripukhri (Manipur)	NPCCL	0	1	3	498						0	1	-51	210	0	
79	AR	Manipur	Construction of 03 nos. single menbarracks (G+II) with approach road for Assam Rifles at Kangvai (Manipur)	NPCCL	0	1	2	488.98						0			0	0	
80	AR	Manipur	Construction of residential buiuldings support facility like CH/DH and internal road for KLP location of Assam Rifles at Modi (Manipur)	NPCCL	2	0	1	485.21						0			0	0	
81	AR	Assam	Construction of 01 block of 03 nos. single men barrack (G+II) and 01 block of 06 nos. Type -II (G+II) for No 2 Transit Camp at Jorhat (Assam)	NPCCL	1	2	3	474.4	1	6.18				0	11	(-)100 to 130	77.1	0	
82	AR	Manipur	Construction of 04 block of 24 nos. Type-II(G+II) for AR Bn. at Kangvai (Manipur)	NPCCL	1	2	2	481.16						0			0	0	
83	AR	Tripura	Construction of 02 nos. Type-V quarters, 04 nos. single junior commissioned officers accommodation and 16 nos. Type-II quarters for Assam Rifles Bn. at Udaipur (Tripura)	NPCCL	0	0	3	447.32	26	3.73				0	18	(-)100 to 1047	23.5	0	
84	AR	Assam	Construction of 32 nos. Type-II quarters (SF) for Assam Rifles Bn. at Jorhat (Assam)	NPCCL	0	1	2	425.67	3	4.89				0	10	(-)100 to 70	93.4	0	

85	AR	Tripura	Construction of 06 nos. fbarracks with development woks for Assam Rifles Bn. at Radhanagar (Tripura)	NPCCL	0	0	3	364.52		0	0			0	0	
86	AR	Assam	Construction of 02 nos. Type-V (G+1) with allied services and development works for Assam Rifles at Haflong (Assam)	NPCCL	1	0	10	195.03		0	0			0	0	
87	AR	Manipur	Construction of 12 nos. Type-II (G+II) in 2 block and 10 nos. Type-IV(G+1) in 5 blocks with allied services and development works for Assam Rifles at Mantripukhri (Manipur)	NPCCL	0	0	0	493.67		0	0			0	0	
88	AR	Nagaland	Construction of 06 nos. Type-III quarters (G+II) in 01 block, 02 nos. Type-IV (G+I) in 01 block and 02 nos. Type-V quarters for AR Bn. at Wokha (Nagaland)	NPCCL	0	0	2	496		0	0			0	0	
89	AR	Manipur	Construction of 03 nos. single men barrack (G+II) with approach road for KLP location of Assam Rifles Bn. at Khuga(Manipur)	Himachal PradeshL	0	0	2	252.42		0	0			0	0	
90	AR	Manipur	Construction of one block of 03 nos. singlemen barracks (G+II) with approach raod for new localation of Assam Rifles at Phunderi (Manipur)	NPCCL	0	0	4	427.25		0	0	0	4	-100 to 246	98.92	0
91	AR	Arunachal Pradesh	Augmentation of water Supply Scheme & 1 lac capacity PS overhead tank with staging & allied services for residential complex at Jairampur (AP)	Uttar PradeshJN	2	4	11	409.43		0	0			0	0	
92	AR	Manipur	Construction of security wall including main gate, sentry posts, security lights etc for residential accommodation for AR Bn. at Modi (Manipur)	NPCCL	2	2	5	450.06		0	0			0	0	
93	AR	Manipur	Construction of administration block (G+1) including allied services and development works for Assam Rifles new KLP at Phundrei (Manipur)	NPCCL	0	3	3	461.51		0	0			0	0	
94	AR	Manipur	Constructionof quarter Guard, Kote, Armoury and Armr shop including development works and internal road for Assam Rifles Bn. at Modi (Manipur)	NPCCL	3	0	2	245.42		0	0			0	0	
95	AR	Nagaland	Construction of 08 nos. Type -II (G+III) in one bleok with allies services and development works for AR works at Zunheboto (Nagaland)	NPCCL	2	3	3	215		0	0			0	0	
96	AR	Manipur	Construction of 20 Bedded Hospital including development works for AR Bn. at Khuga (Manipur)	Himachal PradeshL	2	1	3	359.59		0	0	0	2	-100to 47	34.91	0
97	AR	Manipur	Construction of 24 nos. Type-II SF quarters G+II including development works and allied services for IGAR (S) at Manthripukhari, Manipur	NPCCL	4	0	2	482.83	2	30.32	0	2	(-)100	7.68	0	
98	AR	Meghalaya	Construction of Central Sewage System of residential accommodation of DGSE of HQ DGAR at Laitkor, Shillong (Meghalaya)	Uttar PradeshJN	1	3	3	492.69		0	0			0	0	



99	AR	Assam	Construction of security wall in 1.7 km length with 02 nos. main entry gate and other related development work at new AR KLP at Guwahati	Uttar PradeshJN	1	1	20	435.44		0	0			0	0
100	AR	Manipur	Construction of security wall including main gate security light foot path with plan sump IRP & 100 KVA transformer with HT/LT It & sub stn for residential. complex of AR Bn. at Keithalmanbi (Manipur)	NPCCL	1	3	6	475.52		0	0			0	0
101	AR	Nagaland	Construction of 02 nos. Type-IV (G+I) quarters with allied services and development work for AR Bn. at Wokha Nagaland	NPCCL	3	0	3	130		0	0			0	0
102	AR	mizoram	Supply and installation of 01 x 250 KVA transformer for residential complex, street lines, security lights and allied services for AR Bn. at Lunglei (Mizoram)	Himachal PradeshL	3	1	3	89.43		0	0			0	0
103	AR	Assam	Construction of 01 No Type-VI (G+I) in one block with allied services and development works for HQ IGAR (East) at Srikona (Assam)	NPCCL	0	0	3	80.32		0	0			0	0
104	AR	Manipur	Construction of 04 nos. single officerss accommodation (G+I) in 1 block with allied services and development works for AR Bn. at Mantripukhri (Manipur)	NPCCL	7	0	2	85.29		0	0			0	0
105	AR	Assam	Construction of 02 nos. Type-V quarters (G) in 1 block with allied services and development works for HQ 25 Sector AR at Jorhat (Assam)	NPCCL	14	0	2	98.38		0	0			0	0
106	AR	Nagaland	Construction of 08 nos. single junior commissioned officers accommodation (G+III) in one block with allied services and development works for AR Bn. at Chieswama	NPCCL	1	0	6	106.35		0	0			0	0
107	AR	Nagaland	Construction of 08 nos. single junior commissioned officers (G+III) in one block including development works and allied services for Sector HQ AR at Tuensang (Nagaland)	NPCCL	13	0	2	112.3		0	0			0	0
108	AR	Manipur	Construction of 01 No single menbarrack (G) in 01 block with allied services and development works for HQ 10 Sector AR at Somsai (Manipur)	NPCCL	0	0	3	119.34		0	0			0	0
109	AR	Manipur	Construction of 02 nos. Type-V quarters (G) in 1 block including development works and allied services for 4 Workshop AR at Keithalmanbi (Manipur)	NPCCL	7	0	2	128.22		0	0			0	0
110	AR	Nagaland	Construction of 06 nos. Type-III (G+II) in one block including development works and allied services for AR Bn. at Kohima (Nagaland)	NPCCL	0	0	2	137.35		0	0			0	0
111	AR	Nagaland	Construction of 16 nos. single junior commissioned officers accommodation (G+III) in 02 blocks I with allied services land development works for AR Bn. at Naginimora (Nagaland)	NPCCL	0	0	3	178.71		0	0			0	0

112	AR	Assam	Construction of 11 nos. single junior commissioned officers (G+II) of 06 units in 01 block and 05 units in 01 block (G+II) for No 3 Workshop AR and 01 No single menbarrack (G) in 01 block for ARDB & TC with allied services and development works at Jorhat (Assam)	NPCCL	5	2	3	185.83							0	0			0	0	
113	AR	Nagaland	Construction of 14 nos. single junior commissioned officers (G+III) in one block with allied services and development works for AR Bn. at Zunheboto (Nagaland)	NPCCL	12	0	1	188.79							0	0			0	0	
114	AR	Manipur	Construction of Housing project- 02 nos. Type-IV quarters (G+I) in 01 block and 02 nos. Type-V quarters (G+I) in 1 block with allied services and development works for AR Bn. at Phundrei (Manipur)	NPCCL	0	0	2	239.27							0	0			0	0	
115	AR	Assam	Construction of 08 nos. single officer (G+III) in one Block and 07 nos. single civilian accommodation (G+III) in one Block including development works and allied services for AR Bn. at Srikona (Assam)	NPCCL	6	8	6	261							0	0			0	0	
116	AR	Assam	Construction of 06 nos. Type-V quarters (G+II) in one block with allied services and development works for IGAR (East) at Srikona (Assam)	NPCCL	0	0	3	325.51							0	0			0	0	
117	AR	Manipur	Construction of 24 nos. single junior commissioned officers accommodation (G+III) in 3 block with allied services and development works for AR Bn. at Kangvai (Manipur)	NPCCL	2	1	2	340.2							0	0			0	0	
118	AR	Nagaland	Construction of 24 nos. Type-II quarters (G+III) in 03 block with allied services and development works for AR Bn. at Naginimora (Nagaland)	NPCCL	1	2	2	362.7							0	0			0	0	
119	AR	Meghalaya	Construction of 04 nos. single menbarrack (G+II) in 1 block with allied services and development works for ARC & MC, Laitkor (Shillong)	NPCCL	1	0	2	364.53							0	0	0	7	- 100to 785	64.65	0
120	AR	Nagaland	Construction of 04 nos. single men barrack (G+III) in one block including development works and allied services for AR Bn. at Tuensang (Nagaland)	NPCCL	2	1	2	430.33							0	0			0	0	
121	AR	Manipur	Construction of housing project-24 nos. Type-II quarters (G+III) in 03 blocks with allied services and development works for AR Bn. at Pallel (Manipur)	NPCCL	0	0	14	457.25							0	0			0	0	
122	AR	Manipur	Construction of housing project-24 nos. Type-II quarters (G+III) in 3 blocks with allied services and development works for AR Bn. at Modi (Manipur)	NPCCL	0	1	2	452.99							0	0			0	0	
123	AR	Manipur	Construction of housing project-24 nos. Type-II quarters (G+III) in 3 blocks with allied services and development works for AR Bn. at Modi (Manipur)	NPCCL	0	1	2	452.99							0	0			0	0	

124	AR	Manipur	Construction of 12 nos. single junior commissioned officers accommodations (G+II) in 2 blocks and 16 nos. Type-II quarters (G+III) in 2 blocks with allied services and development works for AR Bn. at Mantripukhri (Manipur)	NPCCL	7	1	3	457.48							0	0		0	0
125	AR	Manipur	Construction of housing project- 24 nos. Type-II quarters (G+III) in 03 blocks with allied services and development works for AR Bn. at Phundrei (Manipur)	NPCCL	0	0	2	462.04							0	0		0	0
126	AR	Manipur	Construction of housing project- 24 nos. Type-II quarters (G+III) in 03 blocks with allied services and development works for AR Bn. at Phundrei (Manipur)	NPCCL	0	0	2	462.04					1	128	0	0		3.99	0
127	AR	mizoram	Construction of 08 nos. single junior commissioned officers accommodation (G+III) in 1 block along with development works and allied services for AR Bn. at Lunglei (Mizoram)	EPIL	0	3	2	113.17							0	0		0	0
128	AR	Manipur	Construction of housing project-02 dwelling units Type-V quarters in (G) configuration in 01 block at Khuga (Manipur)	Himachal PradeshL	1	0	14	155.3							0	0		0	0
129	AR	Manipur	Construction of 1.25 KM internal road for proposed housing project of 128 dwelling units at Khuga (Manipur)	Himachal PradeshL	1	0	2	202.16							0	0		0	0
130	AR	Manipur	Construction of 1.5 Km internal road for proposed housing project of 150 dwelling units at Kangvai (Manipur)	Himachal PradeshL	0	0	2	242.59							0	0		0	0
131	AR	Manipur	Construction of housing project-16 dwelling units Type-II quarters in (G+III) configuration at Khuga (Manipur)	Himachal PradeshL		4	4	310.29							0	0		0	0
132	AR	Manipur	Construction of housing project-05 dwelling units tupe-V quarters in (G+I) configuration in 02 blocks at Kangvai (Manipur)	Himachal PradeshL	0	0	2	340.1							0	0		0	0
133	AR	Manipur	Construction of 04 nos. single men barrack (G+III) including allied services and development works for AR Bn. at Khuga (Manipur)	Himachal PradeshL		0	3	441.65							0	0		0	0
134	AR	Manipur	Construction of 1 No storage accommodation (G) in 1 block including development works and allied services for 4 workshop AR at Keithalmanbi (Manipur)	NPCCL	7	1	0	67.53							0	0		0	0
135	AR	Assam	Construction of storage accommodation (G) in 1 block including development works and allied services for 3 workshop AR at Jorhat (Assam)	NPCCL	7	0	2	72.95							0	0		0	0
136	AR	Manipur	Construction of 1 No administration block (G) in 1 block including development works and allied services for 4 workshop AR at Keithalmanbi (Manipur)	NPCCL	7	0	7	78.37							0	0		0	0
137	AR	Assam	Construction of Regimental School (G+I) in 01 block with allied services and development works for AR Bn. at Lokhra (Assam)	NPCCL	0	0	3	94.52							0	0		0	0
138	AR	Assam	Construction of Regtl School (GH+I) in 1 block with allied services and development works for AR Bn. at Haflong (Assam)	NPCCL	0	0	3	95							0	0		0	0

139	AR	Manipur	Construction of Recreation Room (G) in 1 block with allied services and development works for AR Bn. at Moreh (Manipur)	NPCCL	3	1	4	96.57	0	0	0	0
140	AR	Nagaland	Construction of 01 No Junior Commissioned Officer's Club (G) in one blocks including development works and allied services for AR Bn. at Ghaspani (Nagaland)	NPCCL	0	1	3	121.25	0	0	0	0
141	AR	Assam	Construction of quarter Guard, Kote, Armourer shop (G) in one block with allied services and development works for AR Bn. at Haflong (Assam)	NPCCL	0	1	2	221.4	0	0	0	0
142	AR	Manipur	Construction of quarter Guard, Kote, Armourer shop (G) in 1 block with allied services and development works for AR Bn. Kangvai (Manipur)	NPCCL	2	1	2	232.03	0	0	0	0
143	AR	Nagaland	Construction of 01 No storage accommodation (G) in one block with allied services and development works for AR Bn. at Ghaspani (Nagaland)	NPCCL	2	1	2	257.8	0	0	0	0
144	AR	Manipur	Construction of 01 No. office building (G+I) in one block with allied services and development works for HQ IGAR (S) AR at Mantripukhri (Manipur)	NPCCL	2	2	3	260.04	0	0	0	0
145	AR	Manipur	Construction of magazine building with allied services and development works for AR Bn. at Jwalamukhi (Manipur)	NPCCL	12	0	2	260.07	0	0	0	0
146	AR	Manipur	Construction of magazine building with allied services and development works for AR Bn. at Phunderi (Manipur)	NPCCL	9	4	2	264.21	0	0	0	0
147	AR	Manipur	Construction of 01 No. officer club (G+I) in 1 block with allied services and development works for AR Bn. at Modi (Manipur)	NPCCL	0	0	3	326.4	0	0	0	0
148	AR	Assam	Construction of MT accommodation in 03 blocks including allied services and development works for AR Bn. at Haflong (Assam)	NPCCL	0	0	3	214.53	0	0	0	0
149	AR	Manipur	Construction of 02 nos. Cook House cum Dining Hall (G) in 2 blocks with allied services and development works and Construction of Recreation Room (G) in 1 block with allied services and development works for AR Bn. at Kangvai (Manipur)	NPCCL	1	3	3	302.22	0	0	0	0
150	AR	Manipur	Construction of 01 No storage accommodation (G) in one block with allied services and development works for AR Bn. at Pallel (Manipur)	NPCCL	7	0	2	259.53	0	0	0	0
151	AR	Tripura	Construction of boundary wall for AR Bn. at Teliamura (Tripura)	NPCCL	0	0	3	428.9	0	0	0	0
152	AR	Arunachal Pradesh	Construction of 10 nos. single junior commissioned officers accommodation in 02 blocks of (G+I) including infrastructural development works for AR Bn. at Jairampur (Arunachal Pradesh)	EPIL	#VA!	1	3	123.43	0	0	0	0

153	AR	mizoram	Construction of Family Welfare Centre alongwith allied services and development works for AR Bn. at Serchip (Mizoram)	EPIL	0	0	7	125.96							0	0
154	AR	Arunachal Pradesh	Construction of Motor Transport (MT) accommodation with Technical stores (G+I) for AR Bn. at Khonsa (Arunachal Pradesh)	EPIL	#V	0	13	195.76							0	0
155	AR	mizoram	Construction of storage accommodation (G+I) including infrastructural development works for AR Bn. at Serchip (Mizoram)	EPIL	0	0	5	238.48							0	0
156	AR	mizoram	Construction of quarter Guard/Kote/Armoury including infrastructural development works for AR Bn. at Lunglei (Mizoram)	EPIL	0	0	3	244.64							0	0
157	AR	Manipur	Construction of Family Welfare Centre along with allied Service and development works for Assam Rifles Bn. at Khuga, (Manipur)	Himachal PradeshL	2	1	4	118.93							0	0
158	AR	Manipur	Construction of officers club alongwith allied services and development works for AR Bn. at Khuga (Manipur)	Himachal PradeshL	2	0	3	301.73							0	0
159	AR	Manipur	Construction of 01 No. administration Block (G+I) including allied services and development works for AR Bn. at Khuga (Manipur)	Himachal PradeshL		0	3	414.27							0	0
160	AR	Nagaland	Construction of Swimming Pool along with allied services and development works for ARegional Training Centre & School at Sukhovi (Nagaland)	Himachal PradeshL	0	0	5	497.35							0	0
161	AR	Manipur	Construction of Central Sewarage System for AR Bn. at Kangvai (Manipur)	Uttar PradeshJN	4	0	10	169.54							0	0
162	AR	Manipur	Providing of water supply scheme for AR Bn. at Kangvai (Manipur)	Uttar PradeshJN	4	0	11	193.1							0	0
163	AR	Manipur	Providing of Water Supply scheme for AR Bn. at Khuga (Manipur)	Uttar PradeshJN	4	0	10	193.46							0	0
164	AR	Manipur	Providing of erection and stringing of one separate 11 KVA dedicated line from 33/11KV Walnging substation and supply, Erection, Testing and commissioning of 1 set of 11 KV, VCB Incoming/Outgoing panel at 33/11 KV walnging sub station for Phundrei (Manipur)	ECB	7	4	0	71.97							0	0
165	AR	Manipur	Construction of 24 nos. Type-II quarters (G+III) in 03 block with allied services and development works for AR Bn. at Moreh (Manipur)	NPCCL	9	1	4	493.66							0	0
166	AR	Manipur	08 nos. single officers accommodation (G+I) in 02 blocks with allied services and developmetnt works for AR Bn. at Moreh (Manipur)	NPCCL	8	1	4	179.77							0	0

167	BSF	West Bengal	Construction of boundary wall (Length- 7300 metre) along the periphery of Signal Training Centre, BSF in West Bengal	CPWD	5	24	18	521.15	4	11.01		0	4	90 to 664	51.8	0
168	BSF	Assam	Construction of administration Block for Ftr. HQ, BSF Campus	CPWD	12	2	6	1,503.61	1	0.94		0			0	0
169	BSF	West Bengal	Construction of 48 nos. Type-II residential quarters for Bn. HQ at Radhabri under Sector HQ BSF Siliguri.	CPWD	4	1	0	615.36		0		0			0	0
170	BSF	Meghalaya	Construction of 64 nos. Type-II quarters for Battalion HQ BSF campus at Tura (New Location), Bewegre.	CPWD	0	4	0	1,038.54		0		0			0	0
171	BSF	Tripura	Sanction for construction of administration block for Sector HQ BSF Gokulnagar, under Tripura Frontier.	CPWD	#VA	48	0	615.3		0		0			0	0
172	BSF	Tripura	Sanction for construction of one number 120 men barrack at Battalion HQ BSF campus Siphznjuri Dharmanagar under Tripura Frontier	CPWD	#VA!	16	0	636.45		0		0			0	0
173	BSF	Tripura	Constructions of 120 nos. men barrack for Bn. HQ BSF campus Kumarghat (Tripura).	CPWD	#VA	4	0	527.92		0		0			0	0
174	CISF	Assam	Construction of non-residential accommodation for CISF Group HQ Guwahati	CPWD	21	18	8	1,095.17	34	111.8		0	119	38 to 2650	270	0
175	CRPF	Assam	Construction of 3 nos. 180 men barrack (Revised sanction instead of ₹ 863.45 lakh dated 27/11/2009) at Group Centre (Group Centre) Khatkhati	CPWD	1	11	12	2,298.31	11	7.19		0	140	682 to 789	640	0
176	CRPF	Assam	Construction of boundary wall, main gate, guard room, sentry post & watch tower at Group Centre Silchar	CPWD	16	5	3	299	13	11.87	1	3.45	9	(-) 45 to 10469	299	0
177	CRPF	Tripura	Construction of boundary wall with two main gates, watch towers 6 nos., sentry posts 18 nos. & guard room at Group Centre Agartala	CPWD	1	7	2	325.37	1	2.66		0	83	(-)100 to 761	141	0
										0		0			0	0
178	CRPF	West Bengal	development & bulk services at Group Centre Siliguri	CPWD	5	7	44	2,865.59	121	248.3	3	35.5 7	41	88 to 10297	250	0
179	CRPF	West Bengal	Construction of 3 nos. 240 Men barrack at 207 COBRA Bn. Salboni, West Bengal	CPWD	7	2	5	2,548.83	16	18.12	21	119. 2	37	32 to 8425	76.2	0
180	CRPF	West Bengal	Construction of 222 nos. family quarters. (T/II-180, T/II-27, T/IV-14 & T/V-1). at 207 COBRA Bn. Salboni, West Bengal	CPWD	10	6	2	3,246.83	30	18.53	11	23.6 2	20	31 to 1235	68.2	0
181	CRPF	Assam	Construction of GOs mess at Group Centre Silchar, Assam	CPWD	26	20	7	582.29		0		0			0	0
182	CRPF	West Bengal	Construction of 20 bedded hospital/ at 207 COBRA Bn. Salboni, West Bengal	CPWD	19	2	7	540.56	44	24.65		0	23	34 to 706	22.9	0
183	CRPF	West Bengal	Construction of GOs mess/suites at Group Centre Siliguri, West Bengal	CPWD	44	3	8	729.69	6	0.62		0	4	182 to 714	10.3	0
184	CRPF	West Bengal	Construction of 47 nos. Type-II family quarters at 207 COBRA Bn. Salboni, West Bengal	CPWD	1	2	7	578.32		0	1	0.21	4	35 to 145	86.3	0

185	CRPF	Assam	Construction of 3 nos. 240 Men barracks at 210 CoBRA Bn., Dalgaon, Darrang, Assam	CPWD	2	6	6	2,437.29		0	0			0	0	
186	CRPF	Assam	Construction of SOs mess/ dormitory for 210 CoBRA Bn., Dalgaon, Assam	CPWD	2	6	5	659.78		0	0			0	0	
187	CRPF	West Bengal	Construction of 224 Type-II quarters at Group Centre, CRPF, Siliguri (construction of 112 quarters-Split-I)	CPWD	2	7	6	2,292.69	77	173.7	8	96.7 1	64	31 to 1470	379	0
188	SSB	Assam	Construction of permanent infrastructure at Bn. HQ SSB Gossai Gaon, Assam	CPWD	3	15	4	1,348.38		0	0			0	0	
189	SSB	Assam	Construction of administration Block at Sector HQ Rangia, Assam	CPWD	15	#	0	1,100.00		0	0			0	0	
190	SSB	Assam	Construction of residential quarters at Sector HQ Rangia, Assam	CPWD	18	12	0	566.64		0	0			0	0	
191	SSB	Arunachal Pradesh	Construction of infrastructure (45 nos. Type-II quarters) at 38th Bn. SSB Tawang under SSB Ftr. Guwahati.	CPWD	3	9	0	770		0	0			0	1.13	
192	SSB	Assam	Construction of administration block at Sector HQ Rangia, Assam	CPWD	19	12	0	533.53		0	0			0	0	
193	SSB	Assam	Construction of infrastructure at 47th Bn. SSB Bijni, Assam	NBCC	E	3	0	3,366.20		0	0			0	0	
194	AR	Nagaland	Construction of 12 nos. Type-III in (G+II) and 12 nos. Type-II quarters (G+II) for 5 Sector HQ and 78 nos. Type-II quarters (G+II) for Assam Rifles Bn. at Chieswema (Nagaland)	NPCCCL	4	6	10	1,028.02		0	0			0	0	
195	AR	Manipur	Construction of 06 nos. single junior commissioned officers living accommodation (G+I), 01 Block of 03 nos. single men barrack (G+II), 01 No administration block (G+I) and 01 No officers mess for Sector HQ and 01 Block of 03 nos. single men barrack (G+I) for Assam Rifles Bn. at Keithalmanbi (Manipur)	NPCCCL	1	3	6	1,336.39		0	0			0	0	
196	AR	Manipur	Construction of one Block of 04 nos. single men barrack (G+III) for Assam Rifles Bn. at Jawalamukhi and one block of 04 nos. single men barrack (G+III) for Assam Rifles Bn. at Maram (Manipur)	NPCCCL	2	4	1	645.77		0	0			0	0	
197	AR	Mizoram	Construction of accommodation for Assam Rifles at Zokhawsang, Mizoram	EPIL	#VE	22	27	8,660.00	1	2.5	0	18	(-100 to 829)	682	0	
198	AR	Nagaland	Construction of 09 blocks of 72 nos. T-II quarter (G+III) for AR Bn. at Kashirambasti (Nagaland)	NPCCCL	2	4	1	1,126.50		0	0			0	0	
199	AR	Assam	Construction of 01 block of 04 nos. single men barrack, 01 No junior commissioned officers mess and 01 nos. 20 bedded hospital for Assam Rifles Battalion at Haflong (Assam)	NPCCCL	3	3	3	597.28	1	4.67	0			0	0	

200	AR	Nagaland	Construction of 08 blocks of 64 nos. Type-II quarters (G+III) for Assam Rifles Bn. at Mokokchung (Nagaland)	NPCCL	2	4	1	1,182.05	2	2.74	0	16	(-)100 to 100	18	2.05
201	AR	Assam	Construction of 12 nos. Type-III quarters (G+II) and 66 nos. Type-II quarters (G+II) SF accommodation at Jorhat (Assam)	NPCCL	16	6	0	861.24	5	6.6	0	13	(-) 100 to 70	30.3	3.98
202	AR	Arunachal Pradesh	Construction of 08 nos. single menbarrack (G+III), 04 nos. single officers accommodation, 12 nos. single junior commissioned officers accommodation, 01 No. administration Block (G+I), 01 No. officers mess, 01 No. junior commissioned officers mess for Assam Rifles Bn. at Khonsa (Arunachal Pradesh)	EPIL	6	5	2	1,685.83		0	0			0	3.97
203	AR	Assam	Construction of 64 nos. Type-II (G+III) quarters for Assam Rifles Bn. at Charduar (Assam)	EPIL	4	4	3	970.51		0	0			0	3.83
204	AR	Arunachal Pradesh	Construction of 48 nos. Type-II (G+III) quarters for Assam Rifles Bn. at Khonsa (Arunachal Pradesh)	EPIL	6	10	3	938.07		0	0			0	3.57
205	AR	Meghalaya	Construction of 72 nos. Type-II (G+III) SF accommodation for Assam Rifles at Laitkor, Shillong, Meghalaya	NPCCL	5	5	3	1,355.14	4	91.7	0	5	(-)100 to 3900	27	2.38
206	AR	Manipur	Construction of 01 nos. T-VI (GF) 04 nos. T-V (G+1), 13 nos. T-III, 18 nos. T-II (G+2) and 02 nos. S/officers accommodation for AR Sector HQ at Keithalmanbi, Manipur	NPCCL	0	11	1	1,008.46		0	0			0	1.71
207	AR	Nagaland	Construction of 07 km internal Rd for Assam Rifles Training Centre and School at Sukhovi, Nagaland	Himachal PradeshL	3	0	3	1,387.02	1	0.02	0	6	392 to 976	0.58	3.07
208	AR	Manipur	Construction of 72 nos. T-II accommodation with development works and ancillary service for AR Sector HQ/ Bn. HQ at Keithalmanbi at Manipur	NPCCL	0	3	4	1,480.42	2	39.45	0			0	5
209	AR	Manipur	Construction of 48 nos. Type-II(G+II) in 08 block and 07 nos. single junior commissioned officers accommodation with development works, water supply and external electrification for Assam Rifles at Jwalamukhi (Manipur)	NPCCL	1	2	2	1,207.16		0	0	1	48	14.8	9.33
210	CRPF	Maharashtra	Carrying out civil and electrical development work and bulk services for 206 Bn., CoBRA, Bhandara	CPWD	0	0	16	1402		0	0			0	0
211	SSB	Maharashtra	Construction of infrastructure at Reserve Battalion HQ SSB Yelki (Maharashtra)	NBCC	NA	NA	0	5369		0	0			0	0
212	BSF	Delhi	Providing 20 nos. 320 KVA DG set, at BSF HQ, CGO Complex, New Delhi	CPWD	4	3	9	86.1	2	0.51	0	10	(-)73 to 180	2.05	0
213	BSF	Delhi	Construction of 120 Men barrack at sts BSF Tigri, New Delhi	NBCC	0	3	8	484.29		0	0			0	0
214	BSF	Delhi	Construction of Type-III (14 nos.) and Type-IV (05) at Signal Training School Tigri	NBCC	0	4	7	415.73		0	0			0	0
215	CISF	Delhi	Construction of girls hostel at Shastri Park, New Delhi	DMRC	1	7	8	306	22	21.52	0			0	0



216	NSG	Delhi	Development of 05 acre land near IGI airport, raising of ground, New Delhi	CPWD	0	0	4	100	77	68		0			0	0
217	NSG	Delhi	Construction of semi permanent structure IGI airport, New Delhi	CPWD	7	1	3	704		0		0			0	0
218	NSG	Delhi	Upgradation of electric system for NSG campus in Manesar, Haryana	CPWD	1	1	9	99.75	10	1.42		0	7	(-)100 to 82	74	0
219	NSG	Delhi	Construction of boundary wall at NSG Head quarter Mehram Nagar, New Delhi	CPWD	5	7	5	226	16	8.66		0	6	(-)40 to 98	0.43	0
220	NSG	Delhi	Construction of special operation training centre building for NSG at Manesar, Haryana	CPWD	0	2	17	0.97		0		0			0	0
221	CISF	Delhi	Construction of 4 nos. men's barracks, GOs Mess for CISF at Special Security Group (SSG) Greater Noida	NBCC	0	1	1	2218	2	2.37		0	6	228 to 2140	18.5	0
222	CISF	Delhi	Construction of 108 nos. residential quarters for CISF at SSG Greater Noida	NBCC	0	5	4	1534.96	18	14.16		0	22	290 to 1678	188	0
223	CISF	Delhi	Construction of Non-residential building for CISF at Government Building Security (GBS) Mahipalpur, New Delhi	NBCC	4	34	6	9972	6	1.56		0			0	0
224	NSG	Delhi	Construction of 8 additional class rooms for montessori school, Manesar, Haryana	CPWD	2	0	6	97.73	12	2.1	6	0.02	62	30 to 3570	10.9	0
225	NSG	Delhi	Construction of Composite Structure for 52 Special action Group (SAG) Unit Samalkha	CPWD	3	29	89	4742	18	28	8	9	8	126 to 647	3.98	0
226	BSF	Madhya Pradesh	Construction of SO's mess and Hostel accommodation for 44 SOs at CSWT BSF, Indore	CPWD	6	6	43	497.46	24	8.14	1	0.47			0	0
227	BSF	Madhya Pradesh	Reconstruction & Strengthening of Front boundary wall Gates and Guard Rooms at CSWT BSF, Indore.	CPWD	6	11	43	96.19	28	11.23	2	13			0	0
228	BSF	Madhya Pradesh	Construction of Infrastructure For augmentation of training capacity at CSWT BSF, Indore	CPWD	0	0	0	Work not execute		0		0			0	0
229	BSF	Madhya Pradesh	Construction of administration and communication block for Reserve Bn. BSF Campus at Indore, Madhya Pradesh	NBCC	0	1	7	272.96		0		0			0	0
230	BSF	Madhya Pradesh	Construction of GOs mess with 07 suites for BSF Bn. HQ at Indore Campus Madhya Pradesh	NBCC	0	2	5	216.35		0		0			0	0
231	BSF	Madhya Pradesh	Construction of Type-III (G+2) residential, 26 nos. for BSF Bn. HQ at Indore Campus Madhya Pradesh	NBCC	1	2	5	475.81		0		0			0	0
232	BSF	Madhya Pradesh	Construction of Type-IV & Type-V residential-10 nos. for BSF Bn. HQ at Indore Campus Madhya Pradesh	NBCC	0	2	5	287.64		0		0			0	0
233	BSF	Madhya Pradesh	Construction of 34 Type-II (34 nos.) quarters for CSWT BSF at Indore	NBCC	3	4	6	461.01		0		0			0	0

234	BSF	Uttar Pradesh	Construction of Store Block, Tradesingle menan Shop & MT Complex for Bn. HQ BSF Campus Baad Mathura Uttar Pradesh	NBCC	0	4	4	492							0	0			0	0
235	BSF	Madhya Pradesh	Construction of Various Infrastructures at Newly upgraded Signal Training Centre (Signal Training Centre) BSF Indore, SH: Construction of MT Garage & Workshop	CPWD	NA	NA	0	A/A & ES Canceled							0	0			0	0
236	BSF	Madhya Pradesh	Construction of 120 Men Barrack For Sector HQ BSF, Bhopal	NBCC	2	4	7	470.19							0	0			0	0
237	CISF	Chhattisgarh	Construction of Training Block for 3rd Reserve Bn. Bhilai	CPWD	0	2	19	102	21	1.4	2	1.44	60	(-)100 to 245					10.6	0.5
238	CISF	Madhya Pradesh	Renovation of Darya Mahal of Regional Training Centre, Barwaha, Madhya Pradesh	CPWD	1	2	46	290	38	19.78	5	4.54							0	0
239	CISF	Madhya Pradesh	Construction of Inspection Gallery and Stage in existing minature firing range for Regional Training Centre, Madhya Pradesh	CPWD	10	1	5	60.37	7	6.14	1	0.81	28	40					26.4	0
240	CISF	Madhya Pradesh	Construction of 06 nos. quarters (Type-V 2 nos. and Type-IV 04 nos.) for Regional Training Centre, Madhya Pradesh	CPWD	5	16	44	168.57	17	6.25	1	2.25							0	0
241	ITBP	Madhya Pradesh	Construction of MT Complex and workshop at Telecom Bn., Shivpuri, Madhya Pradesh	CPWD	11	3	22	125.38	18	4.1		0	64	45					45.2	0
242	ITBP	Madhya Pradesh	Construction of Ammunition Shed Phase-I (6 nos.) at Karera, Madhya Pradesh	CPWD	11	4	25	487.63	23	15.53	7	12.24							0	0.59
243	ITBP	Madhya Pradesh	Construction of Ammunition Shed Phase-II (4 nos.) at Karera, Madhya Pradesh	CPWD	10	5	26	349.03	13	3.58	1	2.85							0	0
244	ITBP	Madhya Pradesh	Recarpetting of internal roads at Karera, Madhya Pradesh	CPWD	8	1	4	78.25	2	0.7		0							0	0
245	ITBP	Chhattisgarh	Construction of quarter Guard building for 38th Bn. ITBP at Raipur, Chhattisgarh	CPWD	4	4	10	271.88		0		0							0	0.05
246	ITBP	Chhattisgarh	Construction of SOs mess at 38 th Bn. Raipur, Chhattisgarh	CPWD	0	na	12	233.23		0		0							0	0
247	ITBP	Madhya Pradesh	development of electrical & civial works at Regional Training Centre, Karera, Madhya Pradesh	CPWD	18	11	18	489.58		0		0							0	0
248	BSF	Madhya Pradesh	Construction of various infrastructure at newly upgraded, Tekanpur, Madhya Pradesh	CPWD	0	0	0	not pertaning		0		0							0	0
249	BSF	Madhya Pradesh	Construction of one number 180 Men Barrack for BSF at CS MT Tekanpur Campus, Madhya Pradesh	NBCC	1	4	10	599.32		0		0							0	0
250	CRPF	Chhattisgarh	Construction of Combined administration n./quarter guard/Store block at Group Centre Bilaspur	CPWD	0	0	15	985.62	18	21.43	3	3.13	44	(-)94 to 819					11	0

251	CRPF	Chhattisgarh	Construction of 50 bedded composite hospital lat Group Centre Bilaspur	CPWD	7	6	15	1219.87	31	12.55	6	1.5	79	(-)100 to 1545	32	0
252	CRPF	Chhattisgarh	Construction of SOs mess/dormitory at Group Centre, Bilaspur, Chhattisgarh	CPWD	0	0	11	635.02	19	9.39		0	92	(-)100 to 1902	20.2	0
253	CRPF	Madhya Pradesh	Construction of 50 bedded hospital at Group Centre, CRPF Bangrasiya, Bhoapl	CPWD	1	5	8	1281.41	22	16.11	3	9.18	198	31	250	0
254	CRPF	Chhattisgarh	Construction of administration block buildings at 201 and 204 COBRA Bn., Jagdalpur, Chhattisgarh	NBCC	6	3	5	735.13	6	37.17		0	181	(-)100 to 8299	38.6	0
255	CRPF	Madhya Pradesh	Combined building of administration /Training Block/ Class Room / Sand Model Room-cum-lecture hall and 2 nos. 270 Men barracks at Counter Insurgency and Anti Terrorism (CIAT) training centre Shivpuri, Madhya Pradesh	NBCC	0	0	2	4202.75		0		0			0	0
256	CRPF	Madhya Pradesh	Construction of combined building of GOs mess & suites, SOs mess & badminton court and gymnasium at Central Training College (CTC) Shivpuri, Madhya Pradesh	NBCC	2	4	2	4170.84	12	95.03		0			0	0
257	CRPF	Chhattisgarh	Carrying out civil and electrical development works and bulk services for 201 & 204 CoBRA Bns. of CRPF at Jagdalpur	NBCC	2	4	6	1721.28		0		0			0	0
258	CRPF	Madhya Pradesh	Construction of 1 no. each 480 and 240 men barracks for 208 COBRA Bn., Balaghat, Madhya Pradesh	NBCC	6	2	3	2823.85	20	0.25		0			0	0
259	CRPF	Madhya Pradesh	Construction of GOs mess/suites, SOs mess/ dormitory, swimming cum driving poo, 1 & 3 nos. dog kennels for 208 Bn., CoBRA, Balaghat, Madhya Pradesh	NBCC	7	1	3	1387.6		0		0			0	0
260	CRPF	Madhya Pradesh	Carrying out development work and bulk services (Civil & Electrical works) for 208 Bn., Balaghat, Madhya Pradesh	NBCC	7	2	4	950.9		0	3	22.67			0	0
261	BSF	Gujarat	Construction of 10 Bedded Hospital with maternity ward for 11 Bn. BSF campuses Gandhidham including draingae and development works.	CPWD	9	3	4	98.85		0		0			0	0
262	BSF	Rajasthan	Construction of 1 No. 120 men barrack including development works at 84 Bn. BSFCampus-I located at Sum Road Jaisalmer, Rajasthan	CPWD	2	16	7	165.78	18	3.48	1	0.03	10	(-) 100 to 700	57.4	0
263	BSF	Rajasthan	Construction of quarter guard building at BSF campus, Udaipur, Rajasthan	CPWD	11	11	6	108.5	35	13.47	3	0.89	32	(-)100 to 705	26.8	0
264	BSF	Rajasthan	Construction of MT complex with garrage BSF campus bhramsar ramkunda for Bn. HQ under Sector HQ BSF, Rajasthan	CPWD	0	2	9	257	10	18.42	1	6.2	4	(-)100 to 1916	19.9	0
265	BSF	Rajasthan	Construction of provisioning complex for Sector HQ BSF campus Sum Road Jaisalmer, Rajasthan	CPWD	1	3	9	195	6	7.45	1	0.72	7	(-)100 to 1073	9.36	0
266	BSF	Gujarat	Construction of single menall arm workshop at Frontier HQ, BSF at Gandhinagar.	CPWD	3	3	54	162.84	21	6.35		0	19	31 to 306	7.91	0

267	BSF	Rajasthan	Construction of hanuman ki khejari firing range at BSF campus, 192 Bn. Rajasthan	CPWD	10	5	2	152.14	2	15.41		0	6	(-)100 to 56	61.3	0
268	BSF	Gujarat	Construction of Provisioning complex for Sector HQ BSF Gandhi Nagar, Gujarat	CPWD	6	19	3	371.64		0		0			0	0
269	CISF	Rajasthan	Construction of Semi permanent structures for CISF Regional Training Centre, Behror, Rajasthan	CPWD	1	0	3	299.5	4	4.33		0	44	(-)100 to 1200	61.4	0
270	CISF	Rajasthan	Construction of MT garage for Madhya Pradesh Regional Training Centre, Behror, Rajasthan	CPWD	6	5	7	79.6	1	0.33	4	13.1	53	(-)100 to 1078	22.5	0
271	CISF	Rajasthan	Construction of 05 nos. residential quarters (Type-V 1, Type-IV 4) for Regional Training Centre at Deoli, Rajasthan	CPWD	12	17	19	48.54	29	3.44		0	23	(-)100 to 3164	13.1	0
272	CISF	Rajasthan	Construction of sewage treatment plant for Regional Training Centre Behror, Rajasthan	CPWD	19	1	19	120.75	9	1.94		0	22	(-)100 to 700	8.32	0
273	ITBP	Rajasthan	Providing & Laying water supply line at 42 Bn., Jodhpur, Rajasthan	CPWD	4	1	4	64.72		0		0			0	0
274	BSF	Rajasthan	Construction of residential quarter (SH: 32 nos. Type-II, 16 nos. Type-III, 07 nos. Type-IV & 02 nos. Type-V) for Bn. HQ BSF campus at Alwar, Rajasthan	CPWD	5	15	5	736.3		0		0			0	0
275	CISF	Rajasthan	Construction of SO's mess for CISF Regional Training Centre, Behror, Rajasthan	CPWD	28	8	30	539.63		0		0			0	0
276	CISF	Gujarat	Construction of residential and non-residential buildings for CISF Group HQ Ahmedabad, Gujarat	NBCC	23	1	10	1576.6		0		0			0	0
277	CRPF	Rajasthan	Construction of boundary wall, main gate, guard room, watch towers and security lights at Group Centre-II Ajmer, Rajasthan	CPWD	4	3	0	919.1	10	11.3		0	50	(-)100 to 50	68.1	0
278	SSB	Rajasthan	Construction of residential building and non-residential building at Reserve Bn. HQ Maujpur, Alwar, Rajasthan	NBCC	9	10	0	3940.31		0		0			0	0
279	CISF	Karnataka	Construction of compound wall	CPWD	0	5	3	248		0		0			0	0
280	ITBP	Karnataka	Construction of boundary wall	CPWD	1	2	3	389	5	26.33		0	9	140 to 6013	63.4	0
281	BSF	Karnataka	Construction of providing internal roads, culverts etc for 82nd Battalion, Karahalli, Bengaluru Rural district, Karnataka	CPWD	9	22	20	492	10	34.02	3	8.31	2	122 to 123	1.85	0
282	BSF	Karnataka	Construction of 60 numbers of quarters	CPWD	8	8	10	827		0		0			0	0
283	CRPF	Karnataka	Construction of 208 family quarters.	CPWD	2	12	3	1229	8	15.62	4	92.4 2	13	106 to 770	49.8	12.3 4
284	BSF	Punjab	Construction of boundary wall, Madhopur	CPWD	2	5	2	100		0		0			0	0
285	BSF	Punjab	Construction of boundary wall at BSF campus 143 Bn. BSF K.M.S.Wala, Ferozepur, Punjab	CPWD	8	7	11	309		0		0			0	0

286	BSF	Punjab	Construction of sewerage treatment plant at BSF campus Bikki, Punjab	CPWD	15	18	15	214							0	0
287	BSF	Punjab	Construction of boundary wall with gates and sentry post at BSF campus 80 Bn., BSF, Khemkaran, Punjab	CPWD	15	4	4	161							0	0
288	BSF	Haryana	Construction of SOs mess building at BSF campus, Bhondsi, Haryana	CPWD	4	4	12	499							0	0
289	BSF	Jammu & Kashmir	Construction of 8 no double story quarters	NBCC	0	0	5	386							0	0
290	BSF	Haryana	Construction of 10 Bedded Hosiptal with maternity ward for Bn. HQ, Bhondsi	CPWD	0	0	0	Sactionc ansald							0	0
291	BSF	Punjab	Construction of barracks at Dera Baba Nanak, Punjab	CPWD	2	17	0	388							0	0
292	BSF	Himachal Pradesh	Construction of GOs mess, Kangra, Himachal Pradesh	CPWD	0	2	4	189							0	0
293	BSF	Haryana	Construction of main entrance gateway & dormitory block/side entrance gateway & dormitory block & refurbishment of boundry wall for Reserve Bn. BSF campus at Bhondsi, Gurgaon (Haryana)	NBCC	1	5	0	201							0	0
294	BSF	Jammu & Kashmir	Construction of 120 men barrack I/Nagar, Jammu & Kashmir	CPWD	5	13	0	462							0	0
295	BSF	Punjab	Construction of Sewage Treatment Plant of 0.2 million litres per day capacity for BSF Campus KMS Wala under Sector HQ BSF Ferozepur, Punjab	CPWD	8	19	0	83							0	0
296	BSF	Himachal Pradesh	Construction of Type III and IV quarters at Kangra, Himachal Pradesh	CPWD	1	4	0	433							0	0
297	ITBP	Jammu & Kashmir	Construction of MT workshop at Leh	CPWD	1	5	24	194		0	0	14	30 to 349	48		2.58
298	ITBP	Punjab	Construction of Type-1 to 1V quarters at Patiala	CPWD	0	3	6	182		0	0				0	1.28
299	ITBP	Haryana	Construction of Sewage Treatment Plant at Saboli, Haryana	CPWD	0	0	17	71.82		0	0				0	0
300	ITBP	Haryana	Construction of Store depot at Sabili, Jhajjar Haryana	CPWD	0	0	2	62		0	0				0	0
301	ITBP	Haryana	Construction of A.T. School and veterinary hospital at Bhanu, Panchkula	CPWD	7	20	10	88.47		0	0				0	0.75
302	ITBP	Jammu & Kashmir	Construction of GOs mess at 15 <sup>th</sup> Bn. Udhampur, Jammu & Kashmir	CPWD	0	0	14	425	26	3.73	0	45	30 to 2330	13		0
303	ITBP	Haryana	Construction of SOs mess at 28th Bn., Jatusana, Rewari, Haryana	CPWD	1	2	6	291		0	0				0	0
304	ITBP	Himachal Pradesh	Renovation of quarters for ITBP at Serhan, Himachal Pradesh	CPWD	1	3	2	118		0	0				0	0
305	ITBP	Haryana	Augmentation of Substation in residential campus at Ramgarh (SH: Construction of two room for transformers)	CPWD	3	5	8	99		0	0				0	0.17

306	ITBP	Haryana	Construction of National Dog Training Centre (kitchen, cook house, grooming shed, hospital & development work.) at Bhanu, Haryana	CPWD	0	14	6	236		0	0				0	0
307	ITBP	Haryana	Construction of road up to firing range at Bhanu, Haryana	CPWD	5	6	0	73		0	0				0	0.87
308	ITBP	Haryana	Renovation of GOs mess at Bn. HQ at Bhanu, Haryana	CPWD	2	0	0	69		0	0				0	1.19
309	ITBP	Punjab	Construction of administration block (double story) at TPT Bn. Chandigarh	CPWD	6	3	11	1.87		0	0				0	0
310	ITBP	Jammu & Kashmir	Construction of SOs mess and dormitory	CPWD	9	0	13	496	3	9.06	0	8	30 to 560	52		0
311	ITBP	Haryana	Providing air conditioners in training block (Millennium buildings) BTC	CPWD	4	21	0	102		0	0				0	0
312	SSB	Himachal Pradesh	Construction of boundary wall, Sapri, Himachal Pradesh	CPWD	3	1	2	87		0	0				0	0
313	SSB	Himachal Pradesh	Construction of indoor shooting range at TC SSB, Shamshi, Kullu, Himachal Pradesh	CPWD	23	3	0	273		0	0				0	0
314	SSB	Himachal Pradesh	External water supply scheme for SSB TC Sarahan including construction of sedimentation, filtration and storage tank and development of site.	CPWD	3	8	2	119		0	0				0	0
315	BSF	Jammu & Kashmir	Construction of airbase with cabin/hanger	CPWD	1	4	13	486		0	0	19	34 to 524	347		0
316	BSF	Jammu & Kashmir	Construction of administration block & common block at Ftr. HQ Sgr	JKPCC	4	35	0	1293		0	0				0	0
317	BSF	Haryana	Construction of 01 No 120 men barrack including information & recreation centre for reserve Bn. BSF campus Bhondsi	NBCC	1	6	0	500		0	0				0	0
318	BSF	Haryana	Construction of 01 No 120 men barrack including information & recreation centre for reserve Bn. BSF campus Bhondsi	NBCC	1	6	0	500		0	0				0	0
319	BSF	Punjab	Construction of conference cum dining hall with kitchen, dormitory with toilets block gents & ladies toilets (Attari, Amritsar)	CPWD	56	9	0	2398		0	0				0	0
320	CRPF	Delhi	Construction of administration & training block at Group Centre Kadarapur	CPWD	18	17	13	1,100	71	80.61	1	7.54	112	30 to 2139	11.8	0
321	CRPF	Punjab	Construction of Type II/126 nos. (T/S) Family quarter, Jalandhar	CPWD	7	6	5	1157		0	0				0	0
322	CRPF	Jammu & Kashmir	Construction of 60 nos. family quarters (Type-III, 22, Type-IV, 24, Type-V, 12)	CPWD	4	5	13	1633		0	0				0	0
323	CRPF	Haryana	Construction of 160 nos. Type-II family quarters at Group Centre Sonipat	NBCC	0	6	2	2571		0	0				0	0

324	CRPF	Haryana	Construction of 236 nos. various Type (Type/II-160, Type/III-38, Type-IV-24, Type/V-14)	NBCC	0	8	3	4502		0	0			0	0	
325	CRPF	Haryana	Construction of GOs mess/suites and SOs mess/ dormitory at Group Centre Bahalgarh, Sonipat	NBCC	0	8	2	871		0	0			0	0	
326	CRPF	Haryana	Construction of boundary wall, main gate with signage & automatic boom barrier and watch tower at Group Centre CRPF Bahalgarh, Sonipat, Haryana	NBCC	0	8	2	642		0	0			0	0	
327	CRPF	Haryana	Construction of 240 nos. various Type Type-II quarters at Group Centre Sonipat	NBCC	0	10	2	3858		0	0			0	0	
328	CRPF	Haryana	Construction of mens club, canteen & badministration inton court, MT garage, works shop, parade ground, fort wall, 10 bedded hospital, Dhobi Ghat, FWC and School at Group Centre Sonipat, Haryana	NBCC	0	10	2	1589		0	0			0	0	
329	CRPF	Haryana	Carrying out development and bulk services (Civil & Electrical ) works at Group Centre Sonipat, Haryana	NBCC	0	11	7	2509		0	0			0	0	
330	ITBP	Jammu & Kashmir	Construction of 03 nos. administration block one each for 12	CPWD	9	3	8	524		0	0			0	0	
331	ITBP	Jammu & Kashmir	Construction of Training shed (revised sanction)	CPWD	1	5	31	851	5	12.34	3	183.7	31	30 to 1861	150	0
332	ITBP	Jammu & Kashmir	Construction of 36 No T-II quarters for ITBP at BHQ	CPWD	7	12	13	4.83	3	6.13	0	12	30 to 662	7	0	
333	BSF	Kerala	Construction of 22 nos. temporary shed and 3 nos. toilet block at new station, Calicut	CPWD	1	4	5	494.67		0	0			0	0	
334	BSF	Kerala	Construction of BSF campus at Kainoor, Thrissur, Construction of administration block	CPWD	2	1	8	340.89	19	4.42	0			0	0	
335	BSF	Kerala	Construction for establishment of Sector HQ and SO's mess for BSF, Trivandrum	CPWD	0	0	14	348.13	1	14.32	0			0	0	
336	BSF	Kerala	Construction of administration block & GOs mess of Sector HQ for BSF, Trivandrum	CPWD	0	0	14	496.4		0	0			0	0	
337	BSF	Kerala	Construction of establishment and administration block of Sector HQ for BSF, Trivandrum	CPWD	0	0	17	161.61	1	1.25	0			0	0	
338	CISF	Tamil Nadu	Construction of semi permanent structures, 2 nos. dining & kitchen block, 1 no trade single men shop, 1 no office and bulk services	CPWD	NA	NA	0	238.67		0	0			0	0	
339	CISF	Tamil Nadu	Construction of quarter guard at 4th RB Sivagangai, Tamil Nadu	NBCC	0	0	3	218.84		0	0			0	0	
340	CISF	Tamil Nadu	Construction of 100 MTr baffle range at Regional Training Centre, Arakkonam	CPWD	2	2	5	217.68		0	0			0	0	
341	CISF	Tamil Nadu	Construction of Men's club at Regional Training Centre, Arakkonam, Tamil Nadu	CPWD	10	15	3	37.58		0	0			0	0	

342	CISF	Tamil Nadu	Providing fly proof shutters for the residential quarters (53 nos.of Type-I & 160 no.s of Type-II ) for CISF Regional Training Centre (A)	CPWD	1	6	1	379								0	0	0	0		
343	ITBP	Tamil Nadu	Construction of accommodation for various utilities at Idayapatti, Madurai, Tamil Nadu	CPWD	1	1	3	1358.46								0	0	0	0		
344	CRPF	Tamil Nadu	Construction of 149 nos. Type/II Family quarters at Group Centre Avadi	CPWD	0	0	6	279								0	0	0	0		
345	ITBP	Odisha	Construction of quarter guard & quarter master store at Sector HQ(BBSR)	CPWD	NA	NA	0	213								0	0	0	0		
346	ITBP	Odisha	Construction of main road in compus at Sector HQ (BBSR)	CPWD	NA	NA	0	139.88								0	0	0	0		
347	ITBP	Odisha	Development of site, external water supply (Phase-I) over head tank and under ground sump of 02 lacs ltrs capacity each two nos. deep tube well at 41st Bn. ITBP in Odisha	CPWD	NA	NA	0	492								0	0	0	0		
348	ITBP	Odisha	Construction of internal road and storm water drainage at 41st Bn., Bhubeneshwar	CPWD	NA	NA	0	708								0	0	0	0		
349	BSF	Telangana	Construction of 2 No's 120 men barracks	CPWD	0	5	0	980.73								0	0	0	0		
350	ITBP	Odisha	Construction of 77 residential quarters for CISF Regional Training Centre, Mundali	CPWD	NA	NA	0	523								0	0	0	0		
351	CRPF	Telangana	Construction of 2 nos. 180 men barracks for CRPF in Telangana	CPWD	1	3	2	3121.28	14	4.03	8	6.66						0	0		
352	CRPF	Odisha	Construction of 269 nos. family quarters (Type/II-227, III-27, IV-14 & V-1) for 202 COBRA Bn., Koraput	CPWD	NA	NA	0	500								0	0	0	0		
353	CRPF	Odisha	Construction of 20 bedded hospital for 202 COBRA Bn., Koraput, Odisha	CPWD	NA	NA	0	762								0	0	0	0		
354	CRPF	Odisha	Upgradation of 40 to 50 bedded hospital at Group Centre, Bhubaneshwar, Odisha	CPWD	NA	NA	0	992								0	0	0	0		
355	CRPF	Odisha	Construction of administration block /quarter guard/store block/trade single men shop for 202 COBRA Bn. Koraput, Odisha	CPWD	NA	NA	0	150								0	0	0	0		
356	BSF	Bihar	Construction of 10 nos. additional suits for combined officers mess at BSF campus	CPWD	1	4	3	249	35	0.21	6	0.02	2	66 to 400	0.32				0		
357	BSF	Bihar	Construction of 400 meter track with pavilion & change room for Sector HQ BSF Khagra,	CPWD	33	8	9	155	28	0.51	4	0.1	61	33 to 825	0.39				0		
358	BSF	Bihar	Construction of combined drill shed cum darbar shed for 142 Bn., hq at BSF campus	CPWD	3	9	6	498.58	29	0.13	4	0.01	64	30 to 1700	0.38				0		
359	ITBP	Jharkhand	Construction of administration block for Signal Training Centre, BSF, Hazaribagh	CPWD	2	3	8	447								0	0	0	0		
360	BSF	Uttar Pradesh	Construction of GOs mess with 07 suites and SOs with 04 suites for Bn. HQ. BSF Campus, Mathura, Uttar Pradesh	NBCC	0	2	2	457								0	0	36	247	0.62	0



361	BSF	Uttar Pradesh	Extrenal development works & bulk services (road work/boundary wall/entrance gateway & dormitory block) for BSF campus Mathura, Uttar Pradesh	NBCC	2	1	2	475		0	0	5	82	0.66	0	
362	BSF	Uttar Pradesh	Construction of 90 men barrack at Sector HQ, BSF, Greater Noida, Uttar Pradesh	NBCC	4	2	2	243		0	0	2	32	0.02	0	
363	CRPF	Bihar	Construction of 8 nos. SP barracks at Regional Training Centre-V, Rajgir, Bihar	CPWD	0	2	5	448.44	42	0.3	11	0.23	19	37 to 1148	0.61	0
364	ITBP	Jharkhand	Construction of M.T workshop/garage for 209, cobra Bn.Fudi, Khunti, Jharkhand	CPWD	1	9	3	149		0	0			0	0	
365	ITBP	Uttra Khand	Construction of residential cum office complex at Mana, Uttra Khand	CPWD	14	1	12	439	27	0.07	8	0.27	99	620	0.3	0.85
366	ITBP	Uttra Khand	Construction of administration block and training block at M & SI Auli Uttra Khand	CPWD	9	2	16	149	48	0.21	4	0.07	89	538	1.58	4.11
367	ITBP	Uttra Khand	development of storm water system & drains at 12 th Bn. Matli Uttra Khand	CPWD	4	8	9	293	7	0.09		0	40	1180	0.96	0
368	ITBP	Uttra Khand	Construction of administration block for 1 <sup>st</sup> Bn. Uttra Khand	CPWD	8	5	15	278	29	0.24		0	101	1650	0.96	2.73
369	ITBP	Uttra Khand	Construction of quarter guard in Astel Estate of ITBP Academy Massoorie Dehradun Uttra Khand	CPWD	4	4	2	89	22	0.1	3	0.07	56	1199	0.51	2.44
										0	0			0	0	
370	ITBP	Uttra Khand	Construction of 8 nos. T-II (D/S) quarters. At Gothi Uttra Khand	CPWD	2	3	11	63	13	0.01		0			0	0.83
371	ITBP	Uttra Khand	Augmentation of water supply line at Seemadwar Dehradun (Revised) Uttra Khand	CPWD	0	0	0	142	12	0.03		0	11	100	0.3	0.68
372	ITBP	Uttra Khand	Construction of chain link fencing in remaining area of 30 <sup>th</sup> Bn. HQ Uttra Khand	CPWD	4	1	3	85	28	0.29	4	0.01	2	97	0.07	1.81
373	ITBP	Uttra Khand	Water supply and drainage system Jalagam Parisar at Gaucher Uttra Khand	CPWD	4	1	3	77		0	0			0	0.89	
374	ITBP	Uttra Khand	Construction of GOs mess at Munsyari, Uttra Khand	CPWD	5	3	13	136	18	0.03		0			0	0
375	ITBP	Uttra Khand	Construction of officer mess at Auli, Uttra Khand	CPWD	4	1	13	273	85	0.09	4	0.06	113	1200	0.89	1.8
376	ITBP	Jharkhand	Providing & installation of substation equipment, 125 KVA, DG set and laying 11 KV hot line for 40th Bn. Ranchi, Jharkhand	CPWD	0	0	0	401		0	0			0	0	
										0	0			0	0	
377	ITBP	Uttra Khand	Construction of quarter master store at 36th Bn. Lohaghat	CPWD	4	2	7	223.43	2	0.04		0			0	0
378	ITBP	Jharkhand	Construction of SOs mess at Ranchi, Jharkhand , 40th Bn. Jharkhand	CPWD	1	1	6	2493.59	22	6.32	2	0.63	94	30 to 100	44.6	0
379	ITBP	Jharkhand	Construction of bituminous road and drain for non residential buildings at 40th Bn., ITBP Ranchi, Jharkhand	CPWD	2	4	4	456.35		0	0				0	0
380	SSB	Bihar	Construction of boundary wall at Bathnaha, Araria, Bihar.	CPWD	5	3	4	444.76	5	0.3	5	0.01			0	0

381	SSB	Bihar	Construction of border out post building at comany HQ. cum border out post at Sikta under Bn. HQ. SSB, Narkatiaganj, Bihar	CPWD	0	0	8	444.14							0	0			0	0
382	SSB	Bihar	Construction of border out post building at company HQ. cum border out post at Pantoka under Bn. HQ. SSB, Piprakothi, East Champaran, Bihar	CPWD	3	6	9	476.93	49	0.14		0							0	0
383	SSB	Bihar	Construction of 128 Men Barrack at SSB Bn. head quarters, Bathnaha, Distt. Araria, Bihar.	CPWD	1	11	5	374	3	0.01		0							0	0
384	SSB	Uttar Pradesh	Construction of permanent infrastructure border out post Khunwa Bn. HQ. Maharajganj, Uttar Pradesh	CPWD	16	4	6	434		0	0	0	7	563	0.11					0
385	SSB	Uttar Pradesh	Construction of permanent infrastructure border out post Chandithan Bn. HQ Maharajganj, Uttar Pradesh	CPWD	17	3	7	378	4	0.01		0							0	0
386	SSB	Uttar Pradesh	Construction of permanent infrastructure border out post Jhingti Bn. HQ Maharajganj, Uttar Pradesh	CPWD	18	6	9	422	2	0.1		0	23	1083	0.18					0
387	SSB	Uttar Pradesh	Construction of permanent infrastructure border out post Dandahead Bn. HQ Maharajganj, Uttar Pradesh	CPWD	14	5	31	317		0	0								0	0
388	SSB	Uttar Pradesh	Construction of permanent infrastructure border out post Dranoura Bn. HQ Siddharth Nagar, Uttar Pradesh	CPWD	17	3	9	287	1	0.01		0	8	300	0.07					0
389	SSB	Uttar Pradesh	Construction of permanent infrastructure border out post Pakrihawa Bn. HQ Siddharth Nagar, Uttar Pradesh	CPWD	17	2	29	382		0	0	0	3	378	0.07					0
390	SSB	Uttar Pradesh	Construction of permanent infrastructure border out post Aligarwa Bn. HQ Siddharth Nagar, Uttar Pradesh	CPWD	17	3	23	322		0	0								0	0
391	SSB	Uttar Pradesh	Construction of permanent infrastructure border out post Lohti Bn. HQ Siddharth Nagar, Uttar Pradesh	CPWD	16	3	18	375		0	0	0	11	325	0.08					0
392	SSB	Uttar Pradesh	Construction of permanent infrastructure border out post Harbanspur Bn. HQ Siddharth Nagar, Uttar Pradesh	CPWD	11	2	25	453		0	0	0	3	556	0.02					0
393	SSB	Uttar Pradesh	Construction of permanent infrastructure border out post Barhani Bn. HQ. Sidharthnagar, Uttar Pradesh	CPWD	16	3	25	212		0	0								0	0
394	SSB	Uttar Pradesh	Development & bulk services for Frontier HQ, SSB at Gomti Nagar, Lucknow	CPWD	15	2	3	425	12	0.1	2	0.01	37	34	0.24					0
395	SSB	Uttar Pradesh	Construction of 10 beded hospital at Palia, Uttar Pradesh	CPWD	0	11	4	222	29	0.07		0	47	100 to 250	0.79					0
396	SSB	Uttra Khand	Construction of permanent infrastructure including development of site and rain water harvesting at border out post-Bagrihat	CPWD	4	9	11	120		0	0								0	0
397	SSB	Bihar	Construction of Family welfate centre at SSB Campus Narkatiyaganj, Bihar	CPWD	4	2	0	427		0	0								0	0
398	SSB	Uttar Pradesh	Construction of 128 men barrack at Bn. HQ SSB Balrampur, Uttar Pradesh	CPWD	40	21	8	139		0	0								0	0

399	SSB	Uttra Khand	Renovation and upgradation of existing internal road at FHQ Ranikhet, Uttra Khand	CPWD	5	5	4	951	8	0.05		0	1	4678	0.44	0
400	BSF	Uttar Pradesh	Constructions of one number 240 men barrack for Bn. HQ BS Campus at Mathura.	NBCC	1	3	4	1207		0	0	0	8	352	0.62	0
401	ITBP	Jharkhand	Construction of dog training school for CISF 2nd Resrve Bn., Ranchi, Jharkhand	NBCC	0	0	0	1252		0	0				0	0
402	CRPF	Uttar Pradesh	Construction of 50 bedded hospital at Group Centre, Allahabad, Uttar Pradesh	CPWD	12	5	9	2403	22	0.12		0	43	41	0.07	0
403	CRPF	Uttra Khand	Construction of administration building etc.	NBCC	10	1	2	2002	52	0.88	9	0.49			0	0
404	CRPF	Jharkhand	Construction of 3 nos. 240 mem Barrack for 203, COBRA Bn., Barhi, Hazaribagh	CPWD	4	2	8	2101		0	0				0	0
405	CRPF	Uttra Khand	Construction of 3 nos. 240 mens barracks	NBCC	10	5	2	3128	26	0.01	2	0.11			0	0
406	CRPF	Uttra Khand	Construction of carrying out development & bulk services	NBCC	19	22	3	1638	28	0.03	3	0.05			0	0
407	CRPF	Uttra Khand	Construction of 144 nos. Type-II quarters	NBCC	41	1	2	1002.91	2	0.04	6	0.21			0	0
408	ITBP	Jharkhand	Construction of combined building/ administration/quarter guard/store block for 209 COBRA Bn. Fudi, Khunti, Jharkhand	CPWD	0	0	6	1311.11		0	0				0	0
409	ITBP	Jharkhand	Construction of internal peripheral and other road to connect plots ABC&D, surface, drain culverts and retaining wall for 209 cobra Bn. Fudi, Khunti, Jharkhand	CPWD	1	6	5	3703	1	24.96		0			0	0
410	ITBP	Uttra Khand	Construction of seprated family accomodation at ITBP Seemadwar Dehradun. Sub Head: Construction of 200 nos. Type-I, 144 nos. Type-II and 24 nos. Type-III quarters; construction of sewage treatment plant, construction of overhead tank and drilling of tubewell	CPWD	1	5	56	582	CPWD	186	0.82	16	0.19	320	0.8	16.61
411	ITBP	Uttar Pradesh	Construction of boundary wall, road, sentry post including front gate & front wall and dormitory block with attached toilet at Greater Noida, Uttar Pradesh	CPWD	0	8	10	511.82	26	0.4		0	3	21600	0.9	0
412	SSB	Bihar	Construction of Type-III-24 nos., Type-IV-6 nos. & Type-V-2 nos. for SSB at Narkatia Ganj, Bihar	CPWD	2	1	12	540.38	30	0.58		0			0	0
413	SSB	Bihar	Construction of 10 bedded hospital at 12th Battalion HQ, Bagha, Valmiki Nagar, Bihar.	CPWD	11	10	14	671.68	3	0.14		0			0	0
414	SSB	Bihar	Construction of 53 nos. Type-II quarters at Sector Head quarter for SSB, Muzaffarpur, Bihar	CPWD	8	6	17	1585.9	5	0.2		0			0	0
415	SSB	Bihar	Development of site & bulk services for SSB at Narkatiaganj, Bihar	CPWD	3	7	17	1585.9	9	0.05		0			0	0
416	SSB	Bihar	Construction of boundary wall for Sector HQrs, SSB, Muzaffarpur, Bihar	CPWD	8	2	5	238.33	16	0.11		0	4	43 to 86	0.09	0

417	SSB	Uttar Pradesh	Construction of administration Block at Ftr. Lucknow, Uttar Pradesh	CPWD	18	9	2	2277	3	0.04		0			0	0
418	AR	Assam	Construction of 03 single men barrack with allied services and development works for AR at Diphu, Assam	NPCCCL	3	1	3	429.06		0		0			0	0
419	AR	Tripura	Construction of 08 nos. single junior commissioned officers accommodation (G+I), 02 Blocks of 06 nos. single men barrack (G+II), one no. administration block, 01 no. officers mess, one no. junior commissioned officers club and internal road for 36 AR at Radhanagar, Tripura	NPCCCL	4	12	2	755.85		0	1	2.7			0	0
420	AR	Manipur	Construction of 06 nos. Type III (G+II) and 48 nos. Type II quarters. (G+II) for 19 AR at Shangshak, Manipur	NPCCCL	3	4	4	528.13	4	1.07		0			0	0
421	AR	Tripura	Construction of 02 nos. T-V (G+I) 02 nos. T-IV (G+I) 12 nos. T-III 90 nos. T-II (G+II) and 06 nos. single officers accommodation for 36 AR at Radhanagar	NPCCCL	4	12	2	1,196.11		0	0	0	6	100 to 44	51.9	0
422	AR	Tripura	Construction of 06 nos. T-III (G+II) & 78 nos. T-II (G+II) for 15 AR at Teliamura	NPCCCL	5	11	7	854.31	12	32.27		0	10	100 to 421	24.6	0
423	AR	Assam	Construction of 12 nos. T-III (G+II) and 54 nos. T-II G+II quarter for 43 AR at Lokra (Assam)	EPIL	4	6	4	587.46		0		0			0	0
424	AR	Assam	Construction of 09 nos. single men barrack (G+II), 01 No administration block (G+I) and 01 No officers mess for 43 AR at Lokra, Assam	EPIL	#E	20	3	552.16		0		0			0	0
425	AR	Nagaland	Construction of 01 nos. Type IV quarters (GF), 06 nos. Type III quarters. (G+II) and 06 nos. single officers living accommodation (G+I)	NPCCCL	6	0	14	658.65		0		0			0	0
426	AR	Assam	Construction of 48 nos. T-II quarters and 12 nos. T-III seperated family accommodation for Assam Rifles at Jorhat	EPIL	1	5	5	611.34		0		0			0	0
427	AR	Arunachal Pradesh	Construction of 02 Type-V (G+I) quarters, 72 nos. Type-II quarters (G+II) and 04 nos. single officers living accommodation (G+I) for 29 Assam Rifles at Jairampur, Arunachal Pradesh	EPIL	6	1	9	773.69		0		0			0	0
428	AR	Nagaland	Construction of 03 block of 09 nos. single men barrack (for 18 NCOs and 180 Ors) (G+III), 01 no. administration block, 01 officers mess, 01 no. junior commissioned officers	NPCCCL	6	2	12	704.48	5	4.36		0			0	0
429	AR	Mizoram	Construction of 48 nos. Type-II and 06 nos. Type-III quarters for Assam Rifles at Lunglie, Mizoram	EPIL	5	11	0	674.07		0	0	0	4	100 to 832	44.3	0
430	CRPF	Assam	Providing and fixing wire gauge shutters in residential and non-residential building 344 nos. T/I quarters, 16 nos. T/II quarters. & 7 nos. barracks	CPWD	13	13	8	94.8	5	20.21		0			0	0
431	CRPF	Assam	Construction of 33 KV sub station & electric sub station rooms at training area & gate No.3	CPWD	16	3	8	164.87	18	16.25	1	0.23	143	100	75.7	0

432	CRPF	Tripura	Construction boundary wall with two main gates, watch towers 6 nos., sentry posts 18 nos. & guard room	CPWD	0	19	8	328.65	20	23.58		0	51	(-)100 to 1111	107	0
433	CRPF	Tripura	Construction 26 nos. family quarters (T/II-18, T/III-6 & T/IV-2)	CPWD	17	4	6	411.55	27	10.51	1	0.31	83	(-)100 to 318	113	0
434	BSF	West Bengal	Construction of residential quarter at Seema Nagar SH: 91 nos. Type-II quarter.	CPWD	#E!	#VAL UE	14	1,117.05	65	40.34	24	7.52	163	31 to 458	131..5	0
435	BSF	Meghalaya	Construction of combined amenity/community centre for Sector HQ BSF, Umpling Shillong	CPWD	3	6	5	234.9	9	0.94		0	8	(-)100 to 115	10	0
436	ITBP	Arunachal Pradesh	Construction of deep bore well (i) 02 nos. for 9th Bn. Lohitpur. (ii) 01 No. for 25 Bn. ITBP, Tezu, Arunachal Pradesh	CPWD	4	2	5	59.06	3	1.21		0	1	-98	0.71	0
437	CRPF	Maharashtra	Construction of 38 nos. family quarters ( T/I-4, T-II-12, T-III, T-IV-12 & T-V-2)	CPWD	0	7	4	335		0		0			0	0
438	CRPF	Maharashtra	399 nos.Type-I 60 nos. quarters	CPWD	0	0	18	1838.34	64	13.11	19	4.5	188	(-)100 to 100	109	14.56
439	CRPF	Maharashtra	Construction of 2 nos. filter bed and clear water reinforced cement concrete storage tank of 2.50 lakhs litre capacity	CPWD	11	11	10	98.89	5	2.47		0			0	0.64
440	CRPF	Maharashtra	359 nos. (T/I-93, T-II-255, T-III-7& T-IV-4 nos.) family quarters (Construction of 18 nos.Type-I quarters)	CPWD	NA	NA	0	1764.32		0		0			0	18.47
441	CRPF	Maharashtra	Construction of 3 nos. 120 men barracks	CPWD	6	6	15	599.47		0		0			0	5.88
442	AR	Delhi	Construction of 32 nos. Type-II, 16 nos. Type-III separated family quarters and hostel for 30 boys and 20 girls for Assam Rifles at Dwarka, New Delhi	EPIL	0	5	33	481		0		0			0	0
443	CRPF	Delhi	Augmentation of 3 No. electric sub station	CPWD	10	14	7	187		0		0			0	0
444	CRPF	Delhi	Laying of C.I. pipeline at Group Centre, CRPF, Nazafgarh, New Delhi	CPWD	0	15	32	833	9	1.6		0	24	31 to 8701	0.49	4.88
445	CRPF	Delhi	Construction of boundry wall Wazirabad, New Delhi	CPWD	24	0	9	217	40	10.48		0	13	(-)43 to 66	83.2	0.09
446	CRPF	Delhi	Construction of Type-II, 288 Family quarter. Greater Noida, Uttar Pradesh	NBCC	16	9	2	1411		0		0			0	0
447	CRPF	Delhi	Construction of 240 Men barracks, Greater Noida, Uttar Pradesh	NBCC	25	2	10	1448		0		0			0	0
448	NSG	Delhi	Construction of indoor shooting range at NSG, Manesar	CCPCPWD CWD	7	20	19	220	34	12.6		0	12	36 to 240	45.7	1.77
449	CISF	Madhya Pradesh	Construction of 4 nos. drill sheds for Regional Training Centre, Barwaha	CPWD	14	1	11	142	10	2.29	3	0.15			0	0
450	CRPF	Chhattisgarh	Construction of 6 nos. semi permanent buildings (22 x 8.5 MTrs) having AC sheet roofing)	CPWD	5	4	4	98.42	5	1.95		0	51	(-)100 to 531	3.17	0

451	CRPF	Madhya Pradesh	Construction of administration block, CRPF Bangrasiya, Bhopal	CPWD	6	1	5	161.92	15	3.85	1	0.17			0	0
452	CRPF	Madhya Pradesh	Repair and renovation of GOs mess	CPWD	14	4	8	82.95	62	16.02	17	1.26			0	0
453	CRPF	Madhya Pradesh	Construction of boundary wall at Group Centre, CRPF, Neemcuh, Madhya Pradesh	CPWD	1	27	15	496.78	35		8	4				
												0				
												9				
												5				
454	CRPF	Madhya Pradesh	Construction of 501 nos. T/II family quarters at Group Centre Neemuch	CPWD	2	8	57	4657.93	133	63.35	4	4.58			0	0
										0		0			0	0
455	BSF	Madhya Pradesh	Construction of 120 nos. separated family accommodation (SFA) quarter at Bijasan under Central School of Weapons and Tactics (CSWT) BSF, Indore	CPWD	2	8	11	482.33	32	17.91	11	7.32			0	0
456	CISF	Rajasthan	Construction of 02 nos. of 180 men barracks	CPWD	2	6	8	499.49	37	12.16	6	69.49	41	(-)100 to 983	77.9	0
457	CISF	Rajasthan	Construction of 107 quarters (T-II 84, T-III 20, T-IV 02 and T-V 01) for Regional Training Centre, Rajasthan	CPWD	1	7	8	857.02	33	43.04	16	10.14	20	(-)100 to 200	147	0
458	CISF	Rajasthan	Construction of non-residential buildings	CPWD	4	4	7	1078.4	87	1.39	5	84.4			0	0
459	CISF	Rajasthan	Construction of family welfare centre	CPWD	8	1	10	180.52	4	2.26	6	20.69	24	(-)100 to 600	15.4	0
460	CRPF	Gujarat	Construction of 60 women barrack	CPWD	36	76	4	94.65	28	3.68		0	1	1300	1.29	0
461	CRPF	Gujarat	Construction of under ground sump & providing & laying water supply line for storage & distribution of Narmada Water	CPWD	0	9	4	98.6	5	0.61		0	1	50	0.09	0
462	CRPF	Gujarat	Providing & fixing of sewerage treatment plant	CPWD	3	13	19	84.31		0		0			0	0
463	CRPF	Rajasthan	Providing & fixing wire mesh doors & windows in 386 nos. various Types of old family quarters (T/I-84, T/II-290 & T/III-12)	CPWD	4	14	5	98.97	10	11.3		0	50	(-)100 to 50	68.1	0
464	CRPF	Delhi	Development and bulk services at Group Centre, CRPF, Kadarpur, Haryana	CPWD	0	3	14	2502	9	83.57		0	11	47 to 339	52.8	5.06
465	CRPF	Delhi	Construction of approach road to connect Group Centre from main village road Kadarpur, Haryana	CPWD	25	24	3	65.29	3	10.74	1	0.01	6	52 to 117	3.93	0.78
466	CRPF	Delhi	Construction of 699 quarters at Group Centre, Kadarpur, Haryana	CPWD	1	6	14	3106	16	3.89		0	148	(-) 100	275	0

467	CRPF	Haryana	Construction of compound wall on western side & raising height of about 2100 MTrs length of existing boundry wall	CPWD	0	2	10	117.09		0	0			0	0	
468	CRPF	Jammu & Kashmir	Construction of 117 nos. family quarters	CPWD	5	2	62	396	12	6.02	0	52	30 to 547	28.5	0	
469	CRPF	Jammu & Kashmir	Construction of 3 nos. 180 men barracks	CPWD	16	6	7	873	4	11.58	0	55	30 to 1075	34.4	8.02	
470	CRPF	Jammu & Kashmir	Construction of 04 nos. Nallah RCC sumpwell services administration & quarter guard	CPWD	25	15	28	918.47	44	19.77	5	9.78	40	30 to 1100	37.2	6.5
471	CRPF	Jammu & Kashmir	Construction of under ground water sump, lines and providing CGI sheet roofing	CPWD	2	3	7	74.35		0	0			0	0	
472	CRPF	Punjab	Construction of compounding wallat Hira Nagar, Punjab	CPWD	0	0	0	63.98		0	0			0	0.56	
473	CRPF	Jammu & Kashmir	Construction of boundary wall at CRPF Nagrota, Jammu & Kashmir	CPWD	2	6	23	185.9	1	12.64	0	2	102 to 3522	0.68	0.75	
474	CRPF	Punjab	Construction of approach road, water supply & sewage disposal for 180 men barrack Hallomajra, Punjab	CPWD	0	0	6	177		0	0			0	0.65	
475	BSF	Jammu & Kashmir	Construction of boundary wall with barbed wire fencing at Ftr. HQ, BSF Baramulla	CPWD	11	0	5	129.3		0	0			0	0	
476	ITBP	Haryana	Construction of road up to firing range at ITBP, BTC, Haryana	CPWD	0	0	0	187		0	0			0	0.04	
477	ITBP	Jammu & Kashmir	Construction of 120 men barrack at 21st Bn. Jammu & Kashmir	CPWD	2	0	21	73.2	21	8.16	8	4.51	11	30 to 423	1.47	2.78
478	CISF	Tamil Nadu	Indoor sports complex for Regional Training Centre, Tamil Nadu	CPWD	0	0	0	329.15		0	0			0	0	
479	CRPF	Kerala	Development & bulck service at Regional Training Centre III, Peringome, Kannur	CPWD	0	0	10	1543.58		0	0			0	0	
480	CRPF	Tamil Nadu	Construction of 180 men barrack in Tamil Nadu	CPWD	0	0	14	964.75		0	0			0	0	
481	CRPF	Tamil Nadu	Providing bulk services and development works	CPWD	0	8	0	475.41		0	0			0	0	
482	CRPF	Tamil Nadu	Revised sanction issued for Construction of boundary wall with barbed wire fencing for additional area obtained after re-survey in Tamil Nadu	CPWD	1	2	4	218.84		0	0			0	0	
483	CRPF	Tamil Nadu	Constructionof firing range at CRPF campus Tamil Nadu	CPWD	4	9	3	160.23		0	0			0	0	
484	CRPF	Tamil Nadu	Constructionof trainee hostel for 50 mahila SOs	CPWD	2	4	8	325.9		0	0			0	0	
485	CRPF	Tamil Nadu	Constructionof recreation hall at CRPF campus, Tamil Nadu	CPWD	13	2	7	95.42		0	0			0	0	
486	CRPF	Tamil Nadu	Providing mosquito proof door shutter in 4 nos. 60 men barracks, SOs dormitory & 60 women barrack	CPWD	2	7	7	96.78		0	0			0	0	
487	CRPF	Kerala	Replacement of over head electric lines with under ground cables at Group Centre, CRPF, Pallipuram, Trivandrum	CPWD	5	38	15	69.54	2	9.21	2	3.21			0	0

488	CISF	Odisha	Construction of ten bedded hospital for Regional Training Centre in Odisha	CPWD	NA	NA	0	120			0	0			0	0
489	CISF	Odisha	Construction of 5 quarters (Type-V 01 and Type-IV 04) for Regional Training Centre	CPWD	NA	NA	0	70.73			0	0			0	0
490	CISF	Odisha	Widening of firing range of Regional Training Centre in Odisha	CPWD	NA	NA	0	71.19			0	0			0	0
491	CISF	Odisha	Construction of fort wall for Regional Training Centre in Odisha	CPWD	NA	NA	0	87.87			0	0			0	0
492	CISF	Telangana	Construction of fire exercise ground with demonstration wall and rooms for FSTI, CISF, Hakimpet, Hyderabad.	CPWD	29	0	12	159	15	4.08	8	6.66			0	0
493	CRPF	Telangana	Construction of. 312 nos. family quarter for CRPF in Telangana	CPWD	1	21	29	1947		0	0			0	0	
										0	0			0	0	
494	CRPF	Telangana	Construction of 180 nos.Type-II quarters (Part-I & Part -II) Group Centre, CRPF Hyderabad	CPWD	0	1	8	989.93	23	10.91	4	0.96	18	30	35	0
495	CRPF	Telangana	Construction of sewerage treatment plant- laying of CI pipe line grid for horticulture purpose	CPWD	0	0	26	44.33		0	0				0	0
496	CRPF	Telangana	Construction of 248 nos. family quarters (Type-II-240 nos. and Type-III 8 nos.) for Group Centre. Jawaharnagar, Hyderabad.	CPWD	3	0	4	1445	46	21.26	14	0.56			0	0
497	CRPF	Odisha	Construction of 115 nos. family quarters T-II-97, T-III-14, T-IV-4 nos.	CPWD	NA	NA	0	588.53		0	0				0	0
498	CRPF	Bihar	Construction of administration block Group Centre, Muzaffarpur, Bihar	CPWD	10	10	17	161.08		0	2	0.14			0	0
499	CRPF	Bihar	Construction of 4 nos. 180 men barrack Group Centre, Muzaffarpur, Bihar	CPWD	4	10	90	1346.66		0	2	13.19			0	0
500	CRPF	Bihar	Construction of 23 nos. family quarters (T-I-2, T-II-12, T-III-7, T-VI-2), bulk services, main gate, guard room, development works and boundary wall at Sector HQ, Patna, Bihar	CPWD	0	0	0	361.36	10	0.04	0	140	31 to 1739	0.07		0
501	CRPF	Bihar	Construction of administration block for IGP /DIGP Office, Sector HQ, Patna, Bihar	CPWD	3	6	17	275.87	22	0.51	2	0.06	101	309 to 594	0.38	0
502	CRPF	Bihar	Construction of SOs mess & other Mess (4 storied) for IG/DIGP, CRPF at Digha Sector HQ, Patna, Bihar	CPWD	14	16	30	314	23	0.11	5	0.01	130	31 to 1600	0.95	0
503	CRPF	Bihar	Construction of 15 nos. T-I-2, T-II-7, T-III-5 & T-IV-1 at Sector HQ, Patna, Bihar	CPWD	4	13	7	104		0	0				0	0
504	ITBP	Jharkhand	Construction of 97 nos. FF/ Qrs(T/II-96,T/V-01)(External electrification work from substation to F/quarters ans installation of tube well 20.2.2009	NBCC	0	8	3	683.7		0	0				0	0



505	CRPF	Uttar Pradesh	Construction 60 women barrack for 104th Bn. RAF Aligarh	CPWD	5	18	3	88	33	0.03	6	0.01	75	44	0.18	0
506	CRPF	Uttar Pradesh	Construction of 250 nos. F/quarters (T/II-240, IV-8, V-2) Group Centre Allahabad.	CPWD	0	7	8	1809	13	0.55	1	0.04	25	44	0.92	1.19
507	CRPF	Uttar Pradesh	Construction of 20 bedded hospital for CRPF in Uttar Pradesh	CPWD	49	9	1	368	34	0.01		0	30	45	0.97	0.08
508	CRPF	Uttar Pradesh	Construction of Motor Transport (MT) Garage and Workshop at CRPF campus, Lucknow, Uttar Pradesh	CPWD	0	0	13	306	3	0.05	4	0.29	50	55	35	0
509	CRPF	Uttar Pradesh	Construction of 278 nos. (T-1-2 & T/II-266 nos.) family quarters for CRPF at Lucknow	CPWD	3	24	3	1110	44	0.38	6	0.09	84	904	0.95	0
510	CRPF	Uttar Pradesh	Construction of office of DIGP Group Centre Lucknow	CPWD	2	4	6	145	26	0.02		0	35	45	0.19	0.07
511	CRPF	Uttar Pradesh	Development & bulk services (Civil works only) Meerut	CPWD	0	0	0	569		0		0			0	0
										0		0			0	0
512	CRPF	Uttar Pradesh	Construction of 15 nos. watch lower & guard rooms Rampur, Uttar Pradesh	CPWD	1	1	3	50	16	0.05		0	43	(-)100 to 90	0.14	0
513	CRPF	Uttar Pradesh	Construction of boundry wall & 2 nos. watch towers with guard rooms & providing with concertina wire Rampur, Uttar Pradesh	CPWD	1	1	3	69	9	0.07		0	8	46	0.09	0
514	CRPF	Uttar Pradesh	Construction of Site development and bulk Services at 104th Bn. CRPF, Rapid Action Force, Aligarh, Uttar Pradesh	CPWD	4	14	73	834		0	0	0	7	33 to 124	63	0.08
515	CRPF	Uttar Pradesh	Construction of one no. 60 women barrack, 101 RAF Allahabad, Uttar Pradesh	CPWD	1	12	2	139	45	0.03		0			0	0.11
516	ITBP	Uttra Khand	Construction of 10 bedded hospital at ITBP campus Mirthi, Uttra Khand	CPWD	4	5	12	179	36	0.06		0			0	1.34
517	ITBP	Uttra Khand	Construction of quarter guard, quarter master, store and MI room at Auli, Uttra Khand	CPWD	14	2	10	401	10	0.02		0	33	312	0.19	3.36
518	SSB	Bihar	Construction of border out post building at Majorganj under 9 <sup>th</sup> Bn., Sitamarhi, Bihar	CPWD	0	0	0	489		0		0			0	0
519	SSB	Bihar	Construction of border out post at HQ Kamla in Madhubani under 9 <sup>th</sup> Bn., Jaynagar	CPWD	0	0	0	456	5	0.02		0			0	0
520	SSB	Uttra Khand	Construction of residential quarters (T/IV-02, T/I-12 nos.) at Bn. HQ Almora	CPWD	4	7	8	131		0		0			0	0
521	AR	Arunachal Pradesh	Provision of 81 MM Motor Simulator for 18 Assam Rifles at Jairampur, Arunachal Pradesh	Deptt.		2	6	55.93	4	1.07		0			0	0
522	AR	Manipur	Provision of extension of dining hall and recreation centre over RCC plateform for Training Camp Minuthong, Manipur	Deptt.	9	1	2	NA		0		0			0	0
523	AR	Mizoram	Construction of recreation room for HQ 23 Sector AR at Khatla, Aizawl, Mizoram	Deptt.	#V	#VAL UE	5	54		0		0			0	0

524	AR	Nagaland	Providing of work for family welfare centre for 26 AR at Kohima, Nagaland	Deptt.	#E!	#VAL UE	2	36.3		0	0			0	0	
525	AR	Tripura	Provision of protection for signal exchange and magazine building of 35 AR at Agartala, Tripura	Deptt.	#V!	#VAL UE	2	23.02		0	1	1.99		0	0	
526	BSF	Delhi	Construction of modular work station at BSF HQ, New Delhi	Deptt.	0	2	2	59.01		0	0			0	0.63	
527	BSF	Delhi	Construction of office accommodation for BSF staff air wing, New Delhi	Deptt.	0	1	1	58.91		0	0			0	0.64	
528	BSF	Delhi	Providing flooring tiles in corridors in BSF HQ, New Delhi	Deptt.	0	2	4	50.73		0	0			0	0.55	
529	BSF	Delhi	Renovation of Type-I quarters at BSF Chhawla, New Delhi	Deptt.	0	5	2	59.68		0	9	2.43	59	(-) 100 to 1465	19.2	0.65
530	BSF	Delhi	Renovation of Type-II quarters at BSF Chhawla, New Delhi	Deptt.	0	6	4	59.56	15	5.16	0	30	(-) 100 to 744	24.4	0.64	
531	BSF	Assam	Renovation/upgradation of 120 men barrack no. 1 (being used by Ftr. HQ) at BSF Campus, Patgaon under Ftr. HQ, BSF, Guwahati, Assam	Deptt.	9	4	1	21.08	1	0.19	0			0	0.11	
532	BSF	Gujarat	Construction of 209 nos. residential quarters for BSF Campus at Gandhidham.	CPWD	15	9	47	40.1	4	4.28	0	2	38.47	0.11	0	
533	BSF	Gujarat	Construction of 04 nos. Prefab structures for jawan barrack, single men and PC/CC Room at border out post No 5 (Near VillKosa) of 157 Bn. BSF (Marrine Bn.) under Sector HQ BSF Bhuj	Deptt.	0	0	3	30.57		0	0			0	0	
534	BSF	Gujarat	Construction of 04 nos. GOs mess in BSF campus Gujarat	Deptt.	0	0	12	32.76	13	4.7	7	2.11	35	31 to 400	4.88	0
535	BSF	Gujarat	Construction of 04 nos. Prefab structures for jawanbarrack, Rooms at border out post No 1 (Near Mitha Port Jakhau) of 157 Bn. BSF (Marrine Bn.) under Sector HQ BSF Bhuj	Deptt.	0	0	3	30.57		0	0			0	0	
536	BSF	Gujarat	Construction of 03 nos. of magazine building for 133 (now 107) Bn. BSF under Sector HQ. BSF, Gandhinagar, Gujarat	Deptt.	0	0	19	23.78	5	0.88	0	13	31 to 255	3.27	0	
537	BSF	Haryana	Construction of providing wire-mesh door/ window shutter in Type-I Qters. No. 1 to 100 at BSF Campus, Hisar, Haryana	Deptt.	0	18	2	48		0	0			0	0.45	
538	BSF	Haryana	Construction of drill shed at Bn. HQ 33 Bn. BSF, Hisar, Haryana	Deptt.	0	15	11	60		0	0			0	0.59	
539	BSF	Jammu & Kashmir	Construction of providing of security light alongwith perimeter of BSF Campus Jammu	Deptt.	0	0	10	27		0	0			0	0.25	
540	BSF	Karnataka	Construction of providing and fixing wire gauge shutters to doors and windows of existing Type-II quarters (71 numbers); Type-III (10 numbers); Type-III cottages (03 numbers) and Type-IV (07 numbers) at Signal Training Centre, BSF, Bengaluru	Deptt.	NA	NA	0	26.82	4	1.47	0			0	0.29	

541	BSF	Karnataka	Construction of 10 numbers semi permanent structures for residential and non residential accommodation for 82nd Battalion, BSF at Karahalli, Karnataka	Deptt.	NA	NA	0	59.99	6	1.36	2	1.33			0	0.58
542	BSF	Karnataka	Construction of light/medium and heavy vehicle garage for 82nd Battalion, BSF at Karahalli, Karnataka	Deptt.	NA	NA	0	59.96	4	1.79		0			0	0.66
543	BSF	Karnataka	Upgradation of existing Type-I staff quarters (120 numbers) at Signal Training Centre, Bengaluru, Karnataka	Deptt.	NA	NA	0	58.36	1	0.06	3	0.22			0	0.33
544	BSF	Kerala	Construction of 2 nos. magazine for 163 Bn. BSF, Thrissur, Kerala	Deptt.	0	0	8	45.8	5	10.29		0			0	0
545	BSF	Kerala	Construction of Type-V quarters at Sector HQ, Muttathara, Trivandrum, Kerala	Deptt.	0	0	9	49.11	19	3.37	12	2.11			0	0
546	BSF	Manipur	Construction of 5 nos. temporary structures for communication set up and MT Fleet for establishment of 140 Bn. of BSF, under Sector HQ BSF, Manipur	Deptt.	#VALUE!	#VALUE	0	36.36							0	0
547	BSF	Meghalaya	Construction of Type-II (04 nos.) quarters (double storied) at BSF Campus Umpling, Meghalaya	Deptt.		2	20	48.02	13	6.45		0	64	(-)100 to 344	8.31	6.02
548	BSF	Punjab	Construction of 4 nos. Transit Suit at BSF campus, Jaladhar, Punjab	Deptt.	0	0	0	37		0		0			0	0.36
549	BSF	Punjab	Construction of vertical extension, at BSF campus, Jalandhar, Punjab	Deptt.	0	0	0	25		0		0			0	0
550	BSF	Rajasthan	Construction of jawan barrack at border out post Vijeta, BINjour, Majnu & Kheruwala-64 Bn. BSF	Deptt.	0	14	3	57.83	15	9.41		0	10	(-)100 to 854	10.3	0
551	BSF	Rajasthan	Construction of jawan barrack, cook house cum dining hall, administration block and kote store & magazine block at border out post Jagdev of 66 Bn. BSF, Rajasthan	Deptt.	0	2	9	39.38	6	0.15		0			0	0
552	BSF	Rajasthan	Construction of administration block and single men barrack at border out post Nalka of 194 Bn. BSF under Sector HQ BSF, Jaiselmer	Deptt.	0	1	30	39.67		0		0			0	0
553	BSF	Rajasthan	Construction of improvement of Type-I (44 nos.) quarters at Ftr. HQ BSF, Rajasthan	Deptt.	0	5	5	38.96	10	1.17	2	0.16	2	(-) 100 to 260	10.8	0
554	BSF	Rajasthan	Recarpeting drill Square Parade ground at Signal Training Centre BSF, Jodhpur	Deptt.	0	2	4	47.24		0	0	0	3	-100	2.9	0
555	BSF	Tripura	Renovation/up-gradation of administration block of 19 Bn. BSF Campus, Salbagan, Sector HQ BSF, Gokulnagar	Deptt.	#V!	#VALUE	3	32.82	19	3.25		0	18	(-) 100 to 98	4.01	0.21
556	BSF	Uttra Khand	Construction of SOs accommodation (G-1) BSF campus Markham Grant-II Dehradun	CPWD	0	0	1	29		0	0	0	21	458	0.07	0
557	BSF	Uttra Khand	Construction of single SOs accommodation with pre-fabricated modular Bn. HQ Dehradun	NBCC	0	0	0	25		0		0			0	0.21

558	BSF	Uttar Pradesh	Construction of magazine building for Bn. HQ BSF, Mathura	Deptt.	0	1	5	60	1	0.01		0			0	0
559	BSF	Uttar Pradesh	Construction of perimeter fencing of BSF campus Baad, Mathura	Deptt.	0	2	4	33		0		0			0	0
560	BSF	Uttar Pradesh	Construction of 02 nos. Toilet block at 97 Bn. BSF, Lucknow.	Deptt.	1	0	6	11	1	0.1		0			0	0
561	BSF	West Bengal	Flood damage repair in BSF campus, West Bengal	CPWD	2	0	1	23.57	1	0.05		0	1	245	0.18	0
562	BSF	Maharashtra	Construction of basic infrastructure for additional Regional Training Centre like toilet block, bathing point, RO Plant, & deep tube well ) at Signal Training Centre Chakur, Maharashtra	Deptt.	0	0	3	55.61	10	0.34	16	1.56			0	0.5
563	BSF	Maharashtra	Construction of 08 nos. semi permanent structures for additional at Signal Training Centre BSF Chakur, Maharashtra	Deptt.	0	0	5	54.99		0		0			0	0.52
564	BSF	Maharashtra	Construction of Water Closet (WC) block 10 seated for each company HQ at Signal Training Centre,BSF Chakur, Maharashtra	Deptt.	0	0	1	28.19		0		0			0	0.23
565	BSF	Madhya Pradesh	Construction of entrance gate at BSF Academy, Tekanpur, Madhya Pradesh	Deptt.	0	2	3	59.94	12	1.31	2	3.22			0	0.65
										0		0			0	0
566	BSF	Madhya Pradesh	Construction of providing & erection of steel structure and roof over open air auditorium at Academy	Deptt.	0	1	3	59.89	1	3.25	2	9.09			0	0.65
										0		0			0	0
567	BSF	Madhya Pradesh	Construction of security Fencing 5.35 Kms from Bona Gate towards widow quarters at Tekanpur Academy, Madhya Pradesh	Deptt.	0	17	4	59.93	3	1		0			0	0.36
										0		0			0	0
568	BSF	Madhya Pradesh	Construction of security cum boundary wall in front of Academy House and officers colony towards NH-75	Deptt.	0	30	7	59.83	7	2.71		0			0	0.62
										0		0			0	0
569	BSF	Madhya Pradesh	Improvement of 39 nos. Type-II quarters at Takenpur Signal unit (TSU) BSF Academy, Madhya Pradesh	Deptt.	0	2	16	59.99	3	0.48	2	1			0	0.29
										0		0			0	0
570	BSF	Tamil Nadu	Construction of guard room at BSF campus	Deptt.	0	0	5	15.39		0		0			0	0
571	CISF	Delhi	Construction of reception cum registration counter at the from gallery nursing staion X- ray room at Saket, New Delhi	CPWD	3	1	6	3.41		0		0			0	0
572	CISF	Delhi	Construction of 2 nos. portable huts for mess (dining hall) Mahipalpur New Delhi	CPWD	1	7	0	42	16	2.06	2	4.01	12	41 to 214	8.8	0
573	CiSF	Delhi	Renovation of hospital building & physiotherapy room by providing platform with kota stone flooring adjoining to the canteen area at CISF campus Saket	CPWD	5	8	13	24.59	35	9.86	1	0.32	61	(-) 50 to 1624	6.64	0
574	CISF	Delhi	Electrification of 13 nos. portable huts at Mahipal pur, New Delhi	CPWD	NA	NA	5	10.07	13	1.6	1	3.15	7	(-60) to 154	3.09	0

575	CISF	Delhi	Construction of portable huts for kitchen and ration store for mess at Mahipal pur	CPWD	1	7	3	21.07		0	0			0	0	
576	CISF	Chhattisgarh	Construction of 2 nos. drill sheds for Regional Training Centre, CISF Bhilai	CPWD	7	3	5	55.11	5	0.75	3	6.08	8	(-) 100 to 498	12	0.57
577	CISF	Chhattisgarh	Construction of various works for armoury & magazine building at base workshop at Regional Training Centre, CISF at Bhilai	CPWD	9	4	9	58.01		0	0	0	5	45 to 183	15.2	0.3
578	CISF	Chhattisgarh	Construction of perimeter wall from SOs ATM gate to corner at CISF Regional Training Centre, Bhilai	CPWD	2	3	2	46.22	1	0.11		0	6	(-) 74 to 1176	2.53	0.1
579	CISF	Chhattisgarh	Construction of Training Block for CISF Regional Training Centre Bhilai	CPWD	0	0	9	310	19	1.21	2	0.35	111	(-)100 to 600	6.61	0.5
580	CISF	Chhattisgarh	Construction of building at CISF Regional Training Centre, Bhilai	CPWD	12	6	5	20.32	11	0.65		0	18	(-)100 to 546	1.56	0
581	CISF	Madhya Pradesh	Re-carpeting of roads in non-residential area, Barwaha, Madhya Pradesh	CPWD	11	1	7	27.42		0		0			0	0
582	CISF	Madhya Pradesh	Re-carpeting of roads in residential area, Barwaha, Madhya Pradesh	CPWD	3	1	7	27.02		0		0			0	0
583	CISF	Madhya Pradesh	Providing and fixing chain link & concertina coil fencing along choral river bank of old campus, Barwaha	CPWD	0	1	3	28.7	1	2.74		0			0	0
584	CISF	Madhya Pradesh	Construction of collapsed compound wall near WT Ground for CISF Regional Training Centre, Barwaha	CPWD	2	1	2	21.25	2	1.16		0			0	0
585	CISF	Madhya Pradesh	Repair & maintenance of non-residential buildings of CISF, Barwaha	CPWD	12	1	5	15.69		0		0			0	0
586	CISF	Rajasthan	Construction of laying chain link fencing around quarter Guard Deoli, Rajasthan	CPWD	3	1	4	28.9	3	0.47		0	3	(-) 100 to 168	1.6	0
587	CISF	Rajasthan	Construction of rain water harvesting system at CISF campus Regional Training Centre-I, Deoli, Rajasthan	CPWD	4	3	4	23.02	1	0.19		0	2	(-) 100 to 50	3.78	0
588	CISF	Rajasthan	Construction of residual work at ceremonial parade ground Deoli, Rajasthan	CPWD	3	2	3	42.05	8	2.34		0	2	(-) 100 to 115	4.87	0
589	CISF	Rajasthan	Construction of boundary wall around cemetery ground Deoli, Rajasthan	CPWD	1	1	21	18.67	4	0.53		0	5	(-)90 to 196	1.76	0
590	CISF	Rajasthan	Providing street light from C Comany to neckchal temple, CPWD office to Ajmeri gate and Ajmeri gate to war memorial Deoli, Rajasthan	CPWD	7	2	5	38.26		0	0	0	4	-73to 107	2.02	0
591	CISF	Tamil Nadu	Re-surfacing of internal roads in RB area of CISF campus, Tamil Nadu	CPWD	0	1	0	57.38		0		0			0	0
592	CISF	Telangana	Repairing & raising the height of boundary wall, fixing of concertina coil etc. from Gate No.2 to M.T. Section of CISF, Hakimpet, Hyderabad.	CPWD	3	2	3	46.24		0		0			0	0

593	CISF	Telangana	Extension of viewers gallery (on either side) at Ceremonial Parade Ground of CISF at Hakimpet, Hyderabad.	CPWD	0	1	1	37.17	12	6.13	1	0.88			0	0
594	CISF	Telangana	Repairs & Maintenance of Non residential buildings of CISF at Hakimpet, Hyderabad.	CPWD	0	0	1	29.83	14	4.17		0			0	0
595	CISF	Telangana	Construction of 200 bedded semi permanent barracks for trainees at NISA	CPWD	NA	NA	NA	29.63		0	1	3.19			0	0
596	CISF	Uttar Pradesh	Construction of boundary wall with coil fencing at kalindipuram, Allahabad	CPWD	0	2	1	45		0	0	0	8	164	11	0
597	CISF	Uttar Pradesh	Construction of main gate at Kalindipuram Allahabad, Uttar Pradesh	CPWD	0	2	18	15	1	0.01		0	22	317	0.07	0
598	CISF	Tamil Nadu	Construction of 4 nos. bore well at CISF campus, Tamil Nadu	C PWD	1	2	2	18.92		0		0			0	0
599	CISF	Tamil Nadu	Providing false ceiling, vitrified tiles and misc. work at GOs mess at CISF campus, Tamil Nadu	CPWD	0	0	0	14.08		0		0			0	0
600	CRPF	Delhi	Strengthening of existing boundry wall, Mahavir Nagar, New Delhi	CPWD	0	5	4	46.08	38	10.48		0	17	(-)45 to 1038	7.01	0
601	CRPF	Delhi	Construction of water proofing treatment, at Group Centre, CRPF Jharoda Kalan New Delhi	CPWD	1	5	16	28.05	13	4.52		0	3	(-) 100 to 1414	9	0
602	CRPF	Delhi	Construction of approach road to parade ground	CPWD	0	1	0	59.76	7	31.5	1	0.02	11	(-) 100 to 116	6.25	0
603	CRPF	Delhi	Construction of 10 squad post	CPWD	1	5	2	53.33	8	10.56		0	8	44 to 110	4.48	0
604	CRPF	Delhi	Providing security light along with periferal wall	CPWD	23	3	7	44.52	10	88.6		0	13	(-)90 to 825	63.1	0
605	CRPF	Assam	Construction of development repair by re-carpeting of road/by lanes of Group Centre, CRPF, Guwahati, Assam	CPWD	2	9	2	35.26	2	1.83	1	0.09	4	(-)100 to 30	0.56	0.21
606	CRPF	Chhattisgarh	Construction of BIN Type magazine Group Centre CRPF at Bilaspur	CPWD	0	2	8	29.79		0	0	0	15	- 100 to 351	2.25	0
607	CRPF	Gujarat	Construction of strengthening of existing compound wall and construction of new compound wall in place of damaged part of the compound wall around the campus of Group Centre, CRPF at Gandhi Nagar.	CPWD	3	9	8	58.21		0		0			0	0
608	CRPF	Gujarat	Construction of re-carpeting of internal roads at Group Centre, CRPF, Gandhinagar.	CPWD	0	3	1	44.98	1	0.31		0			0	0
609	CRPF	Gujarat	Construction of 3 m wide kachcha peropherial road for patrolling along the compound wall at Group Centre, CRPF Campus, Gandhi Nagar.	CPWD	2	22	5	53.08	4	6.2	1	8.44	1	216	0.09	0
610	CRPF	Gujarat	Construction of BIN Type magazine building for 100 Bn., Rapid Action Force, Vastral, Ahmedabad	CPWD	30	11	4	30.32	2	0.21	1	3.4	2	31 to 75	0.1	0

611	CRPF	Gujarat	Construction of Grain godown cum shopping centre for 100 Bn., Rapid Action Force, Vastral, Ahmedabad	CPWD	4	30	6	36.48		0	0			0	0	
612	CRPF	Haryana	Repair & re-carpeting of worn out portions of main road at Group Centre CRPF, Pinjore, Haryana	CPWD	18	0	0	33.8		0	0			0	0	
613	CRPF	Jammu & Kashmir	Providing of aluminium partition for making office cabins for special DG Jammu	CPWD	0	1	1	8		0	0			0	0	
614	CRPF	Jammu & Kashmir	Construction of open surface drain along the boundary wall for CRPF campus Nagrotad	CPWD	0	0	1	22		0	0			0	0	
615	CRPF	Jammu & Kashmir	Construction of Dhobi ghat at Group Centre CRPF Lethpora	CPWD	0	0	4	57		0	0			0	0	
616	CRPF	Jammu & Kashmir	Annual repair and maintenance of CRPF campus Bantalab	CPWD	NA	NA	0	11		0	0			0	0	
617	CRPF	Jharkhand	Construction of electrical sub station for 209 , COBRA Bn., Kunti, Jharkhand	CPWD	0	0	2	90.68		0	0			0	0	
										0	0			0	0	
618	CRPF	Jharkhand	Construction of BIN Type magazine for Group Centre, CRPF, Sambo, Ranchi	CPWD	7	12	3	33.53		0	0			0	0	
										0	0			0	0	
619	CRPF	Jharkhand	Construction of BIN type magazine for 203 COBRA Bn., Barhi, Hazaribagh	CPWD	3	10	4	27.61		0	0			0	0	
620	CRPF	Jharkhand	Construction of electrical substation for 203, COBRA Bn., Barhi, Hazaribagh	CPWD	2	9	5	36.58		0	0			0	0	
621	CRPF	Karnataka	Construction of 135 men barrack at Taralu, Bengaluru (Temporary structure)	CPWD	3	5	0	59.26		0	0			0	0	
622	CRPF	Kerala	Electrical renovation of (i) 192 Type-II quarters (ii) 138 Type-I special quarters of CRPF at Pallipuram, Trivandrum	CPWD	0	19	17	57.87	2	4.48	1	1.08			0	0
623	CRPF	Kerala	Construction room for interactive arms training at CRPF Peringome, Kannur	CPWD	9	8	7	0	9	0.41		0			0	0
624	CRPF	Kerala	Construction for providing peripheral lights, street lights, power supply to the new open well & 4 nos. watch towers-Regional Training Centre, Peringome	CPWD	0	11	5	0	18	5.84		0			0	0
625	CRPF	Maharashtra	Repair and carpeting to the internal road including dressing shoulder and providing masonry storm water drainage wherever required at 102 Bn., CRPF Rapid Action Force, Talaja, Navi-Mumbai	CPWD	6	23	22	59.74		0	0			0	0	
626	CRPF	Maharashtra	Diversion of 150 and 200 mm CI pipe line at hilly area and near Jack well for Group Centre, CRPF, Talegaon, Pune	CPWD	2	0	3	48.03		0	0			0	0	
627	CRPF	Maharashtra	Construction of 7 nos. sentry morcha with guard room for CoBRA Bn. at Chitapur, Bhandara	CPWD	13	0	4	91.72		0	0			0	0	
628	CRPF	Rajasthan	Construction of maintenance and aesthetic improvement of Masuda House	CPWD	8	2	2	27.04	29	3.61		0	9	(-)100 to 286	6.69	0

629	CRPF	Rajasthan	Renovation of Type-II quarters. No. 01 to 48 at Group Centre-I, Ajmer.	CPWD	1	2	5	58.44	37	12.35	1	0.24	7	(-) 100 to 130	8.17	0
630	CRPF	Rajasthan	Development of two nos. children park in residential area at CRPF campus, Rajasthan	CPWD	1	29	3	54.36	4	1.3	0	0	13	(-)100 to 1185	4.35	0
631	CRPF	Rajasthan	Development of existing pond at CRPF campus, Rajasthan	CPWD	1	3	6	44.08	8	4.16	1	0.09	27	(-)100 to 312	7.67	0
632	CRPF	Rajasthan	Renovation of toilets of barrack No. 1 to 5 at CRPF campus, Rajasthan	CPWD	1	12	5	46.61	16	9.34	0	0	56	(-)100 to 656	13.6	0
633	CRPF	Tamil Nadu	Construction of guard room near GOs mess	CPWD	8	2	2	27.9	0	0	0	0	0	0	0	0
634	CRPF	Tamil Nadu	Construction of drilling 6 numbers bore well and providing of pump set with service connections	CPWD	0	3	0	23.92	0	0	0	0	0	0	0	0
635	CRPF	Tamil Nadu	Construction of approach road to all 4 numbers newly constructed drill shed at Regional Training Centre, Avadi	CPWD	1	1	0	24.11	0	0	0	0	0	0	0	0
636	CRPF	Telangana	Renovation of 16 nos. new Type-IV residential quarters CRPF, Hyderabad	CPWD	0	11	12	29.75	28	5.12	12	4.3	0	0	0	0
637	CRPF	Telangana	Upgradation of main office building including DIGP range office building. at Group Centre, CRPF, Hyderabad,	CPWD	4	11	12	42.69	51	3.72	4	3.6	0	0	0	0
638	CRPF	Telangana	Repair/replacement of main sewer line in non-residential area and some place at residential area of CRPF	CPWD	3	7	2	44.33	5	1.79	9	3.18	0	0	0	0
639	CRPF	Telangana	Providing exhaust fans in kitchen of 972 nos. family quarters at CRPF campus in Telangana	CPWD	NA	NA	1	44.82	9	1.5	0	0	0	0	0	0
640	CRPF	Telangana	Re-carpeting of bituminous road & providing of kerb stones along with road of parade ground at Group Centre, CRPF, Jawaharnagar	CPWD	0	15	1	33.96	6	0.83	0	0	0	0	0	0
641	CRPF	Uttar Pradesh	Construction of 121 nos. BOAC at CRPF campus, Allahabad	CPWD	39	1	4	29	2	0.03	1	0.01	0	0	0	0
642	CRPF	Uttar Pradesh	Renovation of 40 nos. toilets at CRPF campus in Allahabad	CPWD	0	2	3	46	0	0	0	0	0	0	0	0
643	CRPF	Uttar Pradesh	Renovation of street light, park light at CRPF campus in Allahabad	CPWD	0	2	10	30	6	0.02	2	0.02	7	3536	0.03	0
644	CRPF	West Bengal	Construction of perimeter/security wall for quarter Guard at Group Centre, CRPF, West Bengal	CPWD	0	0	12	28.23	2	0.07	1	0.13	0	0	0	0
645	CRPF	West Bengal	Construction of BIN Type magazine for Group Centre, CRPF, Siliguri	CPWD	26	7	9	29.79	4	0.22	1	1.31	11	34 to 272	18.8	0
646	CRPF	West Bengal	Construction Dhobi Ghat at Group Centre, CRPF, Siliguri	CPWD	4	4	5	16	0	0	0	0	37	- 100 to 766	5.46	0
647	CRPF	West Bengal	Construction of cycle and motor cycle shed near administration block at Group Centre, CRPF, Siliguri	CPWD	2	2	1	19.69	16	4.97	0	0	0	0	0	0
648	CRPF	Madhya Pradesh	Construction of permanent morcha near all main gate/office/important place for Group Centre, CRPF Neemuch, Madhya Pradesh	CPWD	0	4	2	44.98	42	4.98	0	0	0	0	0	0



649	CRPF	Madhya Pradesh	Construction of 03 nos. open wells for Regional Training Centre, Neemuch	CPWD	0	2	1	44.97	6	0.81		0				0	0
650	CRPF	Madhya Pradesh	Replacement of false ceiling of main office and signal centre of 4 signal Bn. CRPF in Madhya Pradesh	CPWD	0	2	4	44.61	24	2.08		0				0	0
651	CRPF	Madhya Pradesh	Renovation of Kanetkar Barrack No. 1 & 2 Central Training Centre, CRPF, Neemuch	CPWD	2	3	5	44.76	17	2.31	4	0.91	46	36	15		0
652	CRPF	Madhya Pradesh	Construction of 5 nos. kote room at Group Centre, CRPF, Naya Gaon, Gwlior	CPWD	0	3	27	45.31	11	8.27	3	1.13	35	33	13.6		0
653	CRPF	Tamil Nadu	Construction of compound wall with gate around 12 Mahila SOs dormitory and 60 women barracks of CRPF in Tamil Nadu	CPWD	3	3	1	11.49		0		0				0	0
654	CRPF	Tamil Nadu	Construction of compound wall for Type- VI family quarters at CRPF campus, Tamil Nadu	CPWD	3	3	1	20.43		0		0				0	0
655	ITBP	Delhi	Construction of sitting gallery for force personnel at ITBP campus in Delhi	Deptt.	0	0	1	36.14		0		0				0	0.26
656	ITBP	Delhi	Construction of sitting gallery for VIP personnel at ITBP campus in Delhi	Deptt.	0	0	1	36.17		0		0				0	0.26
657	ITBP	Delhi	Construction of boundary wall at ITBP campus	Deptt.	0	0	5	38.66		0		0				0	0.39
658	ITBP	Delhi	Construction of family quarters at ITBP campus in Greater Noida	Deptt.	0	0	6	59.97	7	0.3		0				0	0.6
659	ITBP	Delhi	Construction of toilet & bath room at ITBP campus	Deptt.	0	0	3	12.61		0		0				0	0.12
660	ITBP	Arunachal Pradesh	Construction of 04 nos. corrugated galvanised iron or steel (CGI) sheet shed in patrol route of Lungar sub sector.	Deptt.			3	36.4		0		0				0	0
661	ITBP	Arunachal Pradesh	Construction of 04 nos. dining hall for ATC Lohitpur.	Deptt.			6	24.48		0		0				0	0
662	ITBP	Arunachal Pradesh	Constructions of SOs living accommodation at ITBP campus Arunachal Pradesh	Deptt.			0	13.66		0		0				0	0
663	ITBP	Assam	Providing erection of 04 nos. plastic huts or store and jawans accommodation at Tezpur	Deptt.	#VA!	#VAL UE	5	28.02	2	0.15	1	0.64	2	100 to 145	0.11		0
664	ITBP	Haryana	Renovation of 64 nos.T-III, quarters. at Ramgarh	Deptt.	3	3	3	39		0		0				0	0.3
665	ITBP	Haryana	Renovation of 02 No. old 120 Men Jawan Barrack at Ramgarh	Deptt.	1	0	3	33		0		0				0	0.32
666	ITBP	Jammu & Kashmir	Renovation of ceiling of Type-I/24 and Type-II/36 nos. quarters Leh	Deptt.	0	1	4	27		0		0				0	0.27
667	ITBP	Jammu & Kashmir	Upgradation of children park near family quarters at 15th Bn. ITBP Leh	Deptt.	0	1	8	18		0		0				0	0.17

668	ITBP	Jharkhand	Providing 4 nos. Pre-fabricated Huts of size 19.52 mx6.1 m including 1.525 m veranda & attached 5 nos. water closet (W/C) and 4 nos. bath for each Hut for ITBP, Ranchi SH: Preparation of base and flooring for Pre-fabricated Huts	CPWD	1	1	8	52.32							0	0	0	0
669	ITBP	Jharkhand	Providing 4 nos. Pre-fabricated Huts of size 19.52 mx6.1 m including 1.525 m veranda & attached 5 nos. water closet (W/C) and 4 nos. bath for each Hut for ITBP, Ranchi SH: Supply and erection of prefabricated huts.	CPWD	1	1	12	27.12							0	0	0	0
670	ITBP	Jharkhand	Construction of non residential building for 40th Bn. ITBP, Ranchi SH: Development of site & bulk service (Civil&Electrical) SH: Providing installation, testing and commissioning of 2 nos. pressure filter cum iron removal filtration plant capacity 50 cum per hour	CPWD	0	1	13	26.92							0	0	0	0
671	ITBP	Jharkhand	Construction of non residential building for 40th Bn. ITBP, Ranchi SH: Development of site & bulk service (Civil&Electrical) SH: Construction of 100000 litre capacity RCC elevated service reservoir for water and underground Sump	CPWD	0	1	11	58.42							0	0	0	0
672	ITBP	Jharkhand	Construction of non residential building for 40th Bn. ITBP, Ranchi SH: Development of site & bulk service (Civil&Electrical) SH: providing, installing, testing & commissioning of fluoride filtration treatment plant capacity 50 Cum per hour.	CPWD	0	1	13	31.14							0	0	0	0
673	ITBP	Karnataka	Construction of semi permanent SOs mess, at 44th Battalion, ITBP, Belgaum	Deptt.	NA	4	0	39.45	8	1.84	0	25	30	0.4				0
674	ITBP	Karnataka	Construction of 02 numbers semi permanent kitchen and dining hall for jawans at 44th Battalion, ITBP, Belgaum	Deptt.	NA	4	0	30.67	10	3.01	0							0
675	ITBP	Madhya Pradesh	Augmentation of water supply system at ITBP Regional Training Centre campus at Karera through rain water harvesting	Deptt.	0	3	3	59.5	7	9.13	0							0
676	ITBP	Madhya Pradesh	Construction of 01 (one) double storey building for administration staff at Regional Training Centre, ITBP, Karera	Deptt.	1	1	3	55.53			0	0						0
677	ITBP	Punjab	Construction of sewage treatment plant of 0.2 MLD for ITBP in Punjab	CPWD	4	0	7	40			0	0						0
678	ITBP	Sikkim	Construction of jawan line including toilet at Kerang Post of 11th Bn. ITBP in Sikkim	Deptt.	0	13	17	25.22			0	0						0
679	ITBP	Tamil Nadu	Construction of semi-permanent store building at 45 Bn. ITBP in Tamil Nadu	Deptt.	1	1	10	19.02			0	0						0
680	ITBP	Tamil Nadu	Construction of semi permanent Type GOs mess with provision of drawing room, dining hall, kitchen pantry and store at ITBP campus in Tamil Nadu	Deptt.	1	3	7	42.81			0	0						0

681	ITBP	Uttra Khand	Construction of providing parameter fencing around the camp at upper Rimkhim and lower Limkhim Lathal and Sanchutalla Post in Uttra Khand	Deptt.	0	7	3	54							0	0			0	0.52	
682	ITBP	Uttra Khand	Providing chain link fencing at Malari post, ITBP in Uttra Khand	Deptt.	0	4	3	51							0	0			0	0.55	
683	ITBP	Uttra Khand	Construction of jawan barrack at Jagrao post at 8th Bn. Gaucher, Uttra Khand	Deptt.	0	2	19	30							0	2	0.04	13	534	0.02	0.29
684	ITBP	Uttra Khand	Construction of GOs accommodation at Gastoli post at 8th Bn. Gaucher, Uttra Khand	Deptt.	0	1	6	25							0	0				0	0.21
685	ITBP	Uttra Khand	Providing water proofing treatment applying weather code on outer walls and construction at 23rd Bn. Dehradun, Uttra Khand	Deptt.	6	3	3	40							0	0	0	1	35	0.04	0.42
686	NSG	Delhi	Construction of toilet dwelling unit in Manesar	Deptt.	1	1	12	59.98	25	4.77					0					0	0
687	NSG	Delhi	Construction of water tank, Manesar	Deptt.	1	1	3	39.98	29	4.05					0					0	0
688	NSG	Delhi	Construction of lawn tennis court, Manesar	Deptt.	4	4	17	35.85		0					0					0	0
689	NSG	Delhi	Construction of cook house at Manesar	Deptt.	0	1	6	14.98	15	3.69					0					0	0
690	NSG	Delhi	Construction of Operation Room at Mahram Nagar, New Delhi	Deptt.	14	4	9	34.43		0					0					0	0
691	SSB	Delhi	Renovation of level-II Communication Center, R.K. Puram New Delhi	Deptt.	5	2	4	31.12		0	0	0	22	-100 to 1717					2.65		1.31
692	SSB	Delhi	Construction of M.T.Guard Ghitorni, New Delhi	Deptt.	0	11	6	15.63	4	3.34					0			37	(-100 to 2346)	6.91	0.16
693	SSB	Delhi	Renovation of computer branch at R.K. Puram New Delhi	Deptt.	0	0	2	3.67		0	0	0	24	-100 to 216					10.44		0.42
694	SSB	Delhi	Construction of S.P.Canteen Ghitorni, New Delhi	Deptt.	0	13	4	26.3	2	0.93	1	4	63	(-100 to 2650)					20.8		0.26
695	SSB	Delhi	Renovation of quarter. Guard Ghitorni, New Delhi	Deptt.	0	6	9	59.51		0		0			0					0	0.6
696	SSB	Arunachal Pradesh	Construction of 02 nos. 20 men barrack at Comany HQ Jang under 38th Bn.SSB, Arunachal Pradesh	Deptt.	0	12	7	44.62	12	2.49	6	1.3								0	0
697	SSB	Arunachal Pradesh	Repair and re-carpeting of internal bituminous road and water bound Macadam at 34th Bn. Dirang, Arunachal Pradesh	Deptt.	#VALUE!	#VALUE	9	14.13	1	0.1		0								0	0
698	SSB	Arunachal Pradesh	Construction of garage for medium and heavy vehicles at 38th Bn. Tawang, Arunachal Pradesh	Deptt.	0	10	14	22.75	2	1.19		0								0	0
699	SSB	Assam	Construction of 02 nos. barrack for jawans at border out post Kalajhar under 23rd Bn. (Sub Head: Barrack for transit personnel)	Deptt.	0	7	4	28.53		0		0								0	9.82

700	SSB	Assam	Construction of 01 no. residence for Commandant and one officer at 33rd Bn. Rangia, Assam	Deppt.	0	4	4	16.3	5	0.46	6	1.26			0	7.59
701	SSB	Himachal Pradesh	Construction of class room at Sapri, Himachal Pradesh	Deppt.	0	0	0	48		0		0			0	0
702	SSB	Himachal Pradesh	Relaying of existing sewer line at telecom Training. Centre. SSB Down Kothi, Kasumpti, Shimla (Himachal Pradesh)	CPWD	0	0	0	34		0		0			0	0
703	SSB	Himachal Pradesh	Renovation of existing bituminous internal road at SSB Kasumpti, Shimla.	CPWD	0	0	0	16		0		0			0	0
704	SSB	Himachal Pradesh	Construction of overhead reinforced cement concrete tank of 50000 liter capacity at SSB Kasumpti, Shimla.	CPWD	7	4	35	14		0		0			0	0
705	SSB	Uttra Khand	Construction of Barbed wire fencing at Bn. HQrs Champawat, Uttra Khand	Deppt.	0	3	3	40	12	0.09		0			0	0.44
706	SSB	Uttra Khand	Construction of trade single men shop and ware house at Frontier HQ Ranikhet	Deppt.	0	20	2	19	30	0.03		0			0	0.2
707	SSB	Uttar Pradesh	Providing prefabs structures at Lakimpur Kheri, Uttar Pradesh	Deppt.	0	8	3	60		0	0	0	7	570	0.03	0.63
708	SSB	Uttar Pradesh	Construction of permanent building at border out post bankati under 39th Bn. Palia, Uttar Pradesh	Deppt.	0	0	15	58	23	0.03		0	53	540	0.03	0.56
709	SSB	Uttar Pradesh	Construction of initial infrastructue at 26th Bn. HQ SSB Pilibhit (i) Construction of Jawan barrack 02 nos. (ii) Construction of toilet block-10 No.	Deppt.	0	3	0	60		0		0			0	0
710	BSF	Maharashtra	Construction of 11 nos. semi permanent structure at Signal Training Centre BSF Chakur, Maharashtra	Deppt.	0	0	4	35.86	2	1.58	2	1.73			0	0.34
										3016		1080			8288	217

**Annex-1.4**  
**Non-production of records by CAPFs/Executing agencies**  
**(Refer para 1.10)**

(₹ in lakh)

S.No.	Name of Agency	Name of force	Name of the work	Records not provided
1.	CPWD	CRPF	Bulk and development services for CRPF group centre at Kadarapur;	Client Request for submission of PE
2.	CPWD	CRPF	Construction of administration and training block for Group Center and Academy at Kadarapur	Client Request for submission of PE
3.	CPWD	CRPF	Construction of approach road to connect CRPF campus from main village road to Kadarapur	Client Request for submission of PE
4.	CPWD	CRPF	Construction of approach road to parade ground, leveling of surrounding area, external drainage work and water supply lines to green areas at CPRF Group center, Kadarapur	Client Request for submission of PE
5.	CPWD	CRPF	Augmentation of 3 electric sub-stations and replacement of high tension under ground cable at CPRF Camp, Jharoda Kalan.	Client Request for submission of PE
6.	CPWD	CRPF	Providing security light along periphery wall for strengthening of security arrangement at Group Centre, CRPF Campus, Jharoda Kalan	Client Request for submission of PE
7.	CPWD	CRPF	Construction of 699 family quarters for CRPF Group Centre at Kadarapur	Client Request for submission of PE
8.	CPWD	NSG	Construction of boundary wall at NSG HQ, Mehram Nagar, New Delhi	Client Request for submission of PE
9.	CPWD	NSG	Construction of 8 additional classrooms for Montessori school at NSG Camp, Manesar	Client Request for submission of PE
10.	CPWD	NSG	Construction of semi-permanent structure on 5 acres of land allotted to NSG near Indira Gandhi International Airport	Client Request for submission of PE
11.	CPWD	NSG	Construction of indoor shooting range at NSG, Manesar	Client Request for submission of PE
12.	CPWD	NSG	Development of 5 acres land near IGI Airport	Client Request for submission of PE
13.	CPWD	CISF	Electrification of 13 huts at CISF, GBS, Mahipalpur, New Delhi	Client Request for submission of PE
14.	CPWD	CISF	Reception cum registration counter at the front gallery, nursing station in hospital ward and racks in lab and x – ray room at CISF campus, Saket	Client Request for submission of PE

15.	CPWD	CISF	Renovation/repair of hospital building and physiotherapy room at CISF Campus, Saket	Client Request for submission of PE
16.	CPWD	BSF	Providing 2 320 KVA silent Type DG sets at BSF (HQ) Block No. 10, CGO complex	Client Request for submission of PE
17.	CPWD	CRPF	Construction of approach road to connect CRPF campus from main village road to Kadarapur	PE not on records
18.	CPWD	CRPF	Construction of approach road to parade ground, leveling of surrounding area, external drainage work and water supply lines to green areas at CPRF Group center, Kadarapur	PE not on records
19.	CPWD	NSG	Construction of semi-permanent structure on 5 acres of land allotted to NSG near Indira Gandhi International Airport	PE not on records
20.	CPWD	NSG	Upgradation and modernization of electric system at NSG, Manesar	PE not on records
21.	CPWD	CISF	Electrification of 13 huts at CISF, GBS Unit at Mahipalpur	PE not on records
22.	CPWD	CISF	Reception cum registration counter at the front gallery nursing station in hospital ward and racks in laboratory and X-ray room while renovation of hospital building at CISF Campus, Saket	PE not on records
23.	CPWD	CISF	Renovation/repair of hospital building and physiotherapy room at CISF Campus	PE not on records
24.	CPWD	CRPF	Construction of approach road to parade ground, leveling of surrounding area, external drainage work and water supply lines to green areas at CPRF Group center, Kadarapur	AA&ES not found on records
25.	CPWD	CISF	Electrification of 13 huts at CISF, Government Security Building Unit at Mahipalpur, New Delhi	AA&ES not found on records
26.	CPWD	CRPF	Construction of approach road to parade ground, leveling of surrounding area, external drainage work and water supply lines to green areas at CPRF Group center, Kadarapur	TS not found on records
27.	CPWD	CRPF	Augmentation of 3 electric sub-stations and replacement of HT UG cable at CPRF Camp, Jharoda Kalan	TS not found on records

28.	CPWD	CISF	Electrification of 13 huts at CISF, GBS Unit at Mahipalpur	TS not found on records
29.	CPWD	CISF	Reception cum registration counter at the front gallery nursing station in hospital ward and racks in laboratory and X-ray room while renovation of hospital building at CISF Campus, Saket	TS not found on records
30.	CPWD	CRPF	Augmentation of 3 electric sub-stations and replacement of HT UG cable at CPRF Camp, Jharoda Kalan	NIT not found on records
31.	CPWD	CRPF	Construction of approach road to connect CRPF campus from main village road to Kadarapur	Justification not found on records
32.	CPWD	BSF	Providing 2 nos. 320 KVA Silent Type DG sets at BSF (HQ) Block No. 10, CGO complex, New Delhi	Installation not available on records
33.	CPWD	CRPF	Construction of approach road to parade ground, leveling of surrounding area, external drainage work and water supply lines to green areas at CPRF Group Center, Kadarapur	Completion Certificate not found on records
34.	CPWD	CRPF	Renovation of toilets and kitchen in Type II and Type IV quarters at CRPF camp, Jharoda Kalan	Completion Certificate not found on records
35.	CPWD	CRPF	Construction of 10 squad posts at Group Centre, Kadarapur	Completion Certificate not found on records
36.	CPWD	CRPF	Water proofing treatment to roofs for strengthening and to prevent seepage in Type II, III & IV quarters at CRPF, Jharoda Kalan	Completion Certificate not found on records
37.	CPWD	NSG	Construction of 8 additional classrooms for Montessori school at NSG Camp, Manesar	Completion Certificate not found on records
38.	CPWD	CISF	Construction of portable huts for kitchen and ration store for mess at CISF Campus	Completion Certificate not found on records
39.	CPWD	CISF	Construction of 2 portable huts for mess in CISF campus at GBS	Completion Certificate not found on records
40.	CPWD	CISf	Electrification of 13 huts at CISF, GBS Unit at Mahipalpur	Completion Certificate not found on records

41.	CPWD	CISF	Reception cum registration counter at the front gallery nursing station in hospital ward and racks in laboratory and X-ray room while renovation of hospital building at CISF Campus, Saket	Completion Certificate not found on records
42.	CPWD	CRPF	Construction of boundary wall along the periphery of campus, watch tower and drainage for 103 Bn., RAF, CRPF;	Labour Licence not obtained.
43.	CPWD	CRPF	Laying of GI pipeline from Najafgarh to CRPF Campus for supply of potable water and laying of CI pipeline for internal water supply grid;	Labour Licence not obtained.
44.	CPWD	CRPF	Bulk and development services for CRPF group centre at Kadarapur;	Labour Licence not obtained.
45.	CPWD	CRPF	Construction of administration and Training block for Group Center and Academy at Kadarapur;	Labour Licence not obtained.
46.	CPWD	CRPF	Construction of 10 squad posts at Group Centre, Kadarapur	Labour Licence not obtained.
47.	CPWD	NSG	Construction of composite structure for 52, SAG at Samalkha, New Delhi	Labour Licence not obtained.
48.	CPWD	NSG	Construction of 8 additional classrooms for Montessori school at NSG Camp, Manesar;	Labour Licence not obtained.
49.	CPWD	NSG	Construction of semi – permanent structure on 5 acres of land allotted to NSG near Indira Gandhi International Airport, New Delhi	Labour Licence not obtained.
50.	CPWD	NSG	Construction of indoor shooting range at NSG, Manesar;	Labour Licence not obtained.
51.	CPWD	CRPF	Laying of GI pipeline from Najafgarh, New Delhi to CRPF Campus for supply of potable water and laying of CI pipeline for internal water supply grid;	Fortnightly Labor Report not obtained..
52.	CPWD	CRPF	Renovation of toilets and kitchen in Type-II and Type-IV quarters at CRPF campus Jharoda Kalan, New Delhi	Fortnightly Labor Report not obtained.
53.	CPWD	NSG	Construction of indoor shooting range at NSG, Manesar;	Fortnightly Labor Report not obtained.
54.	CPWD	CISF	Electrification of 13 huts at CISF	Fortnightly Labor Report not obtained.
55.	CPWD	CISF	Renovation/repair of hospital building and physiotherapy room at CISF Campus	Fortnightly Labor Report not obtained.



56.	CPWD	BSF	Providing 2 320 KVA silent Type DG sets at BSF (HQ) Block No. 10, CGO complex	Fortnightly Labor Report not obtained.
57.	CPWD	CRPF	Laying of GI pipeline from Najafgarh to CRPF Campus for supply of potable water and laying of CI pipeline for internal water supply grid;	Records relating to deployment of technical personnel during the execution of work.
58.	CPWD	CRPF	Construction of approach road to connect CRPF campus from main viltakene road to Kadarapur;	Records relating to deployment of technical personnel during the execution of work.
59.	CPWD	CRPF	renovation of toilets and kitchen in Type II and Type IV quarters at CRPF camp, Jharoda Kalan; and	Records relating to deployment of technical personnel during the execution of work.
60.	CPWD	CRPF	Providing security light along periphery wall for strengthening of security arrangement at Group Centre, CRPF Campus, Jharoda Kalan; and	Records relating to deployment of technical personnel during the execution of work.
61.	CPWD	CRPF	Construction of 10 squad posts at Group Centre, Kadarapur	Records relating to deployment of technical personnel during the execution of work.
62.	CPWD	CRPF	Strengthening of existing boundary wall/fencing supplemented by iron grill and concertina coil at CRPF campus, Mahavir Nagar, New Delhi;	Records relating to deployment of technical personnel during the execution of work.
63.	CPWD	NSG	Construction of 8 additional classrooms for Montessori school at NSG Camp, Manesar;	Records relating to deployment of technical personnel during the execution of work.
64.	CPWD	CISF	Electrification of 13 huts at CISF	Records relating to deployment of technical personnel during the execution of work.
65.	CPWD	CISF	Renovation/repair of hospital building and physiotherapy room at CISF Campus	Records relating to deployment of technical personnel during the execution of work.

66.	CPWD	BSF	Providing 2 320 KVA silent Type DG sets at BSF (HQ) Block No. 10, CGO complex	Records relating to deployment of technical personnel during the execution of work.
67.	CPWD	CRPF	Construction of administration and Training block for Group Center and Academy at Kadarapur;	Monthly Progress Report not submitted
68.	CPWD	NSG	Construction of boundary wall at NSG Headquarters, Palam, New Delhi	Monthly Progress Report not submitted
69.	CPWD	NSG	Construction of semi – permanent structure on 5 acres of land allotted to NSG near Indira Gandhi International Airport;	Monthly Progress Report not submitted
70.	CPWD	NSG	Construction of 8 additional classrooms for Montessori school at NSG Camp, Manesar	Monthly Progress Report not submitted
71.	CPWD	BSF	Providing 2 320 KVA silent Type DG sets at BSF (HQ) Block No. 10, CGO complex	Insurance Cover not available
72.	CPWD	CISF	Construction of Training Block for CISF, Regional Training Centre, Bhilai. (2004-05)	P.E. and all the connecting records of constrworks. (Except M.B.)
73.	CPWD	CISF	Construction of Training Block for 3rd R.B., CISF, Bhilai.	Correspondence File, DE, Approved Copy of deviation statement, Extra items Statement, Substitutes items Statement, Mobilization Advance, EOT
74.	CPWD	CISF	Construction of Room for installation of Driving Training Simulator at CISF, Regional Training Centre, Bhilai.	Correspondence File, DE, Copy of Work order, Copy of agreement, Approved Copy of deviation statement, Extra items Statement, Substitutes items Statement, Final Exp/MB, Mob. Advance, EOT, Completion Certificate
75.	CPWD	CISF	Construction of Training Block for CISF, Regional Training Centre, Bhilai.	PE, Approved Copy of deviation statement, Extra items Statement, EOT
76.	CPWD	CRPF	Construction of 6 nos. Semi permanent building (22x8.5 MTrs) having AC sheet roofing, Group Centre, CRPF, Bilaspur.	Correspondence File, DE, Copy of Work order, Copy of agreement, Approved Copy of deviation statement, Extra items Statement, Substitutes items Statement, Final Exp/MB, Mob. Advance, EOT, Completion Certificate

77.	CPWD	CFPF	Construction of BIN Type magazine, Group Centre, CRPF, Bilaspur.	Correspondence File, DE, Copy of Work order copy of agreement, Approved Copy of deviation statement, Extra items Statement, Substitutes items Statement, Final Exp/MB, Mob. Advance, EOT, Completion Certificate
78.	NBCC	CRPF	Construction of 240 men Breacks at Gr.Noida.	Informactionas respects of penalty imposed and recoverd in contractor
79.	EPIL	AR	Construction of quarters Works in Dwarka, New Delhi	<ul style="list-style-type: none"> <li>i. Requisition letter</li> <li>ii. Preliminary estimates submitted by EPIL to AR in 2003, 2005 and 2008</li> <li>iii. MoU/agreement entered into by EPIL with AR in 2004</li> <li>iv. Sanction of ₹ 4.81 crore was communicated to EPIL by DGACR in January 2004 and revised estimated were submitted by EPIL in December 2005. The action taken by EPIL during 2004 and 2005 in respect of the above mentioned work</li> <li>v. Files and records related to tendering process carried out by EPIL in 2006 and 2008</li> <li>vi. Files and records related to submission of RA bill by M/s Meghalaya constrand the payment made by EPIL in this regard</li> <li>vii. Files and records related to correspondence with DGAR</li> </ul>

**Annex - 3.1**  
**Cases of increase in cost of land by State Government**  
**(Refer Para 3.1.1)**

(₹ in lakh)

Sl. No.	Force	Purpose of land acquired	Original cost of acquisition in first proposal	Final cost of land	difference in original and final cost	Number of times cost of land was revised	Percentage difference
1.	BSF	Establishment of Border Out Post (BOP) Konaban to minimize inter BOP distance and better domination of bordering area.	8.56	10.38	1.82	1	21.26
2.	BSF	Establishment of BOP-Raidighi under Sector HQ Raiganj (NB Ftr.)	10.19	17.20	7.01	1	68.79
3.	BSF	Establishment of BOP Bhaira Bn. Agar Das Para to minimize inter BOP distance and better domination of bordering area.	11.54	13.97	2.43	1	21.06
4.	BSF	Establishment of BOP Boxanagar to minimize inter BOP distance and better domination of bordering area.	15.37	32.52	17.15	2	111.58
5.	BSF	Establishment of Bn. HQ at Seiling, Aizawl-I (M&C Ftr.)	1,459.42	1,956.26	496.84	1	34.04
6.	SSB	For Group Centre HQs at Karnajora	134.40	144.72	10.32	1	7.68
7.	BSF	Establishment of BOP Yaku Bn. Agar to minimize inter BOP distance and better domination of bordering area.	8.95	40.10	31.15	1	348.04
8.	SSB	Establishment of Bn. HQ at Yangtey, Geyging	1,293.97	1,467.33	173.36	1	13.40
9.	BSF	To establish BOP (Nongjuri)	33.37	36.62	3.25	1	9.74
10.	BSF	Establishment of BSF Bn. HQ at Kumarghat	61.45	61.49	0.04	1	0.07
11.	BSF	To establish BOP (Sonatala)	24.39	24.89	0.50	1	2.05
12.	BSF	Establishment of BOP Chittabari to minimize inter BOP distance and better domination of bordering area.	11.43	13.86	2.43	1	21.26
13.	BSF	Establishment of BOP Acharjeepara to minimize inter BOP distance and better domination of bordering area.	3.44	4.16	0.72	1	20.93

14.	CRPF	For establishment of Battalion Camp Medinipur	184.31	188.00	3.69	1	2.00
15.	BSF	Acquisition of 80 acres land for establishment of Bn. HQ. at Varsagaon, Distt-Pune Maharashtra	5.28	5.31	0.03	0	0.57
16.	BSF	Acquisition of 70 Acres land for Bn. HQ at Baramsar (Ramgarh) Rajasthan	26.97	29.67	2.70	1	10.01
17.	SSB	Acquisition of land measuring 229.04 for establishment of two Reserve Bn. HQ, one Sector HQ and SSB Dog Training-cum-Breeding Centre in Distt- Alwar (Rajasthan)	752	827	75.00	1	9.97
18.	CRPF	Purchase of Rajputana Hotel Estate (RHE) building/land for ISA Mount Abu	500	1850	1,350.00	0	270.00
19.	ITBP	Acquisition of land for Bn. HQ, Madurai	77	80	3.28	1	4.26
20.	CISF	Acquisition of land for residential and non-residential building for 4th Reserve Bn.at Amaravathi, Pudur, Karaikuri, Sivagangai District	60	1003	943.03	1	1572.50
21.	SSB	Establishment of SSB Academy at Srinagar (Garhwal)	13.31	33.34	20.03	3	150.49
22.	SSB	Regarding sanction of additional amount for acquisition of land measuring 75 acre for 27th Bn. at Narkatiaganj	302	1237.94	935.94	3	309.91
23.	CRPF	Acquisition of land for establishment of Group Centre & Range HQ. at Trisundi Amethi	1669.32	3110.22	1,440.90	1	86.32
24.	ITBP	Acquisition of land for establishment of Bn. HQat Kanpur	1065.31	1091.34	26.03	1	2.44
25.	SSB	Acquisition of land for establishment of BOP - Nazulia	4.66	7.37	2.71	1	58.15
26.	SSB	Acquisition of additional land measuring 2.50 acres in respect of Company-cum-BOP HQ Sikta under 27th Bn. Narkatiaganj	18.18	34.77	16.59	1	91.25
27.	SSB	Acquisition of land for establishment of Sector HQ and Bn. HQ at Lakhimpur Khiri	923.27	1566.74	643.47	1	69.69
28.	CISF	Acquisition of land for establishment of CISF Group HQ Allahabad	1196.32	1450.1	253.78	1	21.21
29.	SSB	Revalidation sanction of one lac for acquisition of 2.50 acres additional land for establishment of Company HQ Sonba under 9th Bn. HQ	35.45	36.84	1.39	1	3.92
30.	SSB	Additional sanction for acquisition of additional land measuring 1.61 acres against 1.75 acres sanctioned initially for establishment of BOP HQ under Bn. HQ Sitamarhi-II	22.33	23.4	1.07	2	4.79

31.	SSB	Additional sanction for acquisition of land measuring 3 acres for establishment of BOP HQ Musachak under Bn. HQ Sitamarhi of Ftr. HQ Patna	53.18	58.03	4.85	1	9.12
32.	SSB	Additional sanction for acquisition of land measuring 03 acres for establishment of BOP HQ Basantapur under Bn. HQ Narkatiaganj	20.14	32.49	12.35	1	61.32
33.	SSB	Additional sanction for acquisition of 3.00 acre land for establishment of BOP HQ Yadavtola under Bn. HQ Thakurganj	8.1	14.12	6.02	1	74.32
34.	SSB	Acquisition of land for establishment of Bn. HQ. Dehardun	307.66	413.66	106.00	1	34.45
35.	SSB	Acquisition of land for establishment of Reserve Bn. HQ& Balance components of Ftr. HQ at Lucknow	117.43	5284.04	5,166.61	4	4399.74
36.	SSB	Sanction of additional amount for acquisition of lands in respect of 7 Company under 9 <sup>th</sup> Battalion Sitamarhi (Bihar).	71.23	156.03	84.80	2	119.05

**Annex - 3.2**  
**Irregularities in documentation of land acquisition**  
**(Refer Para 3.2.4)**

Sl. No.	Name of the State	Name of the Force	Purpose for which land was acquired	Remarks
1.	UK	SSB	Establishment of BOP HQ Khaldhunga-I	No lease/ sale deed executed
2.	UK	SSB	Establishment of BOP HQ Jhulaghat	No lease/sale deed executed
3.	UK	SSB	Establishment of Bn. HQ Dehardun	No lease/sale deed executed
4.	UK	SSB	Establishment of Company-Cum-BOP Basai	No lease/sale deed executed
5.	UK	SSB	Establishment of BOP Ghola	No lease/sale deed executed
6.	UK	SSB	Establishment of BOP Simbalghat	No lease/sale deed executed
7.	Bihar	SSB	Establishment of land in respect of BOP Khaniabad and BOP Mafiatola	Sale deed/ mutation not executed
8.	Bihar	SSB	Establishment of land in respect of Company Kanwa	Sale deed/ mutation not executed
9.	Bihar	SSB	Regarding sanction of additional amount for acquisition of land measuring 75 acre for 27th Bn. at Narkatiaganj	Sale deed/ mutation not executed
10.	Bihar	SSB	Acquisition of additional land measuring 2.50 acres in respect of Company-cum-BOP HQ Sikta under 27th Bn.Narkatiaganj	Sale deed/ mutation not executed
11.	Bihar	SSB	Revalidation sanction of 1 Lac for acquisition of 2.50 acres addl. Land for establishment of HQ Sonba under 9th Bn. HQ(Now 20th Bn. Sitamarhi)	Sale deed/ mutation not executed
12.	Bihar	SSB	Acquisition of land for BOP HQ Teenlalten under Bn. HQ Narkatiaganj (Bihar)	Sale deed/ mutation not executed
13.	Bihar	SSB	Additional sanction for acquisition of land measuring 3.96 acres for establishment of Company cum BOP HQ Lalbandi under Bn. HQ Sitamarhi	Sale deed/ mutation not executed
14.	Bihar	SSB	Additional sanction for acquisition of additional land measuring 1.61 acres against 1.75 acres sanctioned initially for establishment of BOP HQ Siiya under Bn. HQ Sitamarhi-II	Sale deed/ mutation not executed

15.	Bihar	SSB	Additional sanction for acquisition of land measuring 03 acres for establishment of BOP HQ Basantapur under Bn. HQ Narkatiaganj	Sale deed/ mutation not executed
16.	Bihar	SSB	Additional sanction for acquisition of 3.00 acre land for establishment of BOP HQ Yadavtola under Bn. HQ Thakurganj	Sale deed/ mutation not executed
17.	Bihar	SSB	Additional sanction for acquisition of land measuring 3 acres for establishment of BOP HQ Musachak under Bn. HQ Sitamarhi of Ftr. HQ Patna	Sale deed/ mutation not executed
18.	Rajasthan	SSB	Acquisition of land measuring 229.04 acres (110.85 acres in village Mauzur Tehsil Laxmangarh and 118.19 acres in village Dera Tehsil Rajgarh for establishment of two Reserve Bn. HQ One Sector HQ and SSB Dog Training-cum-Breeding Centre in Distt- Alwar (Rajasthan)	Sale deed/ mutation not executed



**Annex - 3.3**  
**Land not put to use**  
**(Refer Para 3.3)**

(₹ in lakh)

S. No.	Name of the State	Name of the Force	Purpose of land acquired	Date of land purchases	Amount paid	Reasons for not using the land
1.	Rajasthan	CISF	Acquisition of 35.60 hectare land for firing range of CISF MP Regional Training Centre Behror, Distt Alwar	21-12-2010	188.04	Permission not given by state Govt. for firing
2.	Gujarat	CRPF	Acquisition of 0.5 acre of land for Martyrs memorial at Rann of Kutch, Gujarat	03-11-2008	0.08	Preliminary estimate not received by CRPF from CPWD. Hence
3.	Gujarat	BSF	Acquisition of 77.19 Acres land for Marine Bn. HQ at Sedata Bhuj (Gujarat Ftr.)	26-06-2008	624.78	due to not transfer of land in the name of BSF
4.	UP	CISF	For establishing CISF Group HQ Allahabad	10.08.2010	1450.09	Unused
5.	UP	CRPF	Establishment of Camping site of Bn.Allahabad	08.06.2012	137.21	Unused
6.	UP	SSB	Establishment of BOP HQ Kapishwa under Bn. HQ. Sidharth Nagar	-	112.46	Unused
7.	UK	SSB	Establishment of Bn. HQ. Dehardun	17.08.2013	803.91	Sanction not received
8.	UK	SSB	Establishment of BOP Ghola	7.09.2011	2.58	Under use (Court case)
9.	Nagaland	AR	Acquisition of 75 acres land at Chakbama, Nagaland for IGAR	03-08-2011	264.15	Not shifting of IG office
10.	West Bengal	SSB	For Group Centre HQ. at Karnajora	16-02-1998	144.72	Transferred to BSF on 05.07.05
11.	Assam	AR	For establishment of an Assam Rifles battalion KLP.	16-12-2013	708.76	KLP under development
12.	Assam	CISF	Establishment of CISF 9th Reserve Bn. at Guwahati	06-09-2012	90.47	The area is vacant and presently the land is not under use as no infrastructure is available
13.	Arunachal Pradesh	SSB	For Establishment of 61st Bn. HQ. Tawang-II	14-06-2013	383.31	61st Battalion shifted to other place.
<b>Total</b>					<b>4910.56</b>	

**Annexure 3.4**  
**Land acquisition cases with deviation**  
**(Refer Para 3.1)**

(₹ in crore)

Sl. No.	Name of the Force	Purpose of land acquired	Proposed Area of land (in acre)	Area of land actually acquired/ allotted (in acre)	Authorization as per MHA norms (in acre)	Total land acquired (in acre)	Excess /shortfall in land acquired (in acre)
1.	AR	Acquisition of 150 acre of land at Modi, Manipur	150	150.00	80.00	150.000	70.00
2.	BSF	Establishment of Border Out Post (BOP) Dyke-VIII to minimize inter BOP distance and better domination of bordering area.	2.4	2.400	3.00	2.400	-0.60
3.	BSF	Establishment of BOP-Raidighi under Sector HQ. Raiganj (NB Ftr)	3.08	3.080	3.00	3.080	0.08
4.	BSF	Establishment of BOP Sabroom to minimize inter BOP distance and better domination of bordering area.	1.54	1.540	3.00	1.540	-1.46
5.	BSF	Establishment of BOP Bhaira Bn. Agar Das Para to minimize inter BOP distance and better domination of bordering area.	4	4.000	3.00	4.000	1.00
6.	ITBP	Acquisition of land for Bn. HQ. at Tezpur, Assam	74.12	74.120	77.19	74.120	-3.07
7.	SSB	For establishment of Company HQ. at Nalapara and Company BOP at Tankibasti under 37th Bn.SSB Mangaldoi	9.94	7.270	10.00	7.280	-2.72
8.	SSB	For Bn. HQ. at Malbazar	65.31	65.310	75.00	65.310	-9.69
9.	AR	Acquisition of 75 acres land at Chakbama, Nagaland for IGAR	75	75.000	33.00	75.000	42.00
10.	BSF	Establishment of Bn. HQ. at Seiling, Aizawl-I (M&C Ftr.)	88	88.000	77.19	88.000	10.81
11.	CRPF	For establishment of 207 COBRA Bn. at Salboni	141.24	141.240	50.00	141.240	91.24
12.	SSB	Establishment of BOP HQ. Lamyadhura and Phool Khola under 29th Bn. HQ. SSB Kahprail.	3.75	3.750	6.00	3.750	-2.25
13.	SSB	For establishment of Platoon Company HQ. at samarang under 37th Bn.SSB Mangaldoi	4.97	4.970	5.00	4.970	-0.03

14.	BSF	Establishment of BOP Yaku Bn. agar to minimize inter BOP distance and better domination of bordering area.	6	6.000	3.00	6.000	3.00
15.	CRPF	Acquisition of 25.5 acre of land for Bn. Site at Mokokchung, Nagaland	25.45	25.450	77.19	25.45	-51.74
16.	SSB	Establishment of Bn. HQ. at Yangtey, Geyging	64.00	64.000	75.00	64.00	-11.00
17.	AR	For establishment of an Assam Rifles batallion KLP	149	149.000	80.00	149.00	69.00
18.	BSF	To establish BOP (Nongjuri)	1.99	1.990	5.00	1.99	-3.01
19.	BSF	Establishment of BSF Bn. HQ. at Kumarghat	58.77	58.770	77.19	58.77	-18.42
20.	CISF	Establishment of CISF 9th Reserve Bn. at Guwahati	100	99.173	77.19	99.17	21.98
21.	ITBP	For Sector HQ. Tejpur, Assam	15	15.000	28.00	15.00	-13.00
22.	NSG	Regional Centre at Rajarhat, Kolkata on lease	34.315	34.315	1200	34.32	1165.9
23.	SSB	Establishment of SSB BOP 33rd Bn. on Indo Bangladesh Border (IBB)	2.48	2.480	3.00	2.48	-0.52
24.	AR	Acquisition of 13.051 acres land at Shangshak (on court) for Bn.	13.051	13.051	180.00	13.05	-166.95
25.	BSF	To establish BOP (Sonatala)	7.04	7.040	5.00	7.04	2.04
26.	SSB	For establishment of Platoon level BOP at Nonaikuti under 37 <sup>th</sup> Bn. SSB Mangaldoi	2.87	2.870	5.00	4.85	-0.15
27.	SSB	Establishment of BOP at Lingtam	2.47	2.470	3.00	2.47	-0.53
28.	SSB	Establishment of Company level BOP at Padamchen	2.47	2.470	5.00	2.47	-2.53
29.	SSB	For Establishment of 61st Bn. HQ. Twang-II	31.79	31.790	85.00	31.790	-53.21
30.	BSF	Establishment of BOP Chittabari to minimize inter BOP distance and better domination of bordering area.	4	4.000	5.00	4.00	-1.00
31.	BSF	Establishment of BOP Acharjeepara to minimize inter BOP distance and better domination of bordering area.	1.18	1.180	3.00	1.18	-1.82
32.	BSF	For establishment of Company level BOP of 162 Bn. BSF under Sector HQ. BSF Dhubri (Guwahati Ftr.)	6.48	6.480	5.00	6.48	1.48
33.	BSF	For establishment of Company level BOP of 162 Bn. BSF	2.604	2.604	5.00	3.25	-1.75
34.	BSF	For establishment of Platoon level BOP	2.83	2.830	3.00	2.83	-0.17
35.	CRPF	For establishment of Battalion Camp Medinipur	43.64	43.640	77.19	43.64	-33.55

36.	BSF	Acquisition of 80 Acres land for establishment of Bn. HQ. at Varsagaon, Distt- Pune Maharastra	80	80	77.19	80	2.81
37.	CRPF	Acquisition of 81.06 acre of land for 208 Cobra Bn. At Balaghat, Madhya Pradesh	81.06	81.06	77.19	81.06	3.87
38.	BSF	Acquisition of 70 Acres land for Bn. HQ. at Baramsar, Ramgarh, Rajasthan Ftr.	70	70	77.19	70	-7.19
39.	BSF	Acquisition of 6.5 Acres land for BOP- Deepawala, Rajasthan Ftr.	12.9375	6.5	5	6.5	1.50
40.	SSB	Acquisition of land measuring 229.04 acres for establishment of two Reserve Bn. HQ. one Sector HQ. and SSB Dog Training-cum-Breeding Centre in Distt- Alwar, Rajasthan	229.04	229.04	182.38	229.04	46.66
41.	BSF	Acquisition of 44 kenal & 17 marla land for BOP- Bobiya under Sector HQ. Indresh Nagar, Jammu Ftr.			5	5.61	0.61
42.	BSF	Acquisition of 46 kenal 14 Marla land for BOP 6R under Sector HQ. Indresh Nagar Jammu			5	5.84	0.84
43.	ITBP	Acquisition of 48.25 acre govt. land Bn. HQ. at samba, J&K	48.25	48.25	105	48.25	-56.75
44.	CISF	Residential & Non-residential building for 4th RB at Amaravathi, Pudur, Karaikuri, Sivagangai District	100	100	77.19	100	22.81
45.	BSF	Acquisition of land for Bn. HQ.			77.19	43.57	-33.62
46.	ITBP	Acquisition of land for Bn. & Sector HQ.			109.03	109.54	0.51
47.	BSF	Establishment of Bn. HQ. at Lucknow	65.343	65.343	77.19	65.343	-11.85
48.	CRPF	Establishment of Group Centre	106.86	91.7	165	91.7	-73.30
49.	SSB	Regarding sanction of additional amount for acquisition of land measuring 75 acre for 27th Bn. HQ. at Narkatiaganj	75	74.34	75	74.34	-0.66
50.	CRPF	Establishment of Group Centre & Range HQ. at Trisundi Amethi	264.73	264.73	165	264.73	99.73
51.	ITBP	Establishment of Battalion HQ. At Kanpur	75.063	69.504	77.19	75.06	-2.13
52.	SSB	Establishment of BOP - Nazulia	1.265	1.265	75	107.98	32.98
53.	BSF	Establishment of AI Rol Bn. Dehardun	20.09	20.09	77.19	20.09	-57.10

54.	CRPF	Establishment of camping site of Bn. at Allahabad	1.5	1.37	10	1.37	-8.63
55.	SSB	Establishment of Company-cum-BOP Basai	2.47	2.47	2.5	2.47	-0.03
56.	SSB	Establishment of BOP-Ghola	0.86	0.86	3	0.86	-2.14
57.	SSB	Establishment of BOP HQ. Khaldhunga-I	1.25	1.25	3	1.25	-1.75
58.	SSB	Additional sanction for acquisition of additional land measuring 1.61 acres against 1.75 acres sanctioned initially for establishment of BOP HQ. Siiya under Bn. HQ. Sitamarhi-II	3	2.86	3	2.86	-0.14
59.	SSB	Establishment of BOP at Simbalghat	2.347	2.347	3	2.35	-0.65
60.	SSB	Establishment of BOP HQ. Jhulaghat	1.5	1.5	3	1.5	-1.50
61.	SSB	Establishment of Bn. HQ. Dehardun	26.2	26.2	77.19	50.9	-26.29
62.	SSB	Establishment of Reserve Bn. HQ. & Balance components of Ftr. HQ. At Lucknow	107.98	43.29	75	83.5	8.50
63.	SSB	Acquisition of land in respect of (i) Company-cum-BOP Fatehpur, (ii) BOP Khaniabad (iii) Company-cum-BOP Pegtola (iv) BOP Mafiatola (v) BOP Bairia under 28th Battalion Araria	17	6	17	6	-11.00
64.	SSB	Sanction of additional amount for acquisition of lands in respect of (i) Company Kanwa (ii) Company Majorganj, (iii) BOP Dhararwa (iv) BOP Srikhandbhitta (Bhittamore) (iv) BOP Basbitta (Belwapari) under 9 <sup>th</sup> Battalion Sitamarhi (Bihar).	17.75	17.21	17.75	12.21	-5.54
65.	CISF	Establish of 10th reserve Bn.	100	55.36	77.19	55.36	-21.83
66.	ITBP	Establish of Bn. and development central	349	250	77	250	173.00
67.	BSF	For establishment of Bn. HQ. for DM Bn.(128 Bn. BSF)	85	33.060	125.00	33.06	-91.94

**Annex-4.1**  
**Adoption of incorrect rate in Preliminary Estimates**  
**(Refer para 4.1.4)**

(₹ in lakh)

S.No.	Name of the Work	Location	Name of the force	Executing Agency	No of PE	Inflated estimate amount
1.	Construction of 1 block of 4 nos. single men barrack (G+III)	Srikona, Assam	AR	NPCCL	1	6.1
2.	Construction of 32 nos. Type-II with five blocks (G+II) and 01 block in (G)	Jorhat, Assam	AR	NPCCL	1	20.13
3.	Construction of nos. Type-II (G+II) in one block with allied services and development works	Jorhat, Assam	AR	NPCCL	1	3.45
4.	Construction of one block of 4 nos. single men barrack (G+III)	Haflong, Assam	AR	NPCCL	1	7.93
5.	Construction of 72 nos. Type-II (G+III) in 9 blocks SF	Shillong, Meghalaya	AR	NPCCL	1	34.36
6.	Construction of 4 nos. single men barrack (G+II) in 1 block & (G) in 1 block with allied services and development Works	Laitkor, Meghalaya	AR	NPCCL	1	12.55
7.	Construction of one block of 3 nos. single men barrack G+II for jawans	Laitkor, Meghalaya	AR	NPCCL	1	10.32
<b>Total</b>					<b>7</b>	<b>94.84</b>

**Annex-4.2**  
**Excess provision made for Service tax**  
**(Refer para 4.1.4)**

(₹ in lakh)

S.No.	Name of Work	force	state	Executing Agency	Sanctioned est. cost	Excess provision made for Service Tax
1.	Construction of Gazetted Officers (GOs) mess/suits and Subordinate Officers (SOs) mess	CRPF	Haryana	NBCC	870.88	6.73
2.	Construction of boundary wall and main gate	CRPF	Haryana	NBCC	641.87	4.96
3.	Construction of men's club, canteen and badminton court	CRPF	Haryana	NBCC	1589.04	11.28
4.	Carrying out development and bulk services	CRPF	Haryana	NBCC	2590.29	20.03
5.	Construction of 160 nos. Type-II family quarters	CRPF	Haryana	NBCC	2571.48	19.31
6.	Construction of 236 nos. various Type quarters	CRPF	Haryana	NBCC	4501.94	28.77
7.	Construction of 240 nos. various Type quarters	CRPF	Haryana	NBCC	3858.09	29.84
8.	Acquisition of 4.75 acre of land for Bn. site at Leh, J&K	CRPF	J&K		176	-
9.	Construction of 120 men barrack	BSF	Haryana	NBCC	499	3.11
10.	Construction of 120 men barrack	BSF	Haryana	NBCC	499	3.11
11.	Construction of main entrance gate way and dormitory	BSF	Haryana	NBCC	499	3.11
12.	Construction of administration block, Srinagar	BSF	J&K	JKPCC	1293.21	-
13.	Construction of 8 nos. double story building at BSF campus in Srinagar	BSF	J&K	NBCC	385.51	-
<b>Total</b>					<b>19975.31</b>	<b>130.25</b>

**Annex- 4.3**  
**Non-including of items in Preliminary Estimates**  
**(Refer para 4.1.5)**

(₹ in lakh)

S. No.	Name of State	Particulars of Work	Name of the force	Year of sanction	Executive Agency	Amount	Date of LOI	Months given for completion	Months elapsed	Per cent of time elapsed	reason for Non start of Work
1.	Srikona (Assam)	Construction of 01 Type-VI (G+I) in one block with allied services and development works for IG HQ, AR (East) at Srikona (Assam)	Assam Rifles	2013-14	NPCCL	80	12.12.2013	15	10	66.67	Non availability of approach path
2.	Jorhat (Assam)	Construction of 02 nos. Type-V qtrs (G) in 1 block with allied services and development works for HQ 25 Sect AR at Jorhat (Assam)	Assam Rifles	2013-14	NPCCL	98	25.01.2014	15	9	60	Due to change in configuration of building by AR
3.	Jorhat (assam)	Construction of 11 nos. single JCOs (G+II) quarters, 06 units in 01 block and 05 units in 01 block (G+II) for AR with allied services and development works at Jorhat (Assam)	Assam Rifles	2013-14	NPCCL	123	18.12.2013	15	10	66.67	Non-availability of approach path
4.	Srikona/ Assam	Construction of 06 nos. Type-V quarters (G+II) in one block with allied services and development works for IGAR (East) at Srikona (Assam)	Assam Rifles	2013-14	NPCCL	326	12.12.2013	15	10	66.67	Non-availability of approach path
5.	Jorhat (Assam)	Construction of storage accommodation (G) in 1 block including works and allied services for AR at Jorhat (Assam)	Assam Rifles	2013-14	NPCCL	73	25.01.2014	15	9	60	Non-availability of approach path
<b>Total</b>						<b>700</b>					



**Annex- 4.4**  
**Non-obtaining of revised expenditure sanction**  
**(Refer para 4.2.3)**

(₹ in lakh)

Sl.No.	force	State	Particulars of the Work	Executing Agency	Amount of AA & ES	Final Exp/Up to date Exp.	Difference	Per cent
1.	CRPF	Delhi	Strengthening of existing boundary wall	CPWD	46.08	50.77	4.69	10.17
2.	CRPF	Delhi	Providing security light along with peripheral wall	CPWD	44.52	50.12	5.6	12.57
3.	BSF	West Bengal	Construction of Nalla and drain including development Work adjacent to boundary wall in rear portion of Kdamtala	CPWD	98.42	125.56	27.14	27.57
4.	NSG	Delhi	Construction of cook house Manesar	Deptt.	14.98	17.19	2.21	14.75
5.	CISF	Delhi	Electrification of 13 nos. portable huts at Mahipalpur	CPWD	10.07	16.53	6.46	64.15
6.	CRPF	TAMIL NADU	Compound wall with gate around 12 Mahila SOs dormitory and 60 women barracks	CPWD	11.49	15.59	4.1	35.68
7.	ITBP	MP	Construction of MT Complex and Workshop at Telecom Bn. Shivpuri	CPWD	125.38			
8.	CRPF	Assam	Repair by re-carpeting of road/by lanes of Group Centre, CRPF, Guwahati-23	CPWD	35.26	40.43	5.17	14.66
9.	CRPF	West Bengal	Construction of BIN Type magazine for Group Centre, CRPF, Siliguri	CPWD	40.45	55.69	15.24	37.67
10.	CRPF	West Bengal	Construction of dhobi ghat at Group Centre, CRPF, Siliguri	CPWD	16.00	27.10	11.1	69.37
11.	CRPF	West Bengal	Construction of Cycle and Motor cycle shed near Administrative Block at Group Centre, CRPF, Siliguri	CPWD	19.69	42.15	22.46	114.06
12.	CRPF	Delhi	Augmentation of 3 No. Electric Sub Station	CPWD	187	206	19	10.16

13.	CISF	MP	4 nos. drill sheds for RTC, Barwaha	CPWD	142	168.7	26.7	18.80
14.	CRPF	Chhattisgarh	Construction of BIN Type magazine Group Centre CRPF at Bilaspur	CPWD	29.79	34.23	4.44	14.90
15.	CRPF	MP	Construction of 5 nos. kote room at Group Centre, CRPF, Naya Gaon Gwlior	CPWD	45.31	62.59	17.28	38.14
16.	CISF	Rajasthan	Construction of semi-permanent structures for CISF RTC Behror	CPWD	299.5	381.79	82.29	27.47
17.	BSF	Punjab	Construction of boundary wall at BSF campus 143 Bn. BSF kmswala, Punjab	CPWD	309	495	186	60.19
18.	ITBP	Haryana	Construction of Sewage Treatment Plant at Saboli, Haryana	CPWD	71.82	81.82	10	13.92
19.	ITBP	Haryana	Construction of AT School, veterinary hospital at Bhanu, Panchkula	CPWD	88.47	98.59	10.12	11.44
20.	ITBP	Haryana	Renovation of GOs mess at Battalion HQ at Bhanu	CPWD	69	118.68	49.68	72.00
21.	CRPF	J&K	Construction of 04 nos. Nallah, RCC sump well services, administration block and quarter guard	CPWD	918.47	1017	98.53	10.72
22.	ITBP	J&K	Construction of training shed	CPWD	524	629	105	20.03
23.	SSB	Himachal Pradesh	Construction of renovation of existing bituminous internal road at Telecom Training Centre (TTC) SSB Kasumpti, Shimla.	CPWD	16	18	2	12.50
24.	SSB	Himachal Pradesh	Construction of overhead RCC tank of 50000 liter capacity at SSB Kasumpti, Shimla.	CPWD	14	22	8	57.14
25.	ITBP	Haryana	Construction of road up to firing range at BTC.	CPWD	73.2	87.27	14.07	19.22
26.	SSB	Uttra Khand	Construction of Tradesmen shop and Ware house at Frontier HQ Ranikhet.	Deptt.	19.00	21	2	10.52
27.	CRPF	Telangana	Construction of Sewerage Treatment Plant-laying of CI pipe line grid for Horticulture purpose	CPWD	44.33	50.61	6.28	14.16

28.	CRPF	Bihar	Construction of 23 nos. family quarters (T/I-2, II-12, III-7, VI-2), bulk services, main gate, guard room, development Works and boundary wall. Sector HQ, Patna, Bihar.	CPWD	361.36	407.48	46.12	12.76
29.	ITBP	Jharkhand	Construction of non-residential building for 40th Bn. ITBP, Ranchi SH: Development of site & Bulk Service.	CPWD	58.42	68.95	10.53	18.02
30.	SSB	Bihar	Construction of Type-III-24 nos., T-IV-6 nos. & T-V-2 nos. for SSB at Narkatiaganj.	CPWD	511.82	616	104.18	20.35
31.	ITBP	J&k	Construction of MT workshop at Leh.	CPWD	718	919	201	27.99
32.	CISF	MP	Re-carpeting of road in nonresidential area, Barwaha.	CPWD	27.42	53.75	26.33	96.02
33.	CRPF	Telangana	Repair/Replacement of main sewer line in non-residential area and some place at residential area of CRPF Campus, Hyderabad,	CPWD	44.33	50.61	6.28	14.16
<b>Total</b>					<b>5034.58</b>	<b>6216.58</b>	<b>1182.00</b>	

**Annex- 4.5**  
**Irregular award of Work**  
**(Refer para 4.3.2)**

(₹ in lakh)

Sl. No.	Name of Work	Executing Agency	AA&ES amount	tendered cost	Irregularity in tendering process
1.	Work of combined building for COBRA Bn. CRPF, Fudi at Khunti, Jharkhand	CPWD	696.00	696.00	NIT of the Work was floated in March 2013 without acquisition of land/availability of clear site. Work could not be completed within stipulated time-frame and was lying held till date.
2.	Renovation of toilets and kitchen of Type II and Type IV Quarters at Group Centre, CRPF, Jharoda Kalan, New Delhi	CPWD	24.06	-	The tenders were called from 20 February 2012 to 28 February 2012. But as per tender sale register, tenders were sold on March 1, 2012. The successful bidder had bought the tender on March 1, 2012 raising questions about undue favour to a bidder.
3.	Construction of semi-permanent structure on 5 acres of land allotted to NSG near Indira Gandhi International Airport	CPWD	100.00	0.091	Tenders were accepted by applying the delegation of powers changed after the opening of tenders
4.	Laying of GI pipeline from Najafgarh to CRPF Campus for supply of potable water and laying of CI pipeline for internal water supply grid;	CPWD	833	436.00	Justification was prepared incorrectly resulting in award of Work at ₹ 43 lakh higher
5.	Construction of two nos.120 Men Barrack for BSF at Kalikiri in Chittoor District, andhra Pradesh	CPWD	708.00	-	₹ 85 lakh was released on the work, without approval of modified preliminary estimates and without initiating the tender process (December, 2014) despite availability of 77.19 acres of land for this work resulted in blockage of funds of ₹ 85 lakh.
6.	08 Double story pre-fabricated structure for BSF at Humhamma, Srinagar (J&K)	CPWD	386.00	329	Out of four bidders only one bidder had the requisite Work qualification, which clearly showed defective tendering by the agency.

7.	Carrying out site development including water and sewerage pipelines, drainage Works, HT & LT substation equipments etc at Group Centre/Range HQ, CRPF Bahalgarh, Sonipat (Haryana)	NBCC	2590.00	2590.00	Work was awarded by NBCC relaxing the qualifying criteria to favour a particular contractor/bidder in 2 <sup>nd</sup> call whose bid was rejected in first call as he was not fulfilling the qualifying criteria, which was in contravention of CVC guidelines which stipulate that tendering process should be competitive & transparent.
8.	Construction of Lawn Tennis NSG, Manesar	DEPTT.	35.85	35.5	Work was awarded on single tender basis and in violation of clause of NIT he was not authorized agent of manufacturer for the current year. There was delay in supply of raw material as contractor was not authorized agent.
9.	Revovation of quater guard SSB Ghitorni, New Delhi.	DEPTT.	59.51	52.39	The NIT was issued in Newspaper on 1.8.13 and last date of submission of tender was 9.8.13 sufficient time was not provided to the contractors. The electric work was awarded to M/s Vinay Shrivastva while he was not lowest one.
10.	Construction of 102 quarters for AR at Chieswema, Nagaland	NPCCCL	1128.00	1480.00	NPCCCL invited tender with wrong web-address in April 2008 but non-receipt of bids in the first 4 bidding during April-July 2008, NPCCCL had to invite tender for the 5 <sup>th</sup> time in August 2008. work was awarded on higher rates in fifth call of tender as by that time cost index was revised in July 2008 and the higher rates quoted by the contractors were found justified by NPCCCL/AR on the basis of revised cost index of July 2008.
<b>Total</b>			<b>6560.42</b>		

**Annex - 4.6**  
**Absence of Detailed Estimates and Technical Sanction**  
**(Refer para 4.4.1)**

(₹ in lakh)

S.No.	Name of the force	Particulars of the Work	Executing Agency	Amount of Lumpsum Contract/ executed contract	Amount of D.C. paid for preparation of D.E.	Whether Completed or not
1.	AR	Construction of 01 block of 03 nos. single men barrack (G+II), black top bituminous Road and Main Drain for Assam Rifles at Laitkor, Shillong (Meghalaya)	NPCCL	154.07	0.39	Completed
2.	AR	Construction of 72 nos. Type-II SF accommodation for Assam Rifles at Laitkor (Shillong)	NPCCL	744.67	1.86	Completed
3.	AR	Construction of 01 block of 04 nos. (G+III) and Bituminous Road for Assam Rifles Bn. at Srikona Silchar	NPCCL	168.50	0.42	Completed
4.	AR	Construction of 01 block of 03 nos. single men barrack (G+II) and 01 block of 06 nos. Type -II (G+II) for No 2 Transit Camp at Jorhat (Assam).	NPCCL	188.09	0.47	Completed
5.	AR	Construction of 32 nos. Type -II quarters (SF) for Assam Rifles Bn. at Jorhat (Assam).	NPCCL	330.27	0.83	Completed
6.	AR	Construction of 03 single men barrack with allied services and development works for COE Diphu (Assam).	HPL	188.01	0.47	Completed
7.	AR	Construction of 01 blocks of 04 nos. single men barrack, 01 No JCO Mess and 01 nos. 20 bedded Hospital for Assam Rifles Battalion at Haflong (Assam).	NPCCL	404.20	1.01	Completed
8.	AR	Construction of 12 nos. Type-III quarters (G+II) and 66 nos. Type-II quarters (G+II) accommodation at Jorhat (Assam).	NPCCL	653.18	1.63	Completed
9.	AR	Construction of 08 nos. single Men barrack (G+III), 04 nos. single officers accommodation, 12 nos. single JCOs accommodation, 01 administrative block (G+I), 01 officers mess, 01 JCOs mess for Assam Rifles Bn. at Khonsa (Arunachal Pradesh).	EPIL	1545.33	3.86	Completed
10.	AR	Construction of 64 nos. Type-II (G+III) quarters for Assam Rifles Bn. at Charduar (Assam).	EPIL	617.54	1.54	Completed

11.	AR	Construction of 48 nos. Type-II (G+III) quarters for Assam Rifles Bn. at Khonsa (AP).	EPIL	528.60	1.32	Completed
12.	AR	Construction of 02 Type-V (G+I) quarters, 72 nos. Type-II quarters (G+II) and 04 nos. single officers living accommodation (G+I) for 29 Bn. Assam Rifles at Jairampur, Arunachal Pradesh	EPIL	610.59	1.53	Completed
13.	AR	Construction of 48 nos. T-II quarters and 12 nos. T-III accommodation for Assam Rifles at Jorhat	EPIL	322.34	0.81	Completed
14.	AR	Construction of 12 nos. T-III (G+II) and 54 nos. T-II G+II quarter for 43 Bn. AR at Lokra (Assam).	EPIL	459.01	1.15	Completed
15.	AR	Construction of 09 nos. single men barrack (G+II), 01 No Adm. Block (G+I) and 01 No officer mess for 43 Bn. AR at Lokra.	EPIL	419.30	1.05	Completed
16.	AR	Residential buildings support facility and internal road for KLP location of Assam Rifles at Modi (Manipur).	NPCCCL	120.04	0.30	Completed
17.	AR	Construction of 12 nos. T-II (G+II) qtrs in 02 blocks for AR at Tuensang (Nagaland).	NPCCCL	83.57	0.21	Completed
18.	AR	Construction of 08 blocks of 64 nos. Type-II Quarters (G+III) for Assam Rifles Bn. at Mokokchung (Nagaland).	NPCCCL	890.05	2.23	Completed
19.	AR	Construction of 12 nos. Type - III in (G+II) and 12 nos. Type- II quarters (G+II) for 5 Sector HQ and 78 nos. Type-II quarters (G+II) for Assam Rifles Bn. at Chieswema (Nagaland).	NPCCCL	84.70	0.21	Completed
20.	AR	Construction of 72 quarters Type-II (G+III) for AR Bn. at Kashirambasti.	NPCCCL	868.99	2.17	Completed
21.	AR	Construction of 01 Block of 03 nos. single men barracks for 06 NCOs and 60 Ors (G+II) and 01 no. Admn. Block (G+I) for 21 Assam Rifles.	NPCCCL	276.72	0.69	Completed
22.	AR	Construction of magazine building for AR	NPCCCL	96.41	0.24	Completed
23.	AR	Construction of 01 Block of 03 nos. single men barrack (G+II) and 01 Block of Cook House cum Dining Hall for AR	NPCCCL	295.73	0.74	Completed
24.	AR	Construction of 01 block of 03 nos. single men barrack (G+II) with approach road for new location of Assam Rifles.	NPCCCL	154.42	0.39	Completed
25.	AR	Construction of 06 nos. single JCOs accommodation (G+I), 01 block of 03 nos. single men barrack (G+II), 01 no. admn. block (G+I) and 01 officers mess for Sector HQ and 01 block of 03 nos. single men barrack (G+I) for A.R Bn. .	NPCCCL	895.76	2.24	Completed
26.	AR	Construction of one block of 04 nos. single men barrack (G+III) for A.R Bn. at Jwalamukhi and one block of 04 nos. single Men barrack (G+III) for A.R Bn. at Maram.	NPCCCL	429.00	1.07	Completed

27.	AR	Construction of 1 No. Type-VI (GF), 4 nos. Type-V (G+I), 13 nos. Type-III, 18 nos. Ty-II (G+2) and 2 nos. single officers accommodation with allied services.	NPCCL	677.38	1.69	Completed
28.	AR	Construction of 16 nos. Type- quarters for Assam Rifles at Agartala (Tripura).	NPCCL	201.43	0.50	Completed
29.	AR	Construction of 02 nos. Type-V quarters, 04 nos. single JCOs accommodation and 16 nos. Type-II quarters for Assam Rifles BN at Udaipur (Tripura).	NPCCL	299.62	0.75	Completed
30.	AR	Construction of 08 nos. single JCOs Accommodation (G+I) 02 Blocks of 06 nos. single men barrack (G+II) one No Adm Block 01 No. officer mess one No JCO club and internal road for 36 AR at Radhanagar.	NPCCL	565.40	1.41	Completed
31.	AR	Construction of 02 nos. T-V (G+I) 02 nos. T-IV (G+I) 12 nos. T-III 90 nos. T-II (G+II) and 06 nos. single officer accommodation for 36 AR at Radhanagar.	NPCCL	888.42	2.22	Completed
32.	AR	Construction of 06 nos. T-III (G+II) & 78 nos. T-II (G+II) for 15 AR at Teliamura.	NPCCL	769.54	1.92	Completed
33.	AR	Construction of 48 nos. Type-II and 06 nos. Type-III Quarters for Assam Rifles at Lunglie, Mizoram.	EPIL	501.55	1.25	Completed
34.	AR	Construction of 04 nos. single men barrack (G+II) in 1 block with allied services and development works for ARC & MC, Laitkor (Shillong).	NPCCL	272.74	0.68	Ongoing
35.	AR	Construction of 02 nos. Type-V (G+I) with allied services and development Works for Assam Rifles at Haflong (Assam).	NPCCL	87.45	0.22	Ongoing
36.	AR	Construction of 01 No Type-VI (G+I) quarters in one block with allied services and development works for HQ IGAR (East) at Srikona (Assam).	NPCCL	63.14	0.16	Ongoing
37.	AR	Construction of 02 nos. Type-V quarters (G) in 1 block with allied services and development works for HQ 25 Sect AR at Jorhat (Assam).	NPCCL	81.47	0.20	Ongoing
38.	AR	Construction of 11 nos. single JCOs (G+II) quarters 06 units in 01 block and 05 units in 01 block (G+II) for AR and 01 no. single men barrack (G) in 01 block for ARDB & TC with allied services and development works at Jorhat (Assam).	NPCCL	149.70	0.37	Ongoing
39.	AR	Construction of 08 nos. single officer (G+III) in one block and 07 nos. single civilian accommodations (G+III) in one block including development works and allied services for AR Bn. at Srikona (Assam).	NPCCL	206.45	0.52	Ongoing
40.	AR	Construction of 06 nos. Type-V quarters (G+II) in one block with allied services and development works for IG, AR (East) at Srikona (Assam).	NPCCL	267.72	0.67	Ongoing



41.	AR	Construction of storage accommodation. (G) in 1 block including development works and allied services for 3 works of AR at Jorhat (Assam).	NPCCL	41.86	0.10	Ongoing
42.	AR	Construction of Regimental School (G+I) in 01 block with allied services and development works for AR Bn. at Lokhra (Assam).	NPCCL	72.37	0.18	Ongoing
43.	AR	Construction of Residential School (GH+I) in 1 block with allied services and development works for AR Bn. at Haflong (Assam).	NPCCL	74.51	0.19	Ongoing
44.	AR	Construction of quarter guard, kote, armourer shop (G) in one block with allied services and development works for AR Bn. at Haflong (Assam).	NPCCL	168.70	0.42	Ongoing
45.	AR	Construction of MT accommodation in 03 blocks including allied services and development Works for AR Bn. at Haflong (Assam).	NPCCL	165.53	0.41	Ongoing
46.	AR	Construction of 10 nos. single JCOs accommodation in 02 blocks of (G+I) including infrastructural development works for AR Bn. at Jairampur (Arunachal Pradesh).	EPIL	100.08	0.25	Ongoing
47.	AR	Construction of MT accommodation with Tech stores (G+I) for AR Bn. at Khonsa (Arunachal Pradesh).	EPIL	152.39	0.38	Ongoing
48.	AR	Construction of 08 nos. Type -II (G+III) in one block with allied services and development works for AR Works at Zunheboto (Nagaland).	NPCCL	117.17	0.29	Ongoing
49.	AR	Construction of 02 nos. Type - IV (G+I) quarters with allied services and development works for AR Bn. at Wokha, Nagaland.	NPCCL	43.05	0.11	Ongoing
50.	AR	Construction of 04 block of 24 nos. Type-II (G+II) for AR Bn. at Kangvai (Manipur).	NPCCL	342.31	0.86	Ongoing
51.	AR	Construction of 08 nos. single JCOs (G+III) in one block including development works and allied services for Sector HQ AR at Tuensang (Nagaland).	NPCCL	84.70	0.21	Ongoing
52.	AR	Construction of 06 nos. Type-III (G+II) in one block including development works and allied services for AR Bn. at Kohima (Nagaland).	NPCCL	109.70	0.27	Ongoing
53.	AR	Construction of 16 nos. single JCOs accommodation (G+III) in 02 blocks with allied services land development works for AR Bn. at Naginimora (Nagaland).	NPCCL	149.68	0.37	Ongoing
54.	AR	Construction of 24 nos. Type-II quarters (G+III) in 03 blocks with allied services and development works for AR Bn. at Naginimora (Nagaland).	NPCCL	300.12	0.75	Ongoing
55.	AR	Construction of 01 No JCOs Club (G) in one blocks including development works and allied services for AR Bn. at Ghaspani (Nagaland).	NPCCL	108.28	0.27	Ongoing

56.	AR	Construction of 04 blocks of 24 nos. Type-II (G+II) for AR Bn. at Kangvai (Manipur).	NPCCL	336.60	0.84	Ongoing
57.	AR	Construction of 06 nos. Type-3 <sup>rd</sup> Quarters (G+II) in 01 block, 02 nos. Type-IV (G+I) in 01 block and 02 nos. Type V Quarters for AR. at Wokha (Nagaland).	NPCCL	44.46	0.11	Ongoing
58.	AR	Construction of Boundary Wall with RCC posts and 1.35 km. new road for AR	HPL	28.28	0.07	Ongoing
59.	AR	Construction of 01 Block of 04 nos. single Men Barrack (G+III) and 01 no. Cook House cum Dining Hall for AR	HPL	354.20	0.89	Ongoing
60.	AR	Construction of 12 nos. Ty-II qtrs. (G+II) in 02 blocks and 10 nos. Type-IV (G+I) in 5 blocks with allied services and development works for AR	NPCCL	370.29	0.93	Ongoing
61.	AR	Construction of 03 nos. single men barrack (G+II) with approach road for KLP location of AR	HPL	179.63	0.45	Ongoing
62.	AR	Construction of admn. block (G+I) including allied services and development works for A.R	NPCCL	305.12	0.76	Ongoing
63.	AR	Construction of quarter guard, Kote, armoury and arm shop including development works and internal road for AR	NPCCL	133.51	0.33	Ongoing
64.	AR	Construction of 20 bedded hospital including development Works for AR	HPL	223.20	0.56	Ongoing
65.	AR	Construction of 24 nos. Type-II quarters. including allied services and development works for IG, AR.	NPCCL	337.62	0.84	Ongoing
66.	AR	Construction of 04 nos. single officers accommodation in 1 block with allied services and development works for AR	NPCCL	72.90	0.18	Ongoing
67.	AR	Construction of 01 No. single men barrack (G) in 01 block with allied services and development works for Sector HQ, AR	NPCCL	98.20	0.25	Ongoing
68.	AR	Construction of 02 nos. Ty-V quarters. (G) in 1 block including development works and allied services for 4 works of AR	NPCCL	106.49	0.27	Ongoing
69.	AR	Construction of Housing Project-02 nos. Type-IV quarters. (G+I) in 01 block and 02 nos. Type-V quarters. (G+I) in 1 block with allied services and development works for AR	NPCCL	162.22	0.41	Ongoing
70.	AR	Construction of 24 nos. single JCOs accommodation (G+III) in 3 block with allied services and development works for AR	NPCCL	280.67	0.70	Ongoing
71.	AR	Construction of Housing Project-24 nos. Type-II quarters. (G+III) in 03 blocks with allied services and development works for AR	NPCCL	373.36	0.93	Ongoing

72.	AR	Construction of Housing Project-24 nos. Type-II quarters. (G+III) in 03 blocks with allied services and development works for AR	NPCCL	376.24	0.94	Ongoing
73.	AR	Construction of Housing Project-24 nos. Type-II quarters. (G+III) in 03 blocks with allied services and development works for AR	NPCCL	376.24	0.94	Ongoing
74.	AR	Construction of 12 nos. single J.C.O accommodation (G+II) in 2 blocks and 16 nos. Type-II quarters (G+III) in 2 blocks with allied services and development works for AR	NPCCL	390.97	0.98	Ongoing
75.	AR	Construction of Housing Project-24 nos. Type-II quarters. (G+III) in 03 blocks and with allied services and development works for AR	NPCCL	397.03	0.99	Ongoing
76.	AR	Construction of Housing Project-24 nos. Type-II quarters. (G+III) in 03 blocks and with allied services and development works for AR	NPCCL	365.45	0.91	Ongoing
77.	AR	Construction of Housing Project-02 Dwelling Units Type-V quarters in (G) configuration in 01 block.	HPL	114.34	0.29	Ongoing
78.	AR	Construction of Housing Project-16 Dwelling Units Type-II quarters. in (G+III) configuration.	HPL	268.57	0.67	Ongoing
79.	AR	Construction of 04 nos. single men barrack (G+III) including allied services and development works for A.R Bn.	HPL	359.21	0.90	Ongoing
80.	AR	Construction of 1 No. storage accommodation (G) in 1 block including development works and allied services for 4 works AR	NPCCL	52.98	0.13	Ongoing
81.	AR	Construction of one administration block in 1 block including development works and allied services for AR	NPCCL	58.67	0.15	Ongoing
82.	AR	Construction of recreation room in 1 block with allied services and development works for AR	NPCCL	65.53	0.16	Ongoing
83.	AR	Construction of quarter guard, kote, armourer shop (G) in 1 block with allied services and development works for AR	NPCCL	159.77	0.40	Ongoing
84.	AR	Construction of one no. office building. (G+I) in one block with allied services and development works for HQ, IGAR(S) AR	NPCCL	210.43	0.53	Ongoing
85.	AR	Construction of magazine building with allied services and development works for AR	NPCCL	146.95	0.37	Ongoing
86.	AR	Construction of magazine building with allied services and development works for AR	NPCCL	148.45	0.37	Ongoing
87.	AR	Construction of one. officer club in 1 block with allied services and development works for A.R Bn. .	NPCCL	266.01	0.67	Ongoing

88.	AR	Construction of two nos. Cook House cum Dining Hall (G) in 2 blocks with allied services and development works and construction of recreation room (G) in 1 block with allied services and development works.	NPCCL	212.28	0.53	Ongoing
89.	AR	Construction of 01 storage room (G) in one block with allied services and development works for AR	NPCCL	164.08	0.41	Ongoing
90.	AR	Construction of Family Welfare Centre along with allied services and development works for AR	HPL	96.02	0.24	Ongoing
91.	AR	Construction of officer club along with allied services and development works for AR	HPL	252.50	0.63	Ongoing
92.	AR	Construction of 01 No. Admn. Block (G+I) including allied services and development works for AR	HPL	330.93	0.83	Ongoing
93.	AR	Construction of 24 nos. Type-II quarters. (G+III) in 03 block with allied services and development works for AR	NPCCL	403.58	1.01	Ongoing
94.	AR	Construction of 08 nos. single officers accommodation (G+I) in 02 blocks with allied services and development works for AR	NPCCL	148.00	0.37	Ongoing
95.	AR	Construction of 72 nos. Type-II accommodation With development works and ancillary service for A.R Sector HQ/Bn. HQ.	NPCCL	935.91	2.34	Ongoing
96.	AR	Construction of 48 nos. Type-II (G+2) in 08 block and 07 nos. single JCOs accommodation with development works water supply and external electrification for AR	NPCCL	707.07	1.77	Ongoing
97.	AR	Construction of accommodation for Assam Rifles at Zokhawsang, Mizoram.	EPIL	5438.65	13.60	Ongoing
98.	AR	Construction of 06 nos. single men barracks with development works for Assam Rifles Bn. at Radhanagar (Tripura).	NPCCL	285.15	0.71	Ongoing
99.	AR	Construction of 08 nos. single JCOs accommodation. (G+III) in 1 block along with development Works and allied services for AR Bn. at Lunglei (Mizoram).	EPIL	91.65	0.23	Ongoing
100.	AR	Construction of Family Welfare Centre along with allied services and development Works for AR Bn. at Serchip (Mizoram).	EPIL	107.90	0.27	Ongoing
101.	AR	Construction of storage accommodation. (G+I) including infrastructural development Works for AR Bn. at Serchip (Mizoram).	EPIL	192.00	0.48	Ongoing
102.	AR	Construction of quarter guard/kote/armoury including infrastructural development works for AR Bn. at Lunglei (Mizoram).	EPIL	194.18	0.49	Ongoing

103.	BSF	Construction of one number 240 Men barrack for Bn. HQ. Separated family Campus at Mathura.	NBCC	950.99	2.38	Ongoing
104.	BSF	External Development Works & Bulk Services (Road Work/boundary wall/entrance gateway & dormitory block) for Campus Mathura.	NBCC	456.67	1.14	Ongoing
105.	BSF	Construction of GOs Mess with 07 suites and SOs with 04 suites for Bn. Hq. Campus Baad, Mathura (UP).	NBCC	446.54	1.12	Ongoing
106.	BSF	Construction of Store Block, Tradesman Shop & MT Complex for Bn. HQ. Separated family Campus Baad Mathura (U.P.).	NBCC	492.23	1.23	Ongoing
107.	BSF	Constructions of 90 men barrack at Sector HQ., Greater Noida.	NBCC	475.9	1.19	Ongoing
<b>Total</b>				<b>38137.37</b>	<b>95.34</b>	

**Annexure-4.7**  
**Absence of drawings and design**  
**(Refer para 4.4.1)**

S. No.	force	State	Particulars of Work	Executive Agency	Hindrence (in days )
1.	BSF	West Bengal	Construction of MT Workshop & MT park at Sector HQ, Radhabari	CPWD	45
2.	BSF	West Bengal	Construction of platoon level border out post at Shamsher	CPWD	61
3.	CRPF	West Bengal	Development of bulk service SH: Nallah & drain	CPWD	39
4.	CRPF	West Bengal	Development of bulk service SH: STP of capacity of 870 cum	CPWD	114
5.	CRPF	West Bengal	Construction of 3 No 240 men barrack at Cobra Bn. Salboni	CPWD	49
6.	CRPF	West Bengal	Construction of 222 family quarters (180 nos. Type-II)	CPWD	100
7.	CRPF	West Bengal	Construction of 20 bedded hospital for Cobra Bn. at Salboni	CPWD	203
8.	CRPF	West Bengal	Construction of BIN Type magazine for Group Centre, CRPF, Siliguri	CPWD	166
9.	BSF	West Bengal	Construction of residential quarters at Seema Nagar SH: 01 Type-V quarters.	CPWD	63
10.	BSF	West Bengal	Construction of boundary wall (7300 m) along the periphery of Signal Training Centre	CPWD	222
<b>Total</b>					<b>1062</b>

**Annex- 4.8**  
**Execution of extra item without Technical Sanction**  
**(Refer para 4.4.2)**

(₹ in lakh)

S. No.	force	Executing Agency	Name of the Work	Amount of extra item
1.	BSF	CPWD	Construction of combined drill shed for 02 units at campus Rani Nagar, Jalpaiguri.	8.47
2.	BSF	CPWD	Constructions of combined drill shed and open air theatre for Signal Training Centre,	7.96
3.	BSF	CPWD	Construction of administration block, jawan barrack and magazine kote i/c internal water supply and sanitary installation at border out post Khanjipara in Nadia district of West Bengal for 42 Bn. under Sector HQ, Krishnanagar	2.45
4.	BSF	CPWD	Construction of office block, magazine, kote, wireless block & jawan barrack at border out post Durgapur of 28 Bn. under Malda Sector HQ, Malda Ftr.	1.28
5.	BSF	CPWD	Construction of admn. block, magazine, kote, kitchen and dining hall i/c internal water supply and sanitary installation of bop dmc in Murshidabad district of West Bengal for 126 Bn. under Sector HQ kolkata.	5.68
6.	BSF	CPWD	Construction of administration block magazine, kote, kitchen and dining hall i/c in ternal water supply and sanitary installation of border out post Maluapara in Nadia district of West Bengal for 42 Bn. under Sector HQ Krishnanagar Sb. Ftr.	2.73
7.	BSF	CPWD	Construction of office block, magazine, kote, wireless block & kitchen, dining block & toilet block at border out post Chakabanshi of 57 Bn. under Sector HQ Malda, Hq Malda ftr.	0.15
8.	BSF	CPWD	Construction of magazine, kote, wireless block & kitchen, dining block & jawan barrack & toilet block at bop kestopor of 123Bn. under Sector HQ Malda, Malda Ftr.	2.11
	BSF		<b>Total</b>	<b>30.83</b>
9.	ITBP	CPWD	Water supply scheme in Lingdum 13th Bn. Lingdum	2.65
			<b>Total</b>	<b>2.65</b>
10.	CRPF	CPWD	Construction of administration block for 3rd Signal, Salt Lake, Kolkata	1.01
11.	CRPF	CPWD	Revised sanction for 224 nos. family quarters (T/II-224) at Group Centre Siliguri	173.65
12.	CRPF	CPWD	Construction of dhobi ghat at Group Centre, CRPF, Siliguri	4.97
			<b>Total</b>	<b>179.63</b>
			<b>Grand Total</b>	<b>213.11</b>

**Annex-4.9**  
**No revised Technical Sanction**  
**(Refer para 4.4.3)**

(₹ in lakh)

S. No.	force	State	Particulars of the Work	Executing Agency	Technical Saction Amount	Actual Exp.	Excess Exp.	Percentage of Excess Exp.
1.	ITBP	Uttra Khand	Construction of administration block and training block at Auli, Uttarakhand	CPWD	308.45	411.14	102.69	33.29
2.	ITBP	Uttra Khand	Development of Storm water system & drains at 12th Bn. Matli, Uttarakhand	CPWD	107.69	133.08	25.39	23.58
3.	ITBP	Uttra Khand	Construction of administration block for 1 <sup>st</sup> Bn., Uttarakhand	CPWD	223.88	279.64	55.76	24.91
4.	ITBP	Uttra Khand	Construction of quarter guard, quarter master store and MI room at Auli, Uttarakhand	CPWD	196.67	243.53	46.86	23.83
5.	ITBP	Uttra Khand	Construction of officer mess at Auli, Uttarakhand	CPWD	117.23	180.47	63.24	53.95
6.	ITBP	Uttra Khand	Construction of accommodation at ITBP Seemadwar Dehradun. SH: Construction of 200 nos. Type-I quarters and SH: Construction of 144 nos. Type-II quarters, in ITBP campus Uttarakhand	CPWD	1984.82	2335.63	350.81	17.67
7.	ITBP	Uttra Khand	Construction of quarter guard in Astel Estate of ITBP Academy Massoorie Dehradun, Uttarakhand	CPWD	189.16	243.83	54.67	28.90
<b>Total</b>					<b>3127.90</b>	<b>3827.32</b>	<b>699.42</b>	



**Annex-4.10**  
**Delay in commencement of Work**  
**(Refer para 4.5.1)**

(₹ in crore)

S. No.	Name of the Work	Year of sanction	Force	Agency	Amount of AA/ES	Tender amount	LOI date	Stipulated date of completion	Time lapsed
1.	Construction of Residential School (GH+I) in one block with allied services and development works for AR Bn. at Haflong (Assam)	2013-14	AR	NPCCL	0.95	0.82	18.12.13	15	10
2.	Construction of quarter guard, kote, armour shop (G) in one block with allied services and development works for AR Bn. at Haflong (Assam)	2013-14	AR	NPCCL	2.21	1.93	05.10.13	15	12
3.	Construction of MT accommodation in 03 blocks including allied services and development Works for AR Bn. at Haflong (Assam)	2013-14	AR	NPCCL	2.15	1.87	01.10.13	15	12
<b>Total</b>					<b>5.31</b>	<b>4.62</b>			

**Annex-4.11**  
**Payment of deviated quantities at market rates**  
**(Refer para 4.5.2)**

(₹ in lakh)

Sl.No.	Name of the work	Estimated cost	Tender amount	Name of contractor	Agreement No.	Stipulated date of commencement	Stipulated date of completion	Status of the work	No of items paid on market rate	Total amount as per agreement rate	Total amount as per market rate	Excess payment on market rate
1	2	3	4	5	6	7	8	9	10	11	12	13
1.	Construction of non-residential accommodation for office of Group commandant, quarters, Group Headquarters, Guwahati, Assam, (Block A & Block B) including development of site)	675.72	708.86	M/s O.P. Kondai & Co. Pvt. Ltd.	72/CE/EE/G CD/2009-10	18.07.2009	08.01.2011	completed	60	55.10	91.71	36.61
2.	Construction of boundary wall with 2 nos. reception post, 07 nos. watch towers for 23 <sup>rd</sup> Bn. Udalguri at Sarbaherua, Assam	224.88	308.37	M/s Guneshwar Sharma	08/EE/AAW/ D/2011-12	05.05.2011	03.05.2012	completed	11	38.56	45.48	6.92
<b>Total</b>												<b>43.53</b>

**Annex- 4.12**  
**Use of extra items without taking approvals**  
**(Refer para 4.5.3)**

(₹ in lakh)

Sl.No.	Name of Work	A.A./E.S	Estimated Cost	Tendered Amount	Final/upto date payment made to contractor	Payment made on a/c of extra items of work (₹ in lakh)
1.	Construction of Administration Block Bangrasia, Bhopal	221.45	138.50	155.44	152.79	4.95
2.	Construction of 50 Bedded Hospital at Bangrasia, Bhopal	1281.41	653.19	822.41	948.69	12.41
3.	Construction of 120 nos. Type-I quarters Indore	482.33	355.94	380.99	391.78	6.40
4.	Re-construction & strengthening of front boundary wall at Indore	96.19	88.50	92.80	100.38	11.18
5.	Construction of 501 Type-II quarters at CRPF Neemuch	4657.93	3098.21	3885.65	4423.09	51.46
6.	Construction of Boundary Wall at CRPF Neemuch	496.78	80.02	96.51	103.67	2.03
	Agmt No. 34/EE/ICD-I/2008-09		127.37	156.04	183.32	4.26
	Agmt No. 30/EE/ICD-I/2008-09		67.02	82.41	86.98	2.06
	Agmt No. 36/EE/ICD-I/2008-09		78.72	97.29	113.27	11.20
	Agmt No. 35/EE/ICD-I/2008-09					
7.	Replacement of false ceiling of main office and signal centre for 4 <sup>th</sup> Signal Bn. .., CRPF, Neemuch	44.61 (C) 14.07 (E) <b>Total 58.68</b>	33.18	33.50	39.40	1.80
8.	Construction of Permanent Morcha near all main gates and offices and other important place at Group Centre, CRPF, Neemuch	44.98	35.13	41.93	46.41	4.98
9.	Providing and erection of steel trusses and roof over open air auditorium at Academy Tekanpur	59.90	53.40	64.86	65.34	3.25
10.	Construction of security fencing 5.35 km. from Bona Gate towards widow quarters at Academy Tekanpur	59.94	49.53	65.91	36.00 (upto 2 <sup>nd</sup> RA Bill & work in progress)	1.85

11.	Construction of Security cum Boundary Wall in front of Academy house & officers colony towards N-75 at Academy Tekanpur	59.83	32.34	42.99	61.92	2.71
12.	Improvement of Type-II quarters (39 nos.) at TSU, Academy Tekanpur	60.00	46.04	60.72	29.98 (work in progress)	0.48
13.	Construction of Entrance Gate at Academy Tekanpur	59.95	51.37	65.82	65.93	1.31
14.	Renovation of GO's Mess at CRPF, Neemuch (SH: S/R to E.I. & Fans including AC unit compound lighting & service connection)	NA	73.03	96.03	NA	0.87
15.	Construction of quarters at Darya Mahal, , Barwaha	290	202.31	242.94	210.11	13.53
16.	Construction of Inspection Gallery, Barwaha	60	52.23	65.70	82.86	9.44
17.	Construction of six nos. quarters, Barwaha	168.57	106.59	132.38	135.27	5.91
18.	Construction of four nos. Drill Shed, , Barwaha	169.70	62.70	87.81	109.62	2.29
19.	Construction of collapsed compound wall, Barwaha	21.25	18.54	22.34	21.78	1.16
20.	Construction of MT Complex, ITBP, Shivpuri	125.38	91.61	96.46	125.23	3.8
					<b>Total</b>	<b>159.33</b>

## Annex- 4.13

**Delay in completion of Work/Cost overrun due to delayed execution & savings in the completed works  
(Refer para 4.5.5.1 & 4.5.6)**

*Delay in completion of Work (1 to 129+ 1 to 189+ 1 to 87= 405), cost overrun in completed works (1 to 129) and Savings in completed works (1 to 189)*

(₹ in lakh)

S.No.	Force	State	Name of Work	Executing Agency	Delay in Month	Present status as on completion of audit	Amount of AA & ES	Final Exp/Up to date Exp.	Difference
1.	SSB	Delhi	Renovation of Level-II Communication Center RK Puram New Delhi	DEPTT.	2	Completed	31.12	34.04	2.92
2.	SSB	Delhi	Construction of M.T.Guard Ghitorni	DEPTT.	11	Completed	15.63	16.94	1.31
3.	SSB	Delhi	Renovation of Computer Branch RK Puram New	DEPTT.	10	Completed	3.67	42.48	38.81
4.	SSB	Delhi	Construction of S.P. Canteen Ghitorni	DEPTT.	12	Completed	26.03	28.58	2.55
5.	BSF	Delhi	Construction of Modular Work Station	DEPTT.	2	Completed	59.08	63.08	4
6.	BSF	Delhi	Construction of office accommodation for Staff Air Wing	DEPTT.	4	Completed	58.91	64.8	5.89
7.	BSF	Delhi	Providing flooring tiles in corridors	DEPTT.	1	Completed	50.73	55.79	5.06
8.	BSF	Delhi	Renovation of Type-I quarters Chhawla	DEPTT.	14	Completed	59.68	59.95	0.27
9.	BSF	Delhi	Renovation of Type-II quarters Chhawla	DEPTT.	14	Completed	59.56	64.66	5.1
10.	CRPF	Delhi	Strengthening of existing Boundry Wall, Mahavir Nagar, New Delhi	CPWD	8	Completed	46.08	50.77	4.69
11.	CRPF	Delhi	Water Proofing Treatment, Jahroda Kalan, New Delhi	CPWD	1	Completed	28.05	29.75	1.7
12.	CRPF	Delhi	Providing security light along with peripheral Wall	CPWD	5	Completed	44.52	50.12	5.6
13.	BSF	West Bengal	Construction of nalla and drain including development work adjacent to boundary wall in rear portion of Kdamtala	CPWD	0	Completed	98.42	125.56	27.14
14.	BSF	Assam	Construction of remaining portion of boundary wall for campus at Dholchera Silchar, Assam	CPWD	32	Completed	178.69	181.89	3.2

15.	NSG	Delhi	Construction of Water Tank at NSG campus, Manesar	DEPTT.	6	Completed	39.98	42.33	2.35
16.	NSG	Delhi	Construction of Cook House at Manesar	DEPTT.	4	Completed	14.98	17.19	2.21
17.	BSF	Tripura	Construction of MI Room for Bn. HQ Campus Maharanchera under Sector HQ	CPWD	8	Completed	149.54	164.27	14.73
18.		Delhi	Renovation of Hospital Building & Physiotherapy Room by providing platform with kota stone flooring adjoining to the canteen area at Campus Saket	CPWD	8	Completed	24.59	35.69	11.1
19.		Delhi	Electrification of 13 No. Portable Huts at Mahipal Pur	CPWD	2	Completed	10.07	16.53	6.46
20.	ITBP	Delhi	Construction of boundary wall	DEPTT.	0	Completed	38.66	39.49	0.83
21.		West Bengal	Construction of administration block in West Bengal for 92 Bn. under Sector HQ Krishnanagar SBI Ftr.	CPWD	24	Completed	77.24	77.36	0.12
22.		Rajasthan	Construction of Jawan Barrack at border out post Vijeta, Binjour, Majnu & Kheruwala-64 Bn.	DEPTT.	5	Completed	57.83	63.59	5.76
23.		Rajasthan	Providing and laying chain link fencing around quarter guard	CPWD	0	Completed	28.9	31.63	2.73
24.		Rajasthan	Developing of Rain Water Harvesting System at Campus Regional Training Centre-I Deoli, Rajasthan	CPWD	0	Completed	23.02	29.85	6.83
25.		Rajasthan	Construction of residual work at Ceremonial Parade Ground	CPWD	0	Completed	42.05	45.86	3.81
26.		Rajasthan	Construction of Boundary Wall around cemetery ground	CPWD	NA	Completed	18.67	20.07	1.4
27.	CRPF	Rajasthan	Maintenance and aesthetic improvement of Masuda House	CPWD	4	Completed	27.04	27.62	0.58
28.	CRPF	Gujarat	Strengthening of existing compound wall and construction of new compound wall in place of damaged part of the compound wall around the campus of G.C. CRPF at Gandhinagar.	CPWD	3	Completed	58.21	60.31	2.1
29.	CRPF	Gujarat	Construction of 3 mtr. wide kachcha peripheral road for patrolling along the compound wall at G.C. CRPF Campus, Gandhinagar.	CPWD	10	Completed	53.08	54.79	1.71

30.		Gujarat	Construction of 04 nos. deficient GOs mess	DEPTT.	31	Completed	32.76	46.67	13.91
31.		Gujarat	Construction of 03 nos. of magazine building for 133 (Now 107) Bn. under Sector HQ., Gandhinagar, Gujarat	DEPTT.	14	Completed	23.78	31.85	8.07
32.	CRPF	Assam	Construction of 33 KV Sub Station & Electric Sub Station rooms at Training Area & Gate No.3.	CPWD	21	Completed	164.87	169.35	4.48
33.	CRPF	Tripura	Construction of boundary wall with two main gates, watch towers 6 nos., and sentry posts 18 nos.	CPWD	13	Completed	328.65	405.66	77.01
34.	BSF	Tamil Nadu	Construction of Guard Room	DEPTT.	8	Completed	15.39	16.11	0.72
35.	BSF	Tamil Nadu	Providing false ceiling, vitrified tiles and misc. works at GOs mess	CPWD	NA	Completed	14.08	14.77	0.69
36.	CRPF	Tamil Nadu	Compound wall with gate around 12 mahila SOs dormitory and 60 women barracks	CPWD	5	Completed	11.49	15.59	4.1
37.	ITBP	Arunachal Pradesh	Construction of water bound macadam road & re-carpeting of road at 9th Bn. Lohitpur	CPWD	15	Completed	193.16	257.85	64.69
38.	ITBP	Arunachal Pradesh	Construction of boundary wall with elevated watch tower, guard room and sentry post with gate at Mohanbari.	CPWD	8	Completed	175.23	181.18	5.95
39.	SSB	Arunachal Pradesh	Construction of Type-V-02 nos. residential quarters at 38 <sup>th</sup> Bn. Tawang	CPWD	5	Completed	140.62	366.39	225.77
40.	SSB	Arunachal Pradesh	Construction of Type-IV-06 nos. quarters at 38th Bn. Tawang	CPWD	23	Completed	218.01	366.39	148.38
41.	CISF	Delhi	Construction of 144 Girls Hostels at Shastri Park	DMRC	29	Completed	306	354.72	48.72
42.	BSF	MP	Strengthening of front boundary wall gates and guard rooms at CSWT Indore.	CPWD	4	Completed	96.19	102.42	6.23
43.	CRPF	Assam	Repair by re-carpeting of road/by lanes of Group Centre, CRPF, Guwahati	CPWD	3	Completed	35.26	40.43	5.17
44.	SSB	Assam	Construction of 01 No. residence for Commandant + one officer at 33rd Bn. Rangia	DEPTT.	21	Completed	16.30	16.45	0.15
45.	SSB	Arunachal Pradesh	Repair and re-carpeting of internal bituminous road and water bound macadam road at 34th Bn. Dirang	DEPTT.	0	Completed	14.13	15.44	1.31

46.	SSB	Arunachal Pradesh	Construction of garage for medium and heavy vehicles at 38th Bn. Tawang	DEPTT.	1	Completed	22.75	25.02	2.27
47.	AR	Arunachal Pradesh	Provision of 81 MM Motor Simulator for 18 Assam Rifles at Jairampur	DEPTT.	8	Completed	55.93	58.12	2.19
48.	CRPF	West Bengal	Construction of BIN Type magazine for Group Centre, CRPF, Siliguri	CPWD	11	Completed	40.45	55.69	15.24
49.	CRPF	West Bengal	Flood damage repair (BP 358 MP To BP 357 MP)	CPWD	1	Completed	23.57	42.32	18.75
50.	CRPF	West Bengal	Construction of dhobi ghat at Group Centre, CRPF, Siliguri	CPWD	10	Completed	16.00	27.10	11.1
51.	CRPF	West Bengal	Construction of cycle and motor cycle shed near administrative block at Group Centre, CRPF, Siliguri	CPWD	0	Completed	19.69	42.15	22.46
52	AR	Manipur	Construction of 5 nos. temporary structures for communication set up and establishment of 140 Bn. of under Sector HQ Ci (Ops), Manipur	DEPTT.	7	Completed	36.36	63.78	27.42
53	AR	Mizoram	Construction of recreation room for HQ 23 Sector AR at Khatla, Aizawl	DEPTT.	2	Completed	54.00	56.65	2.65
54	AR	Tripura	Provision of surge protection for signal exchange and magazine building of 35 AR at Agartala	DEPTT.	15	Completed	23.02	24.44	1.42
55	CRPF	Maharashtra	Construction of 3 nos. 120 men barracks	CPWD	13	Completed	599.47	637.92	38.45
56	CRPF	Delhi	Augmentation of 3 nos. Electric Sub Station	CPWD	16	Completed	187	206	19
57	CRPF	Delhi	Construction of Boundary Wall Wazirabad	CPWD	5	Completed	217	227	10
58	CRPF	Delhi	Construction of Type-II, 288 family quarters Greater Noida	NBCC	64	Completed	1411	2358	947
59		MP	4 nos. Drill Sheds for Regional Training Centre, Barwaha	CPWD	6	Completed	142	168.7	26.7
60	CRPF	MP	Repair and renovation of GOs Mess (Ochtorlony House)	CPWD	0	Completed	82.95	89.57	6.62
61	CRPF	MP	Construction of Boundary Wall at Group Centre, CRPF, Neemuch	CPWD	0	Completed	496.78	500.17	3.39
62	CRPF	MP	Construction of 501 nos. T/II Family quarters. at Group Centre Neemuch	CPWD	8	Completed	4657.93	4896.82	238.89



63	CRPF	Chhattisgarh	Construction of BIN Type Magazine Group Centre CRPF at Bilaspur	CPWD	7	Completed	29.79	34.23	4.44
64	CISF	MP	Construction of Collapsed Compound Wall Near WT Ground for, Regional Training Centre (RTC) Barwaha	CPWD	0	Completed	21.25	22.93	1.68
65	BSF	MP	Entrance Gate at Academy, Tekanpur	DEPTT.	11	Completed	59.94	65.93	5.99
66	BSF	MP	Providing & erection of Steel Trusses and Roof Over Open Air Auditorium at Academy	DEPTT.	4	Completed	59.89	65.75	5.86
67	BSF	MP	Security Cum Boundary Wall in front of academy house and officers colony towards NH-75	DEPTT.	8	Completed	59.83	62.08	2.25
68	CRPF	MP	Construction of permanent Morcha near all main gate/office/important place for Group Centre CRPF Neemuch	CPWD	10	Completed	44.98	46.41	1.43
69	CRPF	MP	Construction of 03 nos. open wells for RTC Neemuch	CPWD	0	Completed	44.97	45.53	0.56
70	CRPF	MP	Replacement of false ceiling of main office and Signal Centre of 4 Signal Bn. .	CPWD	8	Completed	44.61	48.94	4.33
71	CRPF	MP	Renovation of Kanetkar Barrack No. 1 & 2 CTC, CRPF, Neemuch	CPWD	0	Completed	44.76	48.73	3.97
72	CRPF	MP	Construction of 5 nos. kote room at Group Centre, CRPF, Naya Gaon Gwalior	CPWD	2	Completed	45.31	62.59	17.28
73	ITBP	MP	Augmentation of Water Supply System of RTC Campus through rain water harvesting, RTC, ITBP, Karera	DEPTT.	0	Completed	59.5	59.81	0.31
74	ITBP	MP	Construction of 01 (One) Double Storey Building for Administration Staff at RTC, ITBP, Karera	DEPTT.	0	Completed	55.53	59.02	3.49
75	BSF	Rajasthan	Construction of 1 no. 120 men barrack including development works at 84 Bn. Campus-I located at Sum Road Jaisalmer.	CPWD	21	Completed	165.78	207.74	41.96
76	BSF	Gujarat	Construction of small arm workshop at Ftr. HQ, at Gandhinagar.	CPWD	NA	Completed	162.84	213.53	50.69
77	CISF	Rajasthan	Construction of semi-permanent structures for Regional Training Centre (RTC) Behror.	CPWD	7	Completed	299.5	381.79	82.29

78	SSB	Rajasthan	Construction of residential building and non-residential building at Reserve Bn. HQ Maujpur (Alwar).	NBCC	0	Completed	3940.31	4194.33	254.02
79	ITBP	Karnataka	Construction of Boundary Wall	CPWD	8	Completed	389	539	150
80	BSF	Karnataka	Providing internal roads, culverts, storm water drains etc.	CPWD	3	Completed	492	573	81
81	CISF	Rajasthan	02 nos. of 180 Men Barracks	CPWD	22	Completed	499.49	708.18	208.69
82	CISF	Rajasthan	Construction of 107 quarters (TII 84, TIII 20, TIV 02 and TV 01) for RTC	CPWD	38	Completed	857.02	877.03	20.01
83	CISF	Rajasthan	Construction of non-residential buildings	CPWD	7	Completed	1078.4	2268.55	1190.15
84	CISF	Rajasthan	Construction of family welfare centre	CPWD	10	Completed	180.52	181.17	0.65
85	CRPF	Rajasthan	Providing & fixing wire mesh doors & windows in 386 nos. various Types of old family quarters (T/I-84, T/II-290 & T/III-12)	CPWD	4	Completed	98.97	100.13	1.16
86	BSF	Maharashtra	Construction of Water Closet (WC) Block of 10 seated for each company A,B,C,D,E HQ at STC, Chakur	Deptt. I	17	Completed	28.19	36.47	8.28
87	CRPF	Karnataka	Construction of 208 nos. Type-II family qtrs.	CPWD	11	Completed	1229	1430	201
88	CRPF	Delhi	Approach Road To Connect Group Centre from Main Village Road Kadarpur	CPWD	0	Completed	65.29	78.34	13.05
89	CRPF	J&K	Construction of 117 nos. family quarters	CPWD	9	Completed	396	577	181
90	SSB	H.P	External Water Supply Scheme for SSB TC Sarahan including construction of sedimentation, filtration and storage tank and development of site.	CPWD	7	Completed	119	125	6
91	ITBP	J&K	Construction of three nos. administration block	CPWD	10	Completed	998	1004	6
92	CRPF	J&K	Construction of 3 nos. 180 men barracks	CPWD	NA	Completed	873.00	1372	499
93	CRPF	J&K	Construction of four nos. Nallah RCC sumpwell services, administration block and quarter guard	CPWD	11	Completed	918.47	1017	98.53
94	CISF	Tamil Nadu	Construction of 100 mtr. Baffle Range at RTC Arakkonam	CPWD	23	Completed	218.84	295.28	76.44

95	BSF	U.P.	Construction of 02 nos. Toilet Block at 97 Bn. Lucknow.	Deptt.	3	Completed	11	12	1
96	CISF	Tamil Nadu	Indoor Sports Complex for RTC	CPWD	NA	Completed	329.15	334.77	5.62
97	CRPF	Tamil Nadu	Revised Sanction Issued for construction of boundary wall with barbed wire fencing for additional area obtained after re-survey	CPWD	13	Completed	218.84	295.25	76.41
98	CRPF	Tamil Nadu	Construction of Recreation Hall	CPWD	10	Completed	95.42	129.35	33.93
99	CRPF	Tamil Nadu	Providing mosquito proof door shutter in 4 nos.60 men barracks, SOs dormitory & one women barrack	CPWD	NA	Completed	96.78	99.2	2.42
100	CRPF	Kerala	Replacement of overhead electric lines with UG cables at Group Centre, CRPF, Pallipuram, Trivandrum	CPWD	66	Completed	69.54	94.49	24.95
101	CISF	Odisha	Construction of ten Bedded Hospital for RTC	CPWD	42	Completed	120	162.55	42.55
102	CRPF	Odisha	Construction of 269 nos. family quarters (T/II-227, III-27, IV-14 & V-1) for 202 Cobra Bn. , Koraput	CPWD	6	Completed	3121.28	3193.04	71.76
103	SSB	U.P.	Construction of prefabs structures at Lakhimpur Kheri.	Deptt.	2	Completed	60	63	3
104	ITBP	Uttarakhand	Construction of Admn. Block and Trg. Block at Auli	CPWD	NA	Completed	439	453	14
105	ITBP	Uttarakhand	Development of Storm Water System & Drains at 12th Bn. Matli	CPWD	14	Completed	149	193	44
106	ITBP	Uttarakhand	Augmentation of Water Supply Line at Seemadwar Dehradun	CPWD	NA	Completed	63	68	5
107	ITBP	Uttarakhand	Providing Chain Link fencing at Malari Post	DEPTT.	0	Completed	51	55	4
108	ITBP	Uttarakhand	Providing water proofing treatment applying weather code on outer walls and construction of at 23rd Bn. Dehradun	DEPTT.	0	Completed	40	42	2
109	CISF	Odisha	Construction of Fort wall for RTC	CPWD	31	Completed	87.87	133.27	45.4
110	SSB	Uttarakhand	Construction of barbed wire fencing at Bn. HQ Champawat.	DEPTT.	20	Completed	40.00	44	4
111	SSB	Uttarakhand	Construction of Tradesmen Shop and Ware House at Frontier HQ Ranikhet	DEPTT.	14	Completed	19.00	21	2

112	CRPF	Bihar	Construction of 23 nos. family quarters (T/I-2, II-12, III-7, VI-2), bulk services, main gate, guard room, development works and boundary wall Sector HQ, Patna, Bihar	CPWD	21	Completed	361.36	407.48	46.12
113	ITBP	Jharkhand	Providing & fixing of 4 nos. pre-fabricated huts of size 19.52 Mx6.1 M including 1.525 m veranda & attached 5 nos. water closet (WC) and 4 nos. bath for each hut for ITBP, Ranchi SH: Supply and erection of pre-fabricated huts.	CPWD	0	Completed	27.12	28.18	1.06
114	ITBP	Jharkhand	Construction of non-residential building for 40th Bn. ITBP, Ranchi SH: Development of site & bulk service (civil & electrical) SW: Construction of 100000 Litre Capacity RCC Elevated Service Reservoir for Water and Underground Sump	CPWD	0	Completed	58.42	68.95	10.53
115	CRPF	Bihar	Construction of SOs Mess & Others Mess (4 Storied) for IG/DIGP Bihar Sector, CRPF at Digha, Sector HQ, Patna, Bihar	CPWD	39	Completed	314	505	191
116	CRPF	Bihar	Construction of 15 nos. T-I-2, T-II-7, T-III-5 & T-IV-one Sector HQ, Patna, Bihar	CPWD	13	Completed	104	110	6
117	CRPF	U.P.	Construction of women barracks for 104th Bn. RAF Aligarh	CPWD	0	Completed	88	94	6
118	CRPF	U.P.	Construction of 250 nos. family quarters (T/II-240, IV-8, V-2) Group Centre Allahabad.	CPWD	7	Completed	1809	1888	79
119	SSB	Bihar	Construction of Type-III-24 nos., T-IV-6 nos. & T-V-2 nos. for SSB at Narkatiaganj.	CPWD	20	Completed	511.82	616	104.18
120	CRPF	U.P.	Construction of 15 nos. watch towers & guard rooms Rampur	CPWD	0	Completed	50	53	3
120	BSF	Kerala	Construction of 2 nos. magazine for 163 Bn., Thrissur	DEPTT.	8	Completed	45.8	49.6	3.8
122	BSF	Kerala	Construction of Type-V quarters at Sector HQ, Muttathara, Trivandrum	DEPTT.	17	Completed	49.11	53.83	4.72

123	CRPF	U.P.	Construction of boundary wall & 2 nos. watch towers with guard rooms & providing with concertina wire on top in front of 6.5 acres land for security reasons Rampur	CPWD	8	Completed	69	72	3
124	BSF	Karnataka	Providing and fixing wire gauge shutters to doors and windows of existing Type ii quarters (71 numbers); Type iii (10 numbers); Type iii cottages (03 numbers) and Type iv (07 numbers) at STC, , Bengaluru	Depatmental	0	Completed	26.82	29.18	2.36
125	BSF	Karnataka	Construction of light/ medium and heavy vehicle garage for 82nd Battalion, at Karahalli	Depatmental	19	Completed	59.96	65.68	5.72
126	ITBP	Karnataka	Construction of semi-permanent SOs Mess, at 44th Battalion, ITBP, Belgaum	Depatmental	0	Completed	39.45	41.29	1.84
127	ITBP	Karnataka	Construction of 02 numbers semi-permanent kitchen and dining hall for others at 44th Battalion, ITBP, Belgaum	Depatmental	0	Completed	30.67	33.68	3.01
128	CRPF	Telangana	Renovation of 16 nos. new Type-IV residential quarters (quarter no.13 to 28) at Group Centre, CRPF, Hyderabad	CPWD	12	Completed	29.75	51.10	21.35
129	CISF	MP	Re-carpeting of roads in non-residential area, Barwaha	CPWD	8	Completed	27.42	53.75	26.33
<b>Total</b>							<b>33588.41</b>	<b>39890.84</b>	<b>6302.43</b>
1.	CRPF	Delhi	Construction of approach road to parade ground, Kadarpur, Gurgaon	CPWD	3	Completed	59.76	40.28	-19.48
2.	CRPF	Delhi	Construction of 10 Squad Post, Kadarpur, Gurgaon	CPWD	5	Completed	53.33	51.41	-1.92
3.	AR	Manipur	Construction of 06 nos. Type III (G +II) and 48 nos. Type II quarters. (G+II) for 19 AR at Shangshak.	NPCCL	45	Completed	528.13	435.94	-92.19
4.	AR	Assam	Construction of 12 nos. T-III (G+II) and 54 nos. T-II G+II quarter for 43 AR at Lokra (Assam)	EPIL	25	Completed	587.46	498.17	-89.29
5.	AR	Assam	Construction of 09 nos. singe men barrack (G+II), 01 No Admn. Block (G+I) and 01 No Officer Mess for 43 AR at Lokra.	EPIL	NA	Completed	552.16	454.38	-97.78
6.	BSF	West Bengal	Construction of MT Workshop & MT Park for Sector HQ Siliguri at Radhabari Under Nb Ftr .	CPWD	9	Completed	491.36	298.71	-192.65

7.	BSF	West Bengal	Construction of combined drill shed for 02 unit at Campus Raninagar, Jalpaiguri.	CPWD	14	Completed	222.58	178.28	-44.3
8.	NSG	Delhi	Construction of toilet dwelling unit in Manesar.	DEPTT.	3	Completed	59.98	44.69	-15.29
9.	NSG	Delhi	Construction of Lawn Tennis Manesar	DEPTT.	7	Completed	35.85	34.88	-0.97
10.	NSG	Delhi	Construction of Operation Room at Mahram Nagar, New Delhi	DEPTT.	24	Completed	34.43	32.19	-2.24
11.	BSF	Tripura	Construction of SOs mess with four nos. suits	CPWD	0	Completed	145.09	139.57	-5.52
12.	BSF	Mizoram	Construction of Type-V-1 No quarters at Campus, Lunglei (Mizoram) under Sector HQ, Aizawl, Ftr. HQ	CPWD	21	Completed	76.56	71.01	-5.55
13.	BSF	West Bengal	Construction of administration block, jawan barrack and magazine kote including internal water supply and sanitary intallation at bop khajipara in Nadia district of West Bengal for 42 Bn. under Sector HQ, Krishna Nagar	CPWD	6	Completed	77.25	75.87	-1.38
14.	CISF	Delhi	Construction of potable huts for kitchen and ration store for Mess at Mahipal Pur	CPWD	3	Completed	21.07	20.67	-0.4
15.	ITBP	Delhi	Construction of Sitting Gallery for force Person	DEPTT.	3	Completed	36.14	26.87	-9.27
16.	ITBP	Delhi	Construction of Sitting Gallery for VIP Person	DEPTT.	3	Completed	36.17	26.64	-9.53
17.	ITBP	Delhi	Construction of Toilet & Bath Room.	DEPTT.	4	Completed	12.61	12.03	-0.58
18.	BSF	West Bengal	Construction of office Block, Magazine, Kote, Wireless Block & Jawan Barrack at border out post Durgapur of 28 Bn. under Malda Sector HQ, Malda Ftr.	CPWD	5	Completed	103.15	82.25	-20.9
19.	BSF	West Bengal	Construction of kitchen, dining block, jawan barrack & toilet block at border out post Kanchantar of 123 Bn. under Malda Sector HQ, Malda Ftr..	CPWD	4	Completed	61.26	57.24	-4.02
20.	BSF	West Bengal	Construction of Administration Block Magazine, Kote, Kitchen and Dining Hall including in Ternal Water Supply and Sanitary Installation of border out post in Murshidabad District of West Bengal for 126 Bn. under Sector HQ Kolkata, South Bengal Ftr	CPWD	8	Completed	59.59	55.67	-3.92

21.	AR	Assam	Construction of 48 nos. T-II quarters. and 12 nos. T-III separated family accommodation for Assam Rifles at Jorhat	EPIL	42	Completed	611.34	375.89	-235.45
22.	AR	Arunachal Pradesh	Construction of 02 Type-V (G+I) quarters, 72 nos. Type-II quarters (G+II) and 04 nos. single officers Living accommodation (G+I) for 29 Assam Rifles at Jairampur (Arunachal).	EPIL	28	Completed	773.69	621.80	-151.89
23.	AR	Nagaland	Construction of 03 Block of 09 nos. single men barrack (for 18 ncos and 180 ors) (g+iii), 01 no administrative block, 01 Officers Mess, 01 No JCO.	NPCCL	38	Completed	704.48	577.31	-127.17
24.	BSF	West Bengal	Construction of Administration Block Magazine, Kote, Kitchen and Dining Hall including In Ternal Water Supply and Sanitary Installation of border out post Natna in Nadia District of West Bengal for 92 Bn. under Sector HQ Krishnanagar	CPWD	10	Completed	77.25	32.63	-44.62
25.	BSF	West Bengal	Construction of Administration Block Magazine, Kote, Kitchen and Dining Hall including in Ternal Water Supply and Sanitary Installation of border out post Maluapara in Nadia District of West Bengal for 42 Bn. under Sector HQ Krishnanagar	CPWD	9	Completed	77.25	74.53	-2.72
26.	BSF	West Bengal	Construction of Jawan Barrack & Magazine Kote at border out post Chandichak of 151 Bn. Under Sector HQ Berhampore	CPWD	10	Completed	95.93	9.13	-86.8
27.	BSF	West Bengal	Construction of office Block, Magazine Kote, Wireless Block & Kitchen, Dining Block & Toilet Block at border out post Chakabanshi of 57 Bn. under Sector HQ Malda, HQ Malda Ftr .	CPWD	7	Completed	90.07	71.13	-18.94
28.	BSF	West Bengal	Construction of Magazine, Kote, Wireless Block & Kitchen, Dining Block & Jawan Barrack & Toilet Block at border out post Kestopur of 123 Bn. under Sector HQ Malda, HQ. Malda Ftr .	CPWD	9	Completed	92.72	81.00	-11.72
29.	BSF	West Bengal	Construction of Magazine, Kote, Wireless Block & Jawan Barrack at border out post Domutha of 69 Bn. Under Sector HQ Malda, HQ Malda Ftr .	CPWD	4	Completed	72.38	57.99	-14.39

30.	BSF	West Bengal	Construction of 06 nos. Double Storied Pre- Fab Structures at STC North Bengal	NBCC	9	Completed	289.13	220.14	-68.99
31.	BSF	Assam	Construction of RCC overhead tank of 1.5 lac liters capacity, 3 lacs liters capacity underground sump, boring of deep tube well, iron removal filtration plant and laying of water supply line from overhead to existing line at Campus Patgaon, Guwahati (Assam).	CPWD	9	Completed	182.66	1.99	-180.67
32.	BSF	Rajasthan	Construction of Jawan Barrack, Cook House Cum Dining Hall, Administration Block and Kote Store & Magazine Block at border out post Jagdev of 66 Bn.	DEPTT.	0	Completed	39.38	38.59	-0.79
33.	BSF	Rajasthan	Improvement of Type-I (44 nos.) quarters at FTR HQ Rajasthan	DEPTT.	28	Completed	38.96	19.78	-19.18
34.	BSF	Rajasthan	Re-carpeting of Drill Square Parade Ground at STC Jodhpur	DEPTT.	0	Completed	47.24	28.39	-18.85
35.	CISF	Rajasthan	Providing street light from C Coy to Neck Chal Temple, CPWD office to Ajmeri Gate and Ajmeri Gate To War Memorial	CPWD	2	Completed	38.26	20.03	-18.23
36.	CRPF	Rajasthan	Renovation of Type-II quarters. No. 01 To 48 at Group Centre-I, Ajmer.	CPWD	6	Completed	58.44	57.11	-1.33
37.	CRPF	Rajasthan	Development of Two No's Children Park In residential area at CRPF	CPWD	9	Completed	54.36	43.97	-10.39
38.	CRPF	Rajasthan	Development of existing pond	CPWD	2	Completed	44.08	38.35	-5.73
39.	CRPF	Rajasthan	Renovation of toilets of barrack No. 1 to 5	CPWD	0	Completed	46.61	43.32	-3.29
40.	CRPF	Gujarat	Re-carpeting of internal roads at G.C. CRPF, Gandhinagar.	CPWD	0	Completed	44.98	42.66	-2.32
41.	CRPF	Gujarat	Construction of BIN Type Magazine Building for 100 Bn., R.A.F. Vastral, Ahmedabad	CPWD	6	Completed	30.32	25.2	-5.12
42.	CRPF	Gujarat	Construction of Grain Godown Cum Shopping Centre for 100 Bn. , CRPF, Rapid Action Force, Vastral, Ahmadabad	CPWD	7	Completed	36.48	33.98	-2.5
43.	BSF	Gujarat	Construction of 209 nos. residential quarters for Campus at Gandhidham.	CPWD	1	Completed	40.1	38.52	-1.58



44.	AR	Mizoram	Construction of 48 nos. Type-II and 06 nos. Type-III quarters for Assam Rifles at Lunglie.	EPIL	10	Completed	674.07	647.08	-26.99
45.	CRPF	Assam	Providing and fixing wire gauge shutters in residential and non-residential building, 344 nos. T/I and 16 nos. T/II quarters & 7 nos. barracks	CPWD	1	Completed	94.80	84.56	-10.24
46.	CRPF	Tripura	Construction of 26 nos. family quarters (T/II-18, T/III-6 & T/IV-2)	CPWD	4	Completed	411.55	396.00	-15.55
47.	ITBP	Arunachal Pradesh	Construction of 02 nos. deep bore well for 9th Bn. Lohitpur (T-I) 01 no. for 25 Bn. ITBP, Tezu, Arunachal Pradesh	CPWD	1	Completed	59.06	21.56	-37.5
48.	CISF	Tamil Nadu	Re-surfacing of internal roads in RB Area	CPWD	NA	Completed	57.38	53.21	-4.17
49.	CRPF	Tamil Nadu	Construction of guard room near GOs Mess	CPWD	10	Completed	27.9	20.45	-7.45
50.	CRPF	Tamil Nadu	Construction of compound wall for Type-VI family quarters	CPWD	4	Completed	20.43	19.94	-0.49
51.	CRPF	Tamil Nadu	Providing approach road to all 4 numbers newly construction of ducted drill shed at Regional Training centre (RTC) Avadi	CPWD	0	Completed	24.11	19.52	-4.59
52.	ITBP	Tamil Nadu	Construction of semi-permanent store building at 45 Bn. ITBP	DEPTT.	2	Completed	19.02	18.51	-0.51
53.	ITBP	Tamil Nadu	Construction of semi-permanent Type GOs Mess with provision of drawing room dining hall, kitchen pantry and store	DEPTT.	6	Completed	42.81	37.73	-5.08
54.	ITBP	Arunachal Pradesh	Construction of Training Shed at Lohitpur	CPWD	NA	Completed	115.35	105.61	-9.74
55.	ITBP	Arunachal Pradesh	Construction of MT Garage & Work Shop at Sector HQ, Itanagar	CPWD	29	Completed	298.51	278.09	-20.42
56.	ITBP	Arunachal Pradesh	Construction of GOs Mess & single officer accommodation at 25th Bn. Tezu, Arunachal Pradesh	CPWD	17	Completed	267.46	1.35	-266.11
57.	ITBP	Assam	Installation of filtration plant, covering of open area and additional horticulture work at transit camp for ITBP Jhalukbari, Guwahati.	CPWD	13	Completed	76.52	25.94	-50.58

58.	NSG	West Bengal	Construction of boundary wall at Regional Centre Kolkata.	CPWD	33	Completed	471.78	195.63	-276.15
59.	SSB	Assam	Construction of T-III/8 (Three Storied) at 33rd Bn. Rangia.	CPWD	2	Completed	179.08	124.98	-54.1
60.	SSB	Assam	Construction of boundary wall with 7 nos. watch tower at Bn. HQ Sarbahure (Bhairabkunda).	CPWD	8	Completed	348.61	316.97	-31.64
61.	SSB	Assam	Construction of SOs Mess for 23rd Bn. at village Sarbeherua (Udalguri)	CPWD	29	Completed	133.86	107.85	-26.01
62.	SSB	Assam	Construction of Quarter Guard Building for 23rd Bn. at village Sarbeherua (Udalguri).	CPWD	29	Completed	246.05	92.77	-153.28
63.	SSB	Assam	Construction of Tradesmen Shop at village Sarbeherua (Udalguri).	CPWD	12	Completed	74.34	67.83	-6.51
64.	AR	Manipur	Construction of Magazine Building for AR Bn. at Kakching.	NPCCL	21	Completed	203.99	190.63	-13.36
65.	AR	Nagaland	Construction of 12 nos. T-II (G+II) quarters in 02 blocks for AR at Tuensang (Nagaland)	NPCCL	0	Completed	347.00	303.00	-44
66.	AR	Manipur	Construction of 01 Block of 03 nos. single men barrack (G+II) and 01 block of Cook House Cum Dining Hall for AR BN at Phundrei	NPCCL	14	Completed	446.02	423.74	-22.28
67.	AR	Assam	Construction of 01 Block of 04 nos. single men barrack (G+III) and bituminous road for Assam Rifles Bn. at Srikona Silchar	NPCCL	1	Completed	474.72	359.00	-115.72
68.	AR	Manipur	Construction of 03 nos. single men barrack (G+II) with approach road for Assam Rifles at Kangvai (Manipur)	NPCCL	34	Completed	488.98	379.00	-109.98
69.	AR	Manipur	Construction of 04 block of 24 nos. Type-II (G+II) for AR Bn. at Kangvai (Manipur)	NPCCL	9	Completed	481.16	65.55	-415.61
70.	AR	Tripura	Construction of 06 nos. single men barracks with development woks for Assam Rifles Bn. at Radhanagar (Tripura)	NPCCL	10	Completed	364.52	264.61	-99.91
71.	AR	Assam	Construction of 02 nos. Type-V (G+1) with allied services and development works for Assam Rifles at Haflong (Assam)	NPCCL	12	Completed	195.03	55.97	-139.06

72.	AR	Nagaland	Construction of 06 nos. Type-III quarters (G+II) in 01 block, 02 nos. Type-IV (G+I) in 01 Block and 02 nos. Type-V quarters for AR Bn. at wokha (Nagaland)	NPCCL	0	Completed	496.00	355.00	-141
73.	AR	Nagaland	Construction of 16 nos. single JCOs accommodation (G+III) in 02 blocks with allied services and land development work for AR Bn. at Naginimora, Nagaland	NPCCL	NA	Completed	178.71	96.66	-82.05
74.	AR	Nagaland	Construction of 14 nos. single JCOs (G+III) in one block with allied services and and development work for AR Bn. at Zunheboto, Nagaland	NPCCL	9	Completed	188.79	54.49	-134.3
75.	AR	Meghalaya	Construction of 04 nos. single men barrack (G+II) In 1 with allied services and land development work for ARC & MC, Laitkor (Shillong)	NPCCL	NA	Completed	364.53	152.89	-211.64
76.	CRPF	Assam	Construction of SOs Mess/ Dormitory for 210 Cobra Bn., Dalgaon	CPWD	21	Completed	659.78	103.13	-556.65
77.	SSB	Assam	Construction of permanent infrastructure at Bn. HQ SSB Gossaigaon	CPWD	11	Completed	1,348.38	13.61	-1334.8
78.	AR	Assam	Construction of 01 block of 04 nos. single men barrack, 01 No JCO Mess and 01 no. 20 Bedded Hospital for Assam Rifles Battalion at Haflong (Assam)	NPCCL	10	Completed	597.28	492.47	-104.81
79.	AR	Nagaland	Construction of 07 km. internal road for Assam Rifles Training Centre and School at Sukhovi (Nagaland)	HPL	26	Completed	1,387.02	829.00	-558.02
80.	AR	Manipur	Construction of 72 nos. T-II accommodation with development work and ancillary service for AR Sector HQ/Bn. HQ at Keithalmanbi at Manipur	NPCCL	30	Completed	1,480.42	1,349.06	-131.36
81.	BSF	Delhi	Providing 20 nos. 320 KVA DG Set, for HQ, CGO Complex, New Delhi	CPWD	26	Completed	86.1	66.54	-19.56
82.	NSG	Delhi	Development of 05 Acre land near IGI Airport, raising of ground, New Delhi	CPWD	33	Completed	100	0.11	-99.89
83.	NSG	Delhi	Temporary Pre-fabricated men barrack (5 nos.) at NSG Samalkha	CPWD	27	Completed	704	569	-135
84.	NSG	Delhi	Up gradation of Electric System in Manesar	CPWD	23	Completed	99.75	55.35	-44.4
85.	NSG	Delhi	RCC Boundary Wall at HQ	CPWD	38	Completed	226	126	-100

86.	NSG	Delhi	Construction of 8 additional class rooms for Montessari School, Manesar, Haryana	CPWD	5	Completed	97.73	82.9	-14.83
87.	BSF	MP	Construction of admn./communication block for Reserve Bn. Campus at Indore (MP)	NBCC	4	Completed	272.96	58.14	-214.82
88.	BSF	MP	Construction of GOs Mess with 07 suites for Bn. HQ at Indore Campus (MP)	NBCC	9	Completed	216.35	77.94	-138.41
89.	BSF	MP	Construction of Type-III (G+2) quarters, 26 nos. for Bn. HQ at Indore Campus (MP)	NBCC	8	Completed	475.81	95.58	-380.23
90.	BSF	U.P.	Construction of store block, tradesman shop & mtrs. Complex for Bn. HQ Campus Baad Mathura	NBCC	0	Completed	492	46	-446
91.	ITBP	Assam	Providing and erection of 04 nos. plastic huts for store and jawans accommodation at Tezpur	DEPTT.	2	Completed	28.02	27.76	-0.26
92.	SSB	Arunachal Pradesh	Constructions of 02 nos. 20 men barrack at Company HQ. Jang under 38th Bn.	DEPTT.	8	Completed	44.62	41.30	-3.32
93.	ITBP	Arunachal Pradesh	Construction of 04 nos. Dining Hall for ATC Lohitpur.	DEPTT.	0	Completed	24.48	24.4	-0.08
94.	ITBP	Arunachal Pradesh	Construction of SOs living accommodation at CLG forward post.	DEPTT.	19	Completed	13.66	9.94	-3.72
95.	CRPF	West Bengal	Construction of Perimeter/Security Wall for Quarter Guard at CRPF, Group Centre, West Bengal	CPWD	8	Completed	28.23	24.45	-3.78
96.	BSF	Tripura	Renovation/Up-gradation of Admn. block of 19 Bn. Campus, Salbagan, Sector HQ, Gokulnagar	DEPTT.	0	Completed	32.82	21.04	-11.78
97.	ITBP	Sikkim	Construction of Jawan Line Including Toilet at Kerang Post of 11th Bn. ITBP	DEPTT.	30	Completed	25.22	24.76	-0.46
98.	CRPF	Maharashtra	359 nos. (T/I-93, II-255, III-7& IV-4 nos.) family quarters ( Construction of 18 nos.Type-I quarters.)	CPWD	28	Completed	1764.32	1416.1	-348.22
99.	CRPF	Delhi	Lying of C.I. Pipeline Nazafgarh	CPWD	6	Completed	833	588	-245
100.	NSG	Delhi	Construction of Indoor Shooting	CPWD	11	Completed	220	177	-43

101.	CRPF	Chhattisgarh	Construction of 6 nos.Semi Permanent Buildings(22 X 8.5 Mtrs) Having AC Sheet Roofing)	CPWD	NA	Completed	98.42	65.06	-33.36
102.	CRPF	MP	Construction of Admn. Block, CRPF Bangrasiya, Bhopal	CPWD	25	Completed	161.92	152.79	-9.13
103.	CRPF	Chhattisgarh	Construction of Combined Admn. block/quarter guard/Store Block at Group Centre, Bilaspur	CPWD	6	Completed	985.62	953.09	-32.53
104.	CRPF	Chhattisgarh	Construction of 50 Bedded Composite Hospital at Group Centre Bilaspur	CPWD	16	Completed	1219.87	751.05	-468.82
105.	CRPF	Chhattisgarh	Construction of Sos Mess/Dormitory at Group Centre Bilaspur	CPWD	5	Completed	635.02	380.25	-254.77
106.	CRPF	MP	Construction of 50 Bedded Hospital at Group Centre,CRPF Bangrasiya Bhoapl	CPWD	0	Completed	1281.41	1062.47	-218.94
107.	CRPF	MP	Construction of Coimbined Building of Admn./ Training Block/ Class Room/ Sand Model Room-Cum-Lecture Hall and 2 nos. 270 men barracks at CIAT Shivpuri	NBCC	27	Completed	4202.75	3587	-615.75
108.	CRPF	MP	Construction of Combined Building of GO's Mess & Suites, SOs Mess & Dormitory Block, Combined Building for Quarter Guard, Store Block, Tradesmen Shop, and Combined Building for Men's Club , Canteen, Grain Godown, Badminton Court and Gymnasium at Central Training College (CTC) Shivpuri, MP	NBCC	25	Completed	4170.84	2274	-1896.8
109.	CISF	Chhattisgarh	Construction of 2 nos. Drill Sheds for Regional training Centre, Bhilai	CPWD	8	Completed	55.11	53.51	-1.6
110.	CISF	Chhattisgarh	Construction of various works for armoury & magazine building at base workshop RTC at Bhilai	CPWD	17	Completed	58.01	57.31	-0.7
111.	CISF	Chhattisgarh	Construction of perimeter wall from SOs ATM Gate to corner RTC Bhilai	CPWD	4	Completed	46.22	38.50	-7.72
112.	CISF	Chhattisgarh	Construction of training block for RTC Bhilai	CPWD	5	Completed	310.00	248.08	-61.92
113.	CISF	Chhattisgarh	Construction of DTS Building RTC Bhilai	CPWD	3	Completed	20.32	16.56	-3.76
114.	CISF	MP	Providing and fixing chain link & concertina coil fencing along choral river bank of old campus, Barwaha	CPWD	0	Completed	28.7	26.2	-2.5

115.	CISF	MP	Essential repair & maintenance of non-residential buildings of , Barwaha	CPWD	0	Completed	15.69	14.92	-0.77
116.	BSF	Gujarat	Construction of 10 bedded hospital with maternity ward for 11 Bn. Campus Gandhidham.	CPWD	23	Completed	98.85	91.92	-6.93
117.	BSF	Rajasthan	Construction of quarter guard building at Campus, Udaipur	CPWD	16	Completed	108.5	93.74	-14.76
118.	BSF	Rajasthan	Construction of MT complex with garage Campus Bhramsar Ramkunda for Bn. HQ Under Sector HQ	CPWD	8	Completed	257	237	-20
119.	BSF	Rajasthan	Construction of provisioning complex for Sector HQ Campus Sam Road	CPWD	12	Completed	195	128	-67
120.	CISF	Rajasthan	Construction of Sewage Treatment Plant for RTC Behror	CPWD	4	Completed	120.75	113.61	-7.14
121.	ITBP	Rajasthan	Providing & Laying Water Supply Line at 42 Bn., Jodhpur	CPWD	6	Completed	64.72	52.89	-11.83
122.	CISF	Rajasthan	Construction of SOs Mess for RTC Behror	CPWD	6	Completed	539.63	472.63	-67
123.	CRPF	Rajasthan	Construction of boundary wall, main gate, guard room, watch towers and security lights at Group Centre-II Ajmer, Rajasthan	CPWD	4	Completed	919.1	870.25	-48.85
124.	CRPF	Gujarat	Construction of women barrack	CPWD	1	Completed	94.65	92.96	-1.69
125.	CRPF	Gujarat	Construction of underground sump & providing & laying water supply line for storage & distribution of Narmada Water	CPWD	4	Completed	98.6	72.05	-26.55
126.	CRPF	Gujarat	Providing& fixing of Sewage Treatment Plant	CPWD	0	Completed	84.31	82.14	-2.17
127.	CRPF	Delhi	Development and bulk services at Kadarpur	CPWD	9	Completed	2502	506	-1996
128.	BSF	Punjab	Construction of boundary wall, Madhopur	CPWD	2	Completed	100	76	-24
129.	CRPF	Delhi	Construction of 699 quarters at Kadarpur Haryana	CPWD	19	Completed	3106	1134	-1972
130.	ITBP	J&K	Construction of SOs Mess and Dormitory	CPWD	3	Completed	496	442	-54
131.	SSB	HP	Construction of bounday wall, Sapri.	CPWD	4	Completed	87	84	-3
132.	SSB	HP	Construction of Indoor Shooting Range at SSB, Shamshi, Kullu	CPWD	14	Completed	273	214	-59
133.	BSF	J&K	Construction of Admn. Block & Communication Block at Ftr. HQ Sri Nagar	JKPCC	4	Completed	1293	125	-1168

134.	CRPF	J&K	Underground water sump lines and providing CGI sheet roofing	CPWD	23	Completed	74.35	72	-2.35
135.	BSF	J&K	Boundary wall with barbed wire fencing at FTR HQ, Baramulla	CPWD	20	Completed	177	87	-90
136.	ITBP	J&K	Renovation of ceiling of Type-I/24 and Type-II/36 nos. quarters at Leh	Deptt.	5	Completed	27	24	-3
137.	ITBP	J&K	Up gradation of Children Park near family quarters at 15th Bn. ITBP Leh	Deptt.	7	Completed	18	17	-1
138.	CRPF	J&K	Construction of open surface drain along the boundary wall for CRPF Campus Nagrota	CPWD	2	Completed	22	15	-7
139.	CRPF	J&K	Construction of 60 nos. family quarters (T/Iii-22, T/Iv-24,T/V-12)	CPWD	NA	Completed	1633	1123	-510
140.	CRPF	Haryana	Carrying out development and bulk services (civil & electrical ) works at Group Centre Sonipat, Haryana	NBCC	20	Completed	2509	1635	-874
141.	CISF	Tamil Nadu	Construction of Quarter Guard at 4th Reserve Bn. Sivagangai	NBCC	12	Completed	238.67	187.56	-51.11
142.	CISF	U.P.	Construction of boundary wall with coil fencing at Kalindipuram Allahabad	CPWD	0	Completed	45	34	-11
143.	CRPF	Tamil Nadu	Providing bulk services and development works	CPWD	NA	Completed	475.41	437.92	-37.49
144.	CRPF	U.P.	Construction of 121 nos. BOAC at Allahabad.	CPWD	15	Completed	29	24	-5
145.	CRPF	U.P.	Renovation of 40 nos. toilets at CRPF campus, Allahabad.	CPWD	11	Completed	46	44	-2
146.	CRPF	Tamil Nadu	Construction of Firing Range	CPWD	9	Completed	160.23	104.95	-55.28
147.	CRPF	U.P.	Renovation of street light, park light Allahabad	CPWD	5	Completed	30	26	-4
148.	CRPF	Telangana	Construction of 2 nos.180 men barracks , CRPF	CPWD	1	Completed	523.00	442.00	-81
149.	SSB	U.P.	Construction of permanent building at development works Bankati Under 39th Bn. Palia	Deptt.	18	Completed	58	56	-2
150.	BSF	Bihar	Construction of 10 nos. additional suits for Combined Officers Mess at Campus	CPWD	10	Completed	150	136	-14

151.	BSF	Uttarakhand	Construction of others accommodation (G-1) Campus Markham Grant-II Dehradun	CPWD	5	Completed	29	24	-5
152.	ITBP	Jharkhand	Construction of administrative block for Signal Training Centre, Hazaribagh	CPWD	15	Completed	498.58	315.24	-183.34
153.	BSF	U.P.	Construction of 90 men barrack at Sector HQ, Greater Noida	NBCC	10	Completed	475	126	-349
154.	ITBP	Uttarakhand	Construction of residential cum office Complex at Mana	CPWD	23	Completed	149	85	-64
155.	ITBP	Uttarakhand	Construction of 8 nos.T-II (Double Storied) quarters. at Gothi	CPWD	4	Completed	89.00	83	-6
156.	ITBP	Uttarakhand	Construction of GOs Mess at Munsyari	CPWD	5	Completed	77.00	66	-11
157.	ITBP	Uttarakhand	Providing fencing around the camp at upper Rimkhim and lower Limkhim Lathal and Sanchutalla post	Deptt.	0	Completed	54	52	-2
158.	ITBP	Uttarakhand	Construction of GOs accommodation at Gastoli Post at 8th Bn. Gaucher	Deptt.	0	Completed	25	22	-3
159.	ITBP	Uttarakhand	Construction of Quarter Master Store at 36th Bn. Lohaghat	CPWD	40	Completed	401.00	211	-190
160.	ITBP	Jharkhand	Construction of SOs Mess at Ranchi, Jharkhand,40th Bn.	CPWD	2	Completed	223.43	178.58	-44.85
161.	ITBP	Jharkhand	Construction of bituminous road and drain for non-residential buildings at 40th Bn., ITBP Ranchi	CPWD	0	Completed	2493.59	304.12	-2189.5
162.	SSB	Bihar	Construction of Boundary Wall at Bathnaha, Araria (Bihar).	CPWD	2	Completed	456.35	393	-63.35
163.	SSB	Bihar	Construction of development works, building at Company HQ. cum development works at Sikta under Bn. HQ. SSB, Narkatiaganj	CPWD	8	Completed	444.76	290	-154.76
164.	CRPF	Telangana	Construction of 248 nos. family quarters (Type II - 240 nos. and Type III 8 nos.) for Group Centre. Jawahar Nagar, Hyderabad.	CPWD	6	Completed	1445.00	955.00	-490
165.	SSB	Bihar	Construction of boundary wall for Sector HQ, SSB, Muzaffarpur.	CPWD	NA	Completed	238.33	191	-47.33



166.	SSB	Bihar	Construction of building at Company HQ. and development works at Pantoka under Bn. HQ. SSB, Piprakothi, Distt. East Champaran.	CPWD	NA	Completed	444.14	339	-105.14
167.	SSB	Bihar	Construction of 128 Men Barrack at SSB Bn. HQ, Bathnaha, Distt. Araria (Bihar).	CPWD	22	Completed	476.93	426	-50.93
168.	CRPF	Bihar	Construction of 4 nos. 180 men barracks Group Centre, Muzaffarpur, Bihar.	CPWD	NA	Completed	1346.66	426	-920.66
169.	CRPF	Jharkhand	Construction of Electrical Sub Station for 209 , Cobra Bn., Kunti	CPWD	NA	Completed	90.68	55.67	-35.01
170.	CRPF	Jharkhand	Construction of BIN Type Magazine for GC, CRPF, Sambo, Ranchi	CPWD	NA	Completed	33.53	19.1	-14.43
171.	SSB	U.P.	Construction of 10 Bedded Hospital at Palia.	CPWD	4	Completed	425	388	-37
172.	SSB	Uttarakhand	Construction of permanent infrastructure including development of site and rain water harvesting at development works-Bagrihat	CPWD	0	Completed	222.00	54	-168
173.	ITBP	Jharkhand	Providing & fixing of 4 nos. pre-fabricated huts of size 19.52 mx6.1 m including 1.525 m veranda & attached 5 nos. water closet (WC) and 4 nos. bath for each hut for ITBP, Ranchi SH: Preparation of Base and flooring for pre- fabricated huts.	CPWD	NA	Completed	52.32	48.74	-3.58
174.	CRPF	Uttarakhand	Construction of Admn. Building	NBCC	15	Completed	2403.00	1827	-576
175.	CRPF	Uttarakhand	Construction of carrying out development & bulk services	NBCC	6	Completed	3128.00	1570	-1558
176.	ITBP	Jharkhand	Construction of 97 nos. family quarters (T/II-96,T/V-01)(external electrification work from sub-station to family quarters and installation of tube well	NBCC	10	Completed	683.7	681.62	-2.08
177.	CRPF	U.P.	Construction of 20 Bedded Hospital	CPWD	31	Completed	368	275	-93
178.	CRPF	U.P.	Construction of MT Garage and Workshop Lucknow	CPWD	0	Completed	306	212	-94
179.	CRPF	U.P.	Construction of office of DIGP Group Centre Lucknow	CPWD	12	Completed	145	128	-17
180.	ITBP	U.P.	Construction of boundary wall, road, sentry post including front gate & front wall and dormitory block with attached toilet at Greater Noida.	CPWD	7	Completed	582	522	-60

181.	SSB	Bihar	Construction of 10 bedded hospital at 12th Battalion HQ, Bagha, Valmiki Nagar, Bihar.	CPWD	29	Completed	540.38	251	-289.38
182.	SSB	Bihar	Development of site & bulk services for SSB at Narkatiaganj. SH: Civil Works.	CPWD	NA	Completed	1585.9	710	-875.9
183.	ITBP	Uttarakhand	Construction of 10 Bedded Hospital at Mirthi	CPWD	14	Completed	179.00	134	-45
184.	ITBP	Uttarakhand	Construction of quarter guard, quarter master (QM) store and MI Room at Auli	CPWD	20	Completed	401	340	-61
185.	BSF	Karnataka	Construction of 10 Numbers semi-permanent structures for residential and non-residential accommodation for 82nd Battalion, at Karahalli	Deptt.	0	Completed	59.99	58.06	-1.93
186.	BSF	Karnataka	Upgradation of existing Type I staff quarters (120 numbers) at Signal Training Centre, Bengaluru	Deptt.	1	Completed	58.36	32.94	-25.42
187.	CRPF	Telangana	Providing exhaust fans in kitchen of 972 nos. family quarters (285 nos. Type-I, 653 nos. Type-II, 34 nos. Type-III) including point wiring at CRPF, Jawahar Nagar	CPWD	6	Completed	44.82	24.52	-20.3
188.	CISF	Telangana	Construction of 200 Bedded Semi Permanent Barracks for Trainees at NISA	CPWD	3	Completed	29.63	19.11	-10.50
189.	CRPF	Punjab	Construction of Compounding Wallat Hira Nagar	CPWD	4	Completed	63.98	57	-6.98
<b>Total</b>							<b>76682.86</b>	<b>47775</b>	<b>28907.86</b>
1.	SSB	Delhi	Renovation of Quarter Guard at Ghitorni, New Delhi	Deptt.	2	Not Completed	59.51	Not available	Not available
2.	AR	Tripura	Construction of 08 nos. single JCOs accommodation (G+I) 02 blocks of 06 nos. single men barrack (G+II) one no. Admn. Block 01 no. Officers Mess one no. JCO Club and internal road for 36 AR at Radhanagar	NPCCCL	43	Completed	755.85	-do-	-do-
3.	AR	Tripura	Construction of 02 nos. T-V (G+I) 02 nos. T-IV (G+I) 12 nos. T-III 90 nos. T-II (G+II) and 06 nos. single Officer accommodation for 36 AR at Radhanagar	NPCCCL	27	Completed	1,196.11	-do-	-do-
4.	AR	Tripura	Construction of 06 nos. T-III (G+II) & 78 nos. T-II (G+II) for 15 AR at Teliamura, Tripura	NPCCCL	41	Completed	854.31	-do-	-do-

5.	AR	Nagaland	Construction of 01 nos. Type-IV quarters (GF), 06 nos. Type- III quarters. (G+II) and 06 nos. single Officers living accommodation. (G+I)	NPCCL	16	Ongoing	658.65	-do-	-do-
6.	CISF	Delhi	Reception-cum Registration Counter from the Gallery Nursing Staion to X Ray Room at Saket	CPWD	14	Completed	3.41	-do-	-do-
7.	BSF	West Bengal	Construction of Office Block, Magazine, Kote Wireless Block, & Jawan Barrack at border out post Devipur of 57 Bn. under Sector HQ Malda, Malda Ftr .	CPWD	9	Completed	105.13	-do-	-do-
8.	BSF	Gujarat	Construction of 04 nos. Pre-fab structures for jawan barrack and development works near Villkosa of 157 Bn. (Marrine Bn.) under Sector HQ Bhuj	Deptt.	15	Not completed	30.57	-do-	-do-
9.	SSB	Assam	Construction of River Training Work, Retaining Wall and Boundary Wall On Northern Side of SSB Campus Bongaigaon, Assam	CPWD	1	Completed	118.13	-do-	-do-
10.	SSB	Assam	Construction of Quarter Guard Including development of site at Bn. HQ SSB Kokrajhar	CPWD	5	Completed	187.14	-do-	-do-
11.	SSB	Assam	Construction of 10 bedded Hospital including development of site for Bn. HQ at Kajalgaon, Assam	CPWD	15	Ongoing	373.43	-do-	-do-
12.	SSB	Assam	Construction of GO's Mess With Six nos. Suits for Bn. HQ SSB Kajalgaon, Assam	CPWD	1	Ongoing	187.29	-do-	-do-
13.	AR	Manipur	Construction of residential building boundary wall around Mantripukhri Garrison at Mantripukhri, Manipur	NPCCL	18	Completed	498.00	-do-	-do-
14.	AR	Manipur	Construction of 12 nos. Type-II (G+II) in 2 block and 10 nos. Type-IV(G+1) In 5 blocks with allied services and development works for Assam Rifles at Mantripukhri (Manipur)	NPCCL	35	WIP	493.67	-do-	-do-
15.	AR	Manipur	Construction of one block of 03 nos. single men barracks (G+II) with approach road for new location of Assam Rifles at Phunderi (Manipur)	NPCCL	35	Completed	427.25	-do-	-do-
16.	AR	Manipur	Construction of security wall including main gate, sentry posts, security lights for residential accommodation for AR Bn. at Modi (Manipur)	NPCCL	33	Ongoing	450.06	-do-	-do-

17.	AR	Manipur	Construction of administrative block (g+1) including allied services and development works for Assam Rifles at Phundrei (Manipur)	NPCCL	35	Ongoing	461.51	-do-	-do-
18.	AR	Manipur	Construction of quarter guard, kote, armory and arm shop including development works and internal road for Assam Rifles Bn. at Modi(Manipur)	NPCCL	33	Ongoing	245.42	-do-	-do-
19.	AR	Assam	Construction of 01 No Type-VI (G+I) in one block with allied services and development works for HQ IGAR (East) at Srikona (Assam)	NPCCL	1	Completed	80.32	-do-	-do-
20.	AR	Manipur	Construction of 04 nos. single officers accommodation (G+I) in 1 block with allied services and development works for AR Bn. at Mantripukhri, Manipur	NPCCL	2	Ongoing	85.29	-do-	-do-
21.	AR	Nagaland	Construction of 08 nos. single JCOs accommodation (G+III) in one block with allied services and development works for AR BN at Chieswama	NPCCL	18	Ongoing	106.35	-do-	-do-
22.	AR	Nagaland	Construction of 08 nos. single JCOs( G+III) In one block including development works and allied services for Sector HQ AR at Tuensang, Nagaland	NPCCL	12	Completed	112.30	-do-	-do-
23.	AR	Manipur	Construction of 01 No single men barrack (G) in 01 block with allied services and development works for HQ 10 Ssect AR at Somsai (Manipur)	NPCCL	25	Completed	119.34	-do-	-do-
24.	AR	Manipur	Construction of 02 nos. Type-V quarters (G) In 1 block including development works and allied services for 4 works AR at Keithalmanbi, Manipur	NPCCL	34	Completed	128.22	-do-	-do-
25.	AR	Assam	Construction of 08 nos. single officer (G+III) in one block and 07 nos. single civilian accommodations (G+III) in one block including development works and allied services for AR Bn. at Srikona (Assam)	NPCCL	26	Completed	261.00	-do-	-do-
26.	AR	Manipur	Construction of 24 nos. single JCOs accommodation (G+III) in 3 block with allied services and development works for AR Bn. at Kangvai (Manipur)	NPCCL	17	Completed	340.20	-do-	-do-
27.	AR	Manipur	Construction of Housing Project- 24 nos. Type-II quarters. (G+III) In 03 blocks with allied services and development works for AR Bn. at Phundrei (Manipur)	NPCCL	15	Ongoing	462.04	-do-	-do-

28.	AR	Manipur	Construction of recreation room (g) in 1 block with allied services and development works for AR Bn. at Lmoreh (Manipur)	NPCCL	10	Completed	96.57	-do-	-do-
29.	AR	Manipur	Construction of quarter guard, Kote, Armourer Shop (G) in 1 block with allied services and development works for AR Bn. Kangvai Manipur.	NPCCL	12	Ongoing	232.03	-do-	-do-
30.	AR	Manipur	Construction of 01 office building (G+I) in one block with allied services and development works for HQ IGAR (S) AR at Mantripukhri, Manipur.	NPCCL	12	Ongoing	260.04	-do-	-do-
31.	SSB	Assam	Construction of Residential Quarters at Sector HQ Rangia.	CPWD	10	Completed	566.64	-do-	-do-
32.	SSB	Arunachal Pradesh	Construction of infrastructure (45 nos. Type-II quarters) at 38th Bn. SSB Tawang Under FTR Guwahati.	CPWD	16	Ongoing	770.00	-do-	-do-
33.	SSB	Assam	Construction of Administrative Block at Sector HQ Rangia.	CPWD	15	Ongoing	533.53	-do-	-do-
34.	BSF	Delhi	Construction of 120 men barrack at Signal Training School Tigri, New Delhi	NBCC	31	Completed	484.29	-do-	-do-
35.	BSF	Delhi	Construction of Type-III (14 nos.) and Type-IV (05) at STS Tigri	NBCC	32	Completed	415.73	-do-	-do-
36.	NSG	Delhi	Construction of Special Operation Training Centre Building at Manesar	CPWD	15	Ongoing	0.97	-do-	-do-
37.	BSF	MP	Construction of 34 Type-II (34 nos.) quarters for CSWT at Indore	NBCC	9	Completed	461.01	-do-	-do-
38.	BSF	MP	Construction of 120 men barrack for Sector HQ Bhopal	NBCC	9	Completed	470.19	-do-	-do-
39.	BSF	Meghalaya	Construction of Type-II (04 nos.) Quarters (Double Storied) at Campus Umpling	Deptt.	15	Completed	48.02	-do-	-do-
40.	ITBP	Arunachal Pradesh	Construction of 04 nos. CGI Sheet Shed In Patrol Route of Lungar Sub Sector.	Deptt.	5	Ongoing	36.40	-do-	-do-
41.	BSF	MP	Construction of one number 180 men barrack for at CSMT Tekanpur Campus (MP)	NBCC	11	Completed	599.32	-do-	-do-
42.	CRPF	Chhattisgarh	Construction of Admn. Block Buildings at 201 and 204 Cobra Bn. , Jagdalpur	NBCC	50	Completed	735.13	-do-	-do-

43.	BSF	MP	Construction of 120 nos. accommodation at Bijasan under CSWT Indore	CPWD	9	Incomplete	482.33	502.47	20.14
44.	CRPF	Chhattisgarh	Carrying out civil and electrical development and bulk services for 201 & 204 Cobra Bn. s. of CRPF at Jagdalpur	NBCC	12	Incomplete	1721.28	-do-	-do-
45.	BSF	Rajasthan	Construction of residential quarter (SH: 32 nos. Type-II, 16 nos. Type-III, 07 Numbers Type-IV & 02 nos. Type-V) for Bn. Hqr Campus at Alwar (Rajasthan)	CPWD	12	Completed	736.3	-do-	-do-
46.	CISF	Gujarat	Construction of residential and non-residential buildings for GP.HQ Ahmedabad	NBCC	6	Completed	1576.6	-do-	-do-
47.	BSF	Maharashtra	Construction of 11 nos. semi-permanent structure at Signal Training Centre (STC) Chakur	Deptt.	14	Ongoing	35.86	-do-	-do-
48.	BSF	Maharashtra	Construction of basic infrastructure for additional toilet block, bathing point, RO Plant CLP & deep tube well at STC Chakur	Deptt.	17	Ongoing	55.61	-do-	-do-
49.	BSF	Maharashtra	Construction of 08 nos. Semi-Permanent Structures for Additional at STC Chakur	Deptt.	20	Ongoing	54.99	-do-	-do-
50.	CRPF	Maharashtra	Repair and carpeting to the internal road including dressing shoulder and providing masonry storm water drainage wherever required at 102 Bn., RAF Taloja, Navi-Mumbai	CPWD	9	Completed	59.74	-do-	-do-
51.	BSF	Haryana	Construction of 10 bedded hospital With Maternity Ward for Bn. HQ, Bhondsi	CPWD	14	A&ES Cancelled		-	-
52.	BSF	U.P.	Construction of Magazine Building for Bn. Hqr. Mathura	Deptt.	5	Completed	60	-do-	-do-
53.	CISF	U.P.	Construction of Main Gate at Kalindipuram Allahabad	CPWD	5	Completed	15	-do-	-do-
54.	ITBP	Uttra Khand	Construction of Jawan Barrack at Jagrao Post at 8th Bn. Gaucher	Deptt.	8	Completed	30	-do-	-do-
55.	CRPF	Bihar	Construction of Admn. Block, Group Centre, Muzaffarpur, Bihar	CPWD	4	Incomplete	161.08	-do-	-do-
56.	CRPF	Kerala	Construction of room for interactive arms training at CRPF Peringome, Kannur	CPWD	8	Not vailable	Not vailable	-do-	-do-

57.	CRPF	Kerala	Providing peripheral lights, street lights power supply to the new open well & providing submersible pump set, internal electrical lines and installation of 4 nos. watch towers at Regional Training Centre (RTC) Peringome, Kerala	CPWD	2	Not available	Not available	-do-	-do-
58.	CRPF	Telangana	Upgradation of Main office building including DIGP Range office building at Group Centre, CRPF, Hyderabad	CPWD	3	Completed	42.69	-do-	-do-
59.	CRPF	Telangana	Repair/replacement of main sewer line in non-residential area and some place at residential area of CRPF Campus, Hyderabad	CPWD	5	Completed	44.33	-do-	-do-
60.	CISF	Telangana	Repairing & raising the height of boundary wall, fixing of concertina coil etc. from gate no.2 to m.t. section of NISA-, Hakimpet, Hyderabad.	CPWD	3	Completed	46.24	-do-	-do-
61.	CISF	Telangana	Extension of viewers gallery ( on either side) at ceremonial parade ground of NISA - at Hakimpet	CPWD	1	Completed	37.17	-do-	-do-
62.	AR	Manipur	Construction of boundary wall with RCC Posts and 1.35 km new road for Assam Rifles Bn. at Khuga, Manipur	HPL	52	Completed	492.23	-do-	-do-
63.	SSB	Maharashtra	Construction of infrastructure at Reserve Battalion HQ SSB Yelki, Maharashtra	NBCC	22	Completed	5369	-do-	-do-
64.	CRPF	Maharashtra	Construction of 38 nos. family quarters (T/I-4, II-12, III-IV-12 & V-2)	CPWD	0	Completed	335	-do-	-do-
65.	CRPF	Maharashtra	Construction of 399 nos. Type-I 60 nos. quarters	CPWD	7	Completed	1838.34	-do-	-do-
66.	CRPF	Maharashtra	Construction of 2 nos. filter bed and clear water RCC Storage Tank of 2.50 lakh liter capacity	CPWD	6	Completed	98.89	-do-	-do-
67.	CISF	MP	Re-carpeting of roads in residential area, Barwaha	CPWD	8	Completed	27.02	-do-	-do-
68.	BSF	Punjab	Construction of Barracks at Dera Baba Nanak, Punjab	CPWD	0	Completed	388	-do-	-do-
69.	BSF	HP	Construction of Gazetted Officers Mess at campus, Kangra	CPWD	9	Completed	189	-do-	-do-
70.	BSF	Haryana	Construction of Drill Shed at Bn. HQ 33 Bn. , Hisar	Deptt.	5	Completed	60	-do-	-do-
71.	ITBP	Haryana	Construction of Store Depot at Sabili, Haryana	CPWD	30	Completed	62	-do-	-do-

72.	ITBP	Haryana	Providing air conditioners in training block, Millennium Building	CPWD	3	Completed	102	-do-	-do-
73.	BSF	Haryana	Construction of 01 No 120 men barrack including information & recreation centre for Reserve Bn. Campus Bhondsi	NBCC	11	Completed	500	-do-	-do-
74.	BSF	Haryana	Construction of 01 No 120 men barrack including information & recreation centre for Reserve Bn. Campus Bhondsi	NBCC	7	Completed	500	-do-	-do-
75.	CRPF	Tamil Nadu	Construction of 180 men barrack	CPWD	NA	Completed	964.75	-do-	-do-
76.	ITBP	Odisha	Construction of internal road and storm water drainage at 41st Bn., Bhubaneshwar	CPWD	0	Completed	492	-do-	-do-
77.	BSF	Telangana	Construction of 2 nos. 120 men barracks	CPWD	16	Completed	708	-do-	-do-
78.	CRPF	Odisha	Construction of 20 Bedded Hospital for 202 Cobra Bn., Koraput	CPWD	NA	Completed	500	-do-	-do-
79.	CRPF	Odisha	Upgradation of 40 To 50 Bedded Hospital at Group Centre Bhubaneshwar	CPWD	0	Completed	762	-do-	-do-
80.	CRPF	Odisha	Construction of Admn Block/ Quarter Guard/ Store Block/ Tradesmen Shop for 202 Cobra Bn., Koraput	CPWD	0	Completed	992	-do-	-do-
81.	BSF	U.P.	External development works & bulk services (road work/boundary wall/entrance gateway & dormitory block) for Camapus Mathura	NBCC	16	Completed	457	-do-	-do-
82.	CISF	Odisha	Construction of 5 quarters, (Type-V 01 and Type-IV 04) for Regional Training Centre (RTC), Odisha	CPWD	30	Completed	70.73	-do-	-do-
83.	CISF	Odisha	Widening of Firing Range of RTC Odisha	CPWD	31	Completed	71.19	-do-	-do-
84.	ITBP	Jharkhand	Providing & installation of substation equipment, 125 KVA, DG Set and laying 11 KV Hot line for 40th Bn. Ranchi	CPWD	33	Completed	273	-do-	-do-
85.	CRPF	Telangana	Construction of 312 nos. family quarters	CPWD	14	Completed	1947	-do-	-do-
86.	CRPF	Jharkhand	Construction of 3 nos. 240 men barrack for 203, Cobra Bn. Barhi, Hazaribagh	CPWD	10	Completed	2002	-do-	-do-
87.	CRPF	U.P.	Development & bulk services (civil works only) at CRPF campus, Meerut	CPWD	4	Completed	569	-do-	-do-



**Annex-4.14**  
**Cost overrun in ongoing work**  
**(Refer para 4.5.5.1)**

(₹ in lakh)

S. No.	force	State	Particulars of The Work	Executing Agency	Present status	Amount of the AA & ES	Final Exp/Up to date Exp.	Difference with
1.	BSF	Rajasthan	Construction of Administration Block and development works at Nalka of 194 Bn. under Sector HQ Jaiselmair (S)	Departmental	work in progress	39.67	51.32	11.65
2.	BSF	Meghalaya	Construction of combined amenity/community centre for Sector HQ, Dumpling Shillong	CPWD	work in progress	234.90	262.00	27.1
3.	SSB	Arunachal Pradesh	Construction of T-III/8 nos. quarters at 34th Bn. Dirang	CPWD	work in progress	155.79	187.78	31.99
4.	AR	Assam	Construction of security wall In 1.7 Km length with 02 nos. main entry gate and other related development work at new AR KLP at Guwahati	UPJN	work in progress	435.44	435.61	0.17
5.	BSF	West Bengal	Construction of boundary wall (length- 7300 metre) along the periphery of training Centre, in West Bengal Signal	CPWD	work in progress	521.15	690.82	169.67
6.	CISF	Assam	Construction of non-residential accommodation for Group HQ Guwahati	CPWD	work in progress	1,095.17	1,208.00	112.83
7.	CRPF	Assam	Construction of boundary wall, main gate, guard room, sentry post & watch tower at Group Centre, Silchar	CPWD	work in progress	299.00	902.30	603.3
8.	AR	Nagaland	Construction of 12 nos. Type-III in (G+II) and 12 nos. Type-II quarters. (G+II) for 5 Sector HQ and 78 nos. Type-II quarters. (G+II) for Assam Rifles Bn. at Chieswema, Nagaland	NPCCL	work in progress	1,028.02	1,188.74	160.72

9.	AR	Manipur	Construction of 06 nos. single Jcos Living Accommodation (G+I), 01 Block of 03 nos. single Men Barrack (G+II), 01 No Administrative Block (G+I) and 01 no. Officers Mess for Sector HQ and 01 block of 03 nos. single men barrack (G+I) for Assam Rifles Bn. at Keithalmanbi (Manipur)	NPCCL	work in progress	1,336.39	1,377.37	40.98
10.	AR	Manipur	Construction of 01 no. T-VI (GF) 04 nos. T-V(G+1), 13 nos. T-III, 18 nos. T-II (G+2) and 02 nos. officers accommodation for AR Sector HQ at Keithalmanbi	NPCCL	work in progress	1,008.46	1,019.92	11.46
11.	AR	Manipur	Construction of 48 nos. Type-II (G+II) In 08 block and 07 nos. single JCOs accommodation with development works, water supply and external electrification for Assam Rifles at Jwalamukhi (Manipur)	NPCCL	work in progress	1,207.16	6,511.32	5304.16
12.	CISF	Delhi	Construction of 108 Residential quarters at SSG Greater Noida	NBCC	work in progress	1534.96	1619.54	84.58
13.	CISF	MP	Renovation of Darya Mahal of Regional Training Centre (RTC), Barwaha	CPWD	work in progress	290	308.4	18.4
14.	CISF	MP	Construction of inspection gallery and stage in existing miniature firing for RTC	CPWD	work in progress	60.37	63.11	2.74
15.	AR	Delhi	Construction of 32 nos. Type-II, 16 nos. Type-III quarters and hostel for 30 boys and 20 girls for Assam Rifles at Dwarka, New Delhi	EPIL	work in progress	481	1360	879
16.	BSF	Rajasthan	Construction of Hanuman Ki Khejari Firing Range at Campus, 192 Bn.	CPWD	work in progress	152.14	161.75	9.61
17.	CISF	Rajasthan	Construction of MT Garage for RTC, Behror, Rajasthan	CPWD	work in progress	79.6	90.69	11.09
18.	CISF	Rajasthan	Construction of 05 No. S residential quarters (T-V 1, T-IV 4) for RTC at RTC Deoli	CPWD	work in progress	48.54	71.63	23.09
19.	BSF	Punjab	Construction of boundary wall at Campus 143 Bn. Kmswala, Punjab	CPWD	work in progress	309	495	186
20.	ITBP	J&K	Construction of MT Workshop at Leh	CPWD	work in progress	194	290	96

21.	ITBP	Haryana	Construction of Sewerage Treatment Plant at Saboli, Haryana	CPWD	work in progress	71.82	81.82	10
22.	ITBP	Haryana	Construction of GOs Mess at Bn. HQ at Bhanu	CPWD	work in progress	69	118.68	49.68
23.	CRPF	Delhi	Construction of admn. & Training block at Group Centre, Kadarapur	CPWD	work in progress	1,100	1526	426
24.	BSF	U.P.	Construction of perimeter fencing of Campus Baad Mathura	Departmental	work in progress	33	60	27
25.	CISF	TN	Providing fly proof shutters for the residential quarters (53 nos. of Type-I & 160 No. S of Type-II )for RTC (A)	CPWD	work in progress	37.58	80.78	43.2
26.	ITBP	Uttarakhand	Construction of admn. block for 1 <sup>st</sup> Bn.	CPWD	work in progress	293	314	21
27.	ITBP	Uttarakhand	Construction of chain link fencing in remaining area of 30 <sup>th</sup> Bn. HQ	CPWD	work in progress	142	182	40
28.	ITBP	Uttarakhand	Water Supply and Drainage System Jalagam Parisar at Gaucher	CPWD	work in progress	85	89	4
29.	ITBP	Uttarakhand	Construction of Officer Mess at Auli	CPWD	work in progress	136	206	70
30.	CRPF	Telangana	Construction of Sewage Treatment Plant, laying of CI Pipe Line Grid for horticulture purpose	CPWD	work in progress	44.33	50.61	6.28
31.	CRPF	Jharkhand	Construction of Electrical Substation for 203, Cobra Bn. , Barhi, Hazaribagh	CPWD	work in progress	36.58	37.29	0.71
32.	BSF	MP	Construction of 120 nos. accommodation at Bijasan under CSWT Indore	CPWD	work in progress	482.33	502.47	20.14
<b>Total</b>						<b>13041.40</b>	<b>21543.95</b>	<b>8502.55</b>

## Annex-4.15

**Other Irregularities-Commencement of Work without Work Order /Agreement for AR  
(Refer para 4.6.1)**

(₹ in lakh)

S.No.	Name of Work	Name of the Agency	Name of the force	Payment made before award of Work
1.	Construction of 18 nos. Type-II quarters (G+II) in 3 blocks for Assam Rifles at Jorhat (Assam).	NPCCL	Assam Rifles	148.23
2.	Construction of 12 nos. Type-II quarters (G+II) in 2 blocks and 12 nos. Type-III (G+II) in 02 blocks with allied services and development works for Assam Rifles at Jorhat (Assam).	NPCCL	Assam Rifles	20.11
3.	Constructions of 01 block of 04 nos. single men barrack, 01 no. JCO Mess and 01 nos. 20 bedded Hospital for Assam Rifles Battalion at Haflong (Assam).	NPCCL	Assam Rifles	124.26
4.	Construction of 01 block of 04 nos. single men barrack (G+III) and Bituminous Road for Assam Rifles Bn. at Srikona Silchar.	NPCCL	Assam Rifles	46.58
5.	Construction of 01 block of 03 nos. single men barrack (G+II) and 01 block of 06 nos. Type -II (G+II) for No 2 Transit Camp at Jorhat (Assam).	NPCCL	Assam Rifles	0
6.	Construction of 12 nos. Type -II (G+II) in 02 blocks with allied services and development works for Assam Rifles Bn. at Jorhat (Assam).	NPCCL	Assam Rifles	1.67
7.	Construction of 06 nos. Type -II (G+II) in 01 blocks and 02 nos. Type-II (G) in 01 block with allied services and development works for Assam Rifles Bn. at Jorhat (Assam).	NPCCL	Assam Rifles	0
8.	Construction of 02 nos. Type-V (G+1) with allied services and development works for Assam Rifles at Haflong (Assam).	NPCCL	Assam Rifles	0
9.	Construction of 08 nos. single officer (G+III) in one Block for AR Bn. at Srikona (Assam).	NPCCL	Assam Rifles	0
10.	Construction of single Civilian Accommodation (G+III) in one Block including development works and allied services for AR Bn. at Srikona (Assam).	NPCCL	Assam Rifles	0
11.	Construction of MT accommodation in 03 blocks including allied services and development works for AR Bn. at Haflong (Assam).	NPCCL	Assam Rifles	0
12.	Construction of Regimental School (G+I) in 01 block with allied services and development works for AR Bn. at Lokhra (Assam).	NPCCL	Assam Rifles	0

13.	Construction of quarter guard, Kote, armorer shop (G) in one block with allied services and development Works for AR Bn. at Haflong (Assam).	NPCCL	Assam Rifles	0
14.	Construction of 06 nos. Type-V qtrs (G+II) in one block with allied services and development works for IGAR (East) at Srikona (Assam).	NPCCL	Assam Rifles	0
15.	Construction of 01 No Type-VI (G+I) in one block with allied services and development works for HQ IGAR (East) at Srikona (Assam).	NPCCL	Assam Rifles	0
16.	Construction of 11 nos. single JCO's accommodations (G+II) in 02 block with allied services and development Works for 3 MGAR at Jorhat (Assam).	NPCCL	Assam Rifles	0
17.	Construction of 01 No single men barrack (G) in 01 block with allied services and development works at Jorhat (Assam).	NPCCL	Assam Rifles	0
18.	Construction of Regimental School (GH+I) in 1 block with allied services and development works for AR Bn. at Haflong (Assam).	NPCCL	Assam Rifles	0
19.	Construction of storage accommodation (G) in 1 block including development works and allied services for AR at Jorhat (Assam).	NPCCL	Assam Rifles	0
20.	Construction of 02 nos. Type-V quarters (G) in 1 block with allied services and development works for HQ 25 Sector AR at Jorhat (Assam).	NPCCL	Assam Rifles	0
21.	Construction of 2 nos. Type-V quarters, 4 nos. single JCO accommodation and 16 nos. Type-II quarters for AR, Udaipur and Tripura.	NPCCL	Assam Rifles	0
22.	Construction of 2 nos. Type-V quarters, 2 Type-IV, 12 nos. Type-III, 90 nos. Type-II, 6 nos. single officers accommodation for AR, Radhanagar, Tripura.	NPCCL	Assam Rifles	233.74
23.	Construction of 16 nos. Type-II, quarters at Agartala, Tripura.	NPCCL	Assam Rifles	108.77
24.	Construction of 8 nos. single JCO accommodation, 6 nos. single men barrack, 1 no. administration block, 1 no. officers mess and 1 no. JCO club for AR Radhanagar, Tripura.	NPCCL	Assam Rifles	81.48
25.	Construction of boundary wall for AR at Teliamura, Tripura.	NPCCL	Assam Rifles	73.64
<b>Total</b>				<b>889.06</b>

**Annex- 4.16**  
**Other Irregularities-Commencement of Work without Work Order /Agreement for BSF**  
**(Refer para 4.6.1)**

(₹ in lakh)

S.No.	Name of Work	A.A./E.S	Date of Work order issued to contractor	Date of agreement	Date of MOU signed between the client and NBCC
1.	Constructions of 01 no. 180 men barrack for at CSMT Tekanpur Campus (MP).	599.32	04.03.2014	23.04.2014	17.04.2014
2.	Construction of Administration/Communication block for Reserve Bn. Campus at Indore.	272.96	15.06.2013	04.07.2013	04.07.2013
3.	Construction of GOs Mess with 07 suites for Bn. HQ at Indore.	216.35	15.06.2013	04.07.2013	04.07.2013
4.	Construction of Type-III (G+2) Residences, 26 nos. for Bn. HQ at Indore Campus (MP).	475.81	15.06.2013	04.07.2013	04.07.2013
5.	Construction of Type-IV & Type-V for Bn. HQ at Indore Campus (MP)	287.64	15.06.2013	04.07.2013	04.07.2013
6.	Construction of Type-II 34 nos. quarter at CSWT Indore.	461.01	20.12.2013	11.02.2014	17.04.2014
7.	Construction of 120 Men Barrack for Sector HQ Bhopal.	470.19	17.07.2014	NA	MoU between client department and NBCC was not signed till date of audit.
8.	Construction of single SOs accommodation with prefabricated (G+1) modular structure for Bn. Headquarter at Doiwala, Dehradun (Uttarakhand).	25.00	12.06.2013	Executed without agreement	No Agreement signed
9.	Quarter Type-III (14 nos.) and Type-IV (05) of at Signal Training School Tigiri, New Delhi.	415.73	Aug-2014	Nov.2014	Nov.2014

**Annex-6.1**  
**Water used was not tested/Non-maintenance of Quality Assurance records**  
**(Refer para 6.1.3 & 6.1.4)**

(₹ in lakh)

Sl. No.	Name of the work	Name of Force	Executive Agency	Tender amount of works where manufacturer's test certificate not available	Tendered amount of works where water not tested	Tender amount of works where non-theoretical statement of consumption was not available
1.	Construction of 01 block of 03 nos. single men barrack for 06 NCOs and 60 others (G+II) and 01 no. administrative block (G+I) for 21 Assam Rifles at Kakching	AR	NPCCCL	319.96	319.96	319.96
2.	Construction of magazine building for AR Bn. at Kakching, Manipur	AR	NPCCCL	159.53	159.53	159.53
3.	Construction of 01 block of 03 nos. SM bk (G+II) and 01 block of cook house cum dining hall for AR Bn. at Phundrei	AR	NPCCCL	379.14	379.14	379.14
4.	Construction of residential building boundary wall around Mantripukhri Garrison at Mantripukhri (Manipur)	AR	NPCCCL	429.41	429.41	429.41
5.	Construction of 12 nos. Type-II (G+II) in 2 block and 10 nos. Type-IV(G+1) in 5 blocks with allied services and development works for Assam Rifles at Mantripukhri (Manipur)	AR	NPCCCL	424.64	424.64	424.64
6.	Construction of one block of 03 nos. Single men barracks (G+II) with approach road for new location of Assam Rifles at Phunderi (Manipur)	AR	NPCCCL	357.64	357.64	357.64
7.	Construction of security wall including main gate, sentry posts, Security lights etc for residential accommodation for AR Bn. at Modi(Manipur)	AR	NPCCCL	381.53	381.53	381.53
8.	Construction of administrative block(G+1) including allied services and development works for Assam Rifles new KLP at Phundrei(Manipur)	AR	NPCCCL	393.87	393.87	393.87
9.	Construction of QG, Kote, Armoury and Armr shop including development works and internal road for Assam Rifles Bn. at Modi(Manipur)	AR	NPCCCL	207.44	207.44	207.44
10.	Construction of 24 nos. Type-II SF quarters G+II including development works and allied services for IGAR (S) at Manthripukhari Manipur	AR	NPCCCL	414.58	414.58	414.58
11.	Construction of Security wall including main gate security light, foot path with plan sump IRP & 100 KVA transformer with HT/LT & sub-station for residential complex of AR Bn. at Keithalmanbi (Manipur)	AR	NPCCCL	408.74	408.74	408.74

12.	Construction of 06 nos. Single JCOs living accommodation (G+I), 01 Block of 03 nos. single men barrack (G+II), 01 no. administrative block (G+I) and 01 No. Officers Mess for Sector HQ and 01 block of 03 nos. Single men barrack (G+I) for Assam Rifles Bn. at Keithalmanbi (Manipur)	AR	NPCCL	1110.38	1110.38	1110.38
13.	Construction of one block of 04 nos. single men barrack (G+III) for Assam Rifles Bn. at Jawalamukhi and one block of 04 nos. Single men barrack (G+III) for Assam Rifles Bn. at Maram (Manipur)	AR	NPCCL	524.15	524.15	524.15
14.	Construction of 01 nos. T-VI (G +,F) 04 nos. Type-V (G+1), 13 nos. Type-III, 18 nos. T-II (G+II) and 02 nos. Single /Officers Accommodation with allied services and development works for Assam Rifles at Keithalmanbi.	AR	NPCCL	860.8	860.8	860.8
15.	Construction of 72 nos. T-II accommodation with development works and ancillary service for AR sect HQ/ Bn. HQ at Keithalmanbi at Manipur	AR	NPCCL	1265.95	1265.95	1265.95
16.	Construction of 48 nos. Type-II(G+II) in 08 block and 07 nos. single JCOs accommodation with development works,water supply and external electrification for Assam Rifles at Jwalamukhi(Manipur)	AR	NPCCL	1015.45	1015.45	1015.45
17.	Construction of boundary wall with RCC Posts and 1.35 KM New Road for Assam Rifles Bn. at Khuga (Manipur)	AR	HPL	418.96	418.96	418.96
18.	Construction of 01 block of 04 nos. Single Men Barrack (G+III) and 01 No cook house cum dining hall for Assam Rifles for Assam Rifles Bn. at Khuga(Manipur)	AR	HPL	402.45	402.45	402.45
19.	Construction of 03 nos. single men barrack (G+II) with approach road for KLP location of Assam Rifles Bn. at Khuga (Manipur)	AR	HPL	181.24	181.24	181.24
20.	Construction of 20 bedded Hospital including development works for AR bn at Khuga (Manipur)	AR	HPL	308.21	308.21	308.21
21.	Construction of 160 nos. Type-II family quarters at Group Centre (GC), Sonipat.	CRPF	NBCC	2571	0	0
22.	Construction of 236 development works Various Type (Type/II-160, Type/III-38, Type-IV-24, Type/V-14)	CRPF	NBCC	4502	0	0
23.	Construction of GOs mess/ suites and SOs mess/ dormitory at GC Bahalgarh, Sonipat.	CRPF	NBCC	871	0	0
24.	Construction of Boundary wall, main gate with signage & automatic boom barrier and watch tower at GC CRPF Bahalgarh, Sonipat, Haryana	CRPF	NBCC	642	0	0
25.	Construction of 240 Type-II quarters and development works at GC Sonipat	CRPF	NBCC	3858	0	0



26.	Construction of mens club, canteen & badminton court, mt garage, works shop, parade ground, fort wall, 10 bedded hospital, dhobi ghat and school at GC Sonipat.	CRPF	NBCC	1589	0	0
27.	Carrying out development and bulk services (Civil & Electrical ) works at GC Sonipat, Haryana	CRPF	NBCC	2509	0	0
28.	Construction of compound wall on western side & raising height of about 2100 mtrs. length of existing boundary wall	CRPF	CPWD	117.09	0	0
29.	Repair & re-carpeting of worn out portions of Harnal & Main Road at GC CRPF, Pinjore	CRPF	CPWD	33.80	0	0
30.	Construction of 60 nos. family quarters (T/III-22, T/IV- 24,T/V-12)	CRPF	CPWD	1633	0	0
31.	Construction of 117 nos. family quarters	CRPF	CPWD	396	0	0
32.	Construction of 3 nos. 180 men Barracks	CRPF	CPWD	873.00	0	0
33.	Construction of 04 development works, Nallah, RCC Sump well Services, admn. block and quarter guard	CRPF	CPWD	918.47	0	0
34.	Underground water sump, lines and providing CGI sheet roofing	CRPF	CPWD	74.35	0	0
35.	Construction of boundary wall at CRPF campus, Nagrota	CRPF	CPWD	185.9	0	0
36.	Construction of TYPE-II/126 nos.(G+II) family quarters at Jalandhar	CRPF	CPWD	1157	0	0
37.	Construction of approach road, water supply & sewage disposal for 180 men barrack hallomajra	CRPF	CPWD	129.3	0	0
38.	Construction of compounding wallat Hira Nagar	CRPF	CPWD	63.98	0	0
39.	Construction of sewage treatment plant at Saboli, Haryana	ITBP	CPWD	81	0	0
40.	Construction of store depot at Sabili, Haryana	ITBP	CPWD	73	0	0
41.	Construction of A.T. School, Veterinary hospital at Bhanu, Panchkula	ITBP	CPWD	88	0	0
42.	Construction of SOs Mess at 28th Bn., Jatusana, Rewari	ITBP	CPWD	291	0	0
43.	Augmentation of substation in residential campus at Ramgarh (SH: Construction of two room for transformers)	ITBP	CPWD	99	0	0
44.	Construction of National dog training center (kennel, cook house, grooming shed, hospital & development work) at Bhanu	ITBP	CPWD	236	0	0
45.	Construction of road up to firing range at Bhanu	ITBP	CPWD	73	0	0
46.	Construction of GOs mess at Bn. HQ at Bhanu	ITBP	CPWD	69	0	0

47.	Providing air conditioners in training block (Millennium Buildings) Bn. Training Centre (BTC)	ITBP	CPWD	102	0	0
48.	Construction of road up to firing range at BTC	ITBP	CPWD	73.2	0	0
49.	Renovation of 64 T-III, quarters and development works at Ramgarh	ITBP	Deptt.	39.28	0	0
50.	Renovation of 02 nos. old 120 men jawan barrack at Ramgarh	ITBP	Depart-mental	33.25	0	0
51.	Construction of MT workshop at Leh	ITBP	CPWD	194	0	0
52.	Construction of GOs Mess 15thbn Udampur	ITBP	CPWD	425	0	0
53.	Construction of SOs Mess and dormitory	ITBP	CPWD	496	0	0
54.	Construction of three nos. admn. block one each for company	ITBP	CPWD	998	0	0
55.	Construction of Training shed revised	ITBP	CPWD	524	0	0
56.	Construction of 36 No T-II quarters at Bn. HQ	ITBP	CPWD	851	0	0
57.	Construction of 120 men barrack at 21st Bn.	ITBP	CPWD	187	0	0
58.	Construction of admn. block (double story) at TPT Bn. Chandigarh	ITBP	CPWD	187	0	0
59.	Construction of T-1 to IV quarters at Patiala	ITBP	CPWD	182	0	0
60.	Construction of 01 block of 03 single men barrack (G+II) and 01 block of 06 Type-II (G+II) for No 2 transit camp at Jorhat (Assam)	AR	NPCCCL	0	369.16	0
61.	Construction of 32 Type-II quarters for Assam Rifles Bn. at Jorhat (Assam)	AR	NPCCCL	0	355.45	0
62.	Construction of 02 Type-V (G+1) with allied services and development works for Assam Rifles at Haflong Assam	AR	NPCCCL	0	160.57	0
63.	Construction of 3 single men barracks with allied services and dev works at Diphu (Assam)	AR	NPCCCL	0	368.82	0
64.	Construction of security wall in 1.7 km length with 2 main entry gate and dev work at New AR KLP at Gujarat	AR	UPJN	0	412.71	0
65.	Construction of 1 Block of 4 single men barracks, 01 no. JCO Mess and 01 No 20 bedded hospital for AR Bn. at Haflog Assam	AR	NPCCCL	0	486.34	0
66.	Construction of 12 nos. Type-III quarters and 66 Type-II quarters at Jorhat, Assam	AR	NPCCCL	0	879.57	0
67.	Construction of 64 nos. Type-II (G+III) quarters for AR at Charduar, Assam	AR	EPIL	0	744.79	0
68.	Augmentation of water supply scheme and 01 lakh capacity, overhead tank with staging & allied services for residential complex at Jairampur (Arunachal Pradesh)	AR	UPJN	0	351.98	0

69.	Construction of 10 single JCOs accommodation in 02 block of G+1 including infrastructural development works for AR at Jairampur Arunachal Pradesh	AR	EPIL	0	106.01	0
70.	Construction of MT accommodation with tech stores for AR at Khonsa Arunachal Pradesh	AR	EPIL	0	173.05	0
71.	Construction of 08 single men barracks (G+III), 04 single officers accommodation, 12 JCOs accommodation, 01 adman block, 01 officers mess, 01 JCOs mess for AR at Khonsa Arunachal Pradesh	AR	EPIL	0	1376.14	0
72.	Construction of 48 Type-II (G+III) quarters for AR at khonsa, Arunachal Pradesh	AR	EPIL	0	754.33	0
73.	Construction of 2 nos. Type-V quarters, 4 nos. single JCO accommodation and 16 nos. Type-II quarters for AR at Udaipur	AR	NPCCCL	0	386.68	386.68
74.	Construction of 16 nos. Type-II quarters, including allied services & development works at Agartala	AR	NPCCCL	0	206.64	206.64
75.	Construction of 6 nos. single men barracks with allied services and development works for AR at Radha Nagar	AR	NPCCCL	0	316.53	316.53
76.	Construction of 2 nos. Type-V quarters, 2 Type-IV, 12 nos. Type-III, 90 nos. Type-II, 6 nos. single officers accommodation for AR, Radhanagar, Tripura	AR	NPCCCL	0	1038.42	1038.42
77.	Construction of 8 nos. single JCO accommodation, 6 nos. single men barrack, 1 no. admn block, AR Radha Nagar, Tripura	AR	NPCCCL	0	642.9	642.9
78.	Construction of 78 nos. Type-II (G+II) quarters, 6 nos. Type-III (G+II) with allied services and development work at Teliamura	AR	NPCCCL	0	769.54	769.54
79.	Construction of boundary wall for Assam Riffls at Teliamura	AR	NPCCCL	0	374.73	374.73
80.	Construction of 01 block of 04 nos. single men barrack (G+III) and bituminous road for AR Bn. at Srikona, Silchar, Assam	AR	NPCCCL	0	0	394.17
81.	Construction of 01 block of 03 single men barrack(G+II) and 01 block of 06 Type-II (G+II) for No 2 transit camp at Jorhat (Assam)	AR	NPCCCL	0	0	369.16
82.	Construction of 32 Type-II quarters (SF) for Assam Riffls Bn. at Jorhat (Assam)	AR	NPCCCL	0	0	355.45
83.	Construction of 02 Type-V (G+1) with allied services and development works for Assam Riffls at Haflong Assam	AR	NPCCCL	0	0	160.57
84.	Construction of 3 single men barrack with allied services and dev works for COE Diphu (Assam)	AR	NPCCCL	0	0	368.82

85.	Construction of security wall in 1.7 km length with 2 main entry gate and dev work at New AR KLP at Gujarat	AR	UPJN	0	0	412.71
86.	Constructions of 1 block of 4 single men barracks, 01 no. JCOs Mess and 01 no. 20 bedded hospital for AR Bn. at Haflong, Assam	AR	NPCCCL	0	0	486.34
87.	Construction of 12 nos. Type-III quarters and 66 Type -II quarters separated family accommodation at Jorhat Assam	AR	NPCCCL	0	0	879.57
88.	Construction of 64 nos. Type-II (G+III) quarters for AR at Charduar Assam	AR	EPIL	0	0	744.79
89.	Augmentation of water supply scheme and 1 lakh capacity, overhead tank with staging & allied services for residential complex at Jairampur (Arunachal Pradesh)	AR	UPJN	0	0	351.98
90.	Construction of 10 single JCO accommodation in 02 block of G+1 including infrastructural development works for AR at Jairampur Arunachalpur	AR	EPIL	0	0	106.01
91.	Construction of MT accommodation with technical stores for AR at Khonsa Arunachal Pradesh	AR	EPIL	0	0	173.05
92.	Construction of 08 single men barrack (G+III), 04 single officers accommodation, 12 JCOs accommodation, 01 admn. block, 01 officers mess, 01 JCOs Mess for AR at Khonsa, Arunachal Pradesh	AR	EPIL	0	0	1376.14
93.	Construction of 48 Type-II (G+III) quarters for AR at khonsa, AP	AR	EPIL	0	0	754.33
94.	Construction of 01 block of 03 single men barracks, black top bituminous road and main drain for AR at Laitkor, Shillong (Meghalaya)	AR	NPCCCL	0	0	237
95.	Construction of 04 single men barracks (G+II) and in 01 block with allied services and development works at Laitkor, Shillong	AR	NPCCCL	0	0	301
96.	Construction of 72 Type-II (G+II) separated family accommodation for AR at Laitkor, Shillong	AR	NPCCCL	0	0	1096
<b>Total</b>				<b>37389.69</b>	<b>20238.43</b>	<b>22266.6</b>

**Annex -7.1**  
**Separate Accounts not maintained**  
**(Refer para-7.1)**

(₹ in lakh)

S.No.	Name of the Force	Name of the State	Particulars of the work	Executing Agency	Amount of mobilization advance given
1.	CRPF	Delhi	Constriction of 240 Men barracks Greater Noida	NBCC	386
2.	CRPF	Delhi	Constriction of Type-II,288 family quarters Greater Noida	NBCC	605
3.	CISF	Delhi	Construction of 4- Men's Barrack GOs Mess Special Security Group (SSG) Greater Noida	NBCC	27.37
4.	CISF	Delhi	Construction of 108 Residential quarters SSG Greater Noida	NBCC	112.21
5.	CISF	Delhi	Construction non-residential building for Government Building Security (GBS) CISF Group, Mahipalpur	NBCC	2039.73
6.	BSF	MP	Construction of Administration/Communication block for Reserve Bn. BSF Campus at Indore (MP)	NBCC	55.4
7.	BSF	MP	Construction of GOs Mess with 07 suites for BSF Bn. HQ at Indore Campus (MP)	NBCC	43.91
8.	BSF	MP	Construction of Type-III(G+2) residences, 26 nos.for BSF Bn. HQ at Indore Campus(MP)	NBCC	96.57
9.	CRPF	MP	Combined building of Admn./Training Block/ Class Room / Sand Model Room-cum-lecture hall and 2 nos.270 men barracks at Counter Insurgency and Anti-Terrorist School (CIAT) Shivpuri	NBCC	853.77
10.	CRPF	MP	Construction of combined building of GOs mess & suites, SOs mess & dormitory block, combined building for quarter guard, store block, tradesmen shop, and combined building for men's club, canteen, grain godown, badminton court and gymnasium at Central Training Centre (CTC) Shivpuri, MP	NBCC	847.29
11.	BSF	Haryana	Construction of main entrance gateway & dormitory block /side entrance gateway & dormitory block & refurbishment of boundary wall for Reserve Bn. BSF campus at Bhondsi, Gurgaon (Haryana)	NBCC	106.08
12.	BSF	Haryana	Construction of 01 nos. 120 men barrack including Information & Recreation Centre for Reserve Bn. BSF campus Bhondsi	NBCC	106.19
13.	BSF	Haryana	Construction of 01 nos. 120 men barrack including Information & Recreation Centre for Reserve Bn. BSF campus Bhondsi	NBCC	106.19
14.	CRPF	Haryana	Construction of 160 nos.Type-II family quarters at Group Centre (GC) Sonipat	NBCC	522.5
15.	CRPF	Haryana	Construction of 236 nos. various type(Type/II-160, Type/III-38, Type-IV-24, Type/V-14)	NBCC	915.79
16.	CRPF	Haryana	Construction of GOs mess/ suites and SOs mess/ dormitory at GC Bahalgarh, Sonipat	NBCC	176.92

17.	CRPF	Haryana	Construction of boundary wall, main gate with signage & automatic boom barrier and watch tower at GC CRPF Bahalgarh, Sonipat, Haryana	NBCC	130.39
18.	CRPF	Haryana	Construction of 240 nos. Type-II quarters at Group Centre, Sonipat	NBCC	783.76
19.	CRPF	Haryana	Construction of Men's club, canteen & badminton court, MT garage, works shop, parade ground, fort wall, 10 bedded hospital, dhobi ghat, and School at GC Sonipat	NBCC	322.81
20.	CRPF	Haryana	Carrying out development and bulk services (Civil & Electrical ) works at GC Sonipat, Haryana	NBCC	526.21
<b>Total</b>					<b>8764.09</b>

**Annex -7.2**  
**Non-recovery of Liquidated Damages (LD)**  
**(Refer para.7.2)**

(₹ in lakh)

S. No	Force	State	Particulars of the work	Executing Agency	Tendered Value	delay (in month)	Leviable Liquidated Damage
1.	CISF	UP	Construction of boundary wall with coil fencing at Kalindipuram Allahabad	CPWD	37.00	7	3.70
2.	CISF	UP	Construction of main gate at Kalindipuram Allahabad	CPWD	12.00	5	0.82
3.	CRPF	UP	Construction of 60 women barrack for 104th Bn. CRPF, Rapid Action force (RAF) Aligarh	CPWD	88.45	14	8.85
4.	CRPF	UP	Site development and bulk Services at 104th Bn. RAF Aligarh	CPWD	486.00	12	48.60
5.	CRPF	UP	Construction of 15 nos. watch lower & guard rooms	CPWD	47.94	12	4.79
6.	CRPF	UP	Construction of boundary wall & 2 nos. watch towers with guard rooms & providing with concertina wire on top in front of CWS 6.5 acres land for security reasons.	CPWD	56.87	4	5.69
7.	CRPF	UP	Construction of 50 bedded hospital at Group Centre (GC), Allahabad.	CPWD	628.44	15	62.84
8.	CRPF	UP	Construction of 121 nos. BOAC at Allahabad.	CPWD	22.87	15	2.29
9.	CRPF	UP	Renovation of 40 nos. toilets at CRPF campus, Allahabad.	CPWD	40.52	12	4.05
10.	CRPF	UP	Construction of one no. 60 women barrack, 101 RAF Allahabad.	CPWD	86.64	8	8.66
11.	CRPF	UP	Construction of 250 nos. family quarters (T/II-240, IV-8, V-2) GC, Allahabad.	CPWD	1699.30	9	169.93
12.	CRPF	UP	Construction of MT Garage and Workshop	CPWD	241.96	7	24.20
13.	CRPF	UP	Construction of 278 nos. (T/12 & T/II-266 nos.) family quarters, Lucknow	CPWD	1082.30	30	108.23
14.	CRPF	UP	Renovation of street light and park light at CRPF campus, Allahabad	CPWD	21.00	4	1.48
15.	ITBP	UP	Construction of boundary wall, road, sentry post including front gate & front wall and dormitory block with attached toilet at Greater Noida	CPWD	329.22	24	32.92
16.	SSB	UP	Construction of permanent infrastructure BOP Khunwa Bn. HQ Maharajganj.	CPWD	289.08	12	28.91
17.	SSB	UP	Construction of permanent infrastructure BOP Chandithan Bn. HQ Maharajganj.	CPWD	348.13	12	34.81

18.	SSB	UP	Construction of permanent infrastructure BOP Jhingi Bn. HQ Maharajanj.	CPWD	316.17	11	31.62
19.	SSB	UP	Construction of permanent infrastructure BOP Dranoura Bn. HQ Siddharth Nagar.	CPWD	309.65	12	30.97
20.	SSB	UP	Construction of permanent infrastructure BOP Lohti Bn. HQ Siddharth Nagar.	CPWD	324.16	7	32.42
21.	SSB	UP	Construction of prefabs structures at Lakhimpur Kheri.	Departmental	57.02	2	1.72
22.	SSB	UP	Construction of permanent building at BOP Bankati under 39th Bn. Palia.	Departmental	49.84	17	4.98
23.	SSB	UP	Development & bulk services for Ftr. HQ, SSB at Gomtinagar, Lucknow	CPWD	180.95	4	10.78
24.	SSB	UK	Construction of residential quarters (T/IV-02, T/I-12 nos.) at Bn. HQ Almora	CPWD	123.00	10	12.30
25.	SSB	UK	Construction of barbed wire fencing at Bn. HQ Champawat.	Departmental	30.00	7	3.00
26.	CRPF	UK	Construction of administration building	NBCC	2018.00	10	201.80
27.	CRPF	UK	Construction of three nos. 240 men barracks	NBCC	1570.00	6	135.26
28.	ITBP	UK	Construction of eight nos. T-II (double storied) quarters at Gothi	CPWD	82.00	1	8.20
29.	ITBP	UK	Construction of GOs mess at Munsyari	CPWD	66.00	1	0.99
30.	ITBP	UK	Construction of quarter master store at 36th Bn. Lohaghat	CPWD	263.00	1	2.63
31.	ITBP	UK	Construction of 10 bedded hospital at Mirthi	CPWD	136.00	14	13.60
32.	ITBP	UK	Construction of residential cum office complex at Mana	CPWD	77.00	56	7.70
33.	ITBP	UK	Construction of administration block and training block at Auli	CPWD	295.00	15	29.50
34.	ITBP	UK	Development of storm water system & drains at 12 Bn. Matli	CPWD	96.00	20	9.60
35.	ITBP	UK	Construction of administration block for 1 <sup>st</sup> Bn	CPWD	199.00	26	19.90
36.	ITBP	UK	Construction of chain link fencing in remaining area of Bn. HQ of ITBP at Mahidanda	CPWD	154.00	13	15.40
37.	ITBP	UK	Water supply and drainage system Jalagam Parisar at Gaucher	CPWD	80.00	8	8.00
38.	ITBP	UK	Construction of officer mess at Auli	CPWD	106.00	13	10.60
39.	ITBP	UK	Construction of quarter guard, quarter master store and MI room at Auli	CPWD	266.00	11	26.60



40.	ITBP	UK	Construction of separated family accommodation at ITBP Seemadwar Dehradun,	CPWD	2336.57	38	233.66
41.	ITBP	UK	Augmentation of water supply line at Seemadwar Dehradun (Revised)	CPWD	77.00	1	0.77
42.	ITBP	UK	Construction of quarter guard in Astel Estate of ITBP Academy Massoorie Dehradun	CPWD	185.00	14	18.50
43.	CRPF	Bihar	Construction of administration block GC, Muzaffarpur, Bihar	CPWD	115.96	34	11.59
44.	CRPF	Bihar	Construction of 8 nos. barracks at RTC-V, Rajgir	CPWD	178.11	5	17.81
45.	CRPF	Bihar	Construction of administration block for IGP /DIGP Office	CPWD	170.45	26	17.04
46.	CRPF	Bihar	Construction of SOs mess & others mess (4 storied) for IG/DIGP Bihar Sector, CRPF at Digha	CPWD	572.25	17	57.22
47.	SSB	Bihar	Construction of Boundary wall at Bathnaha, Araria (Bihar).	CPWD	419.61	38	41.96
48.	SSB	Bihar	Construction of Boundary wall for Sector HQ SSB, Muzaffarpur.	CPWD	204.02	20	20.40
49.	SSB	Bihar	Construction of BOP Building at Coy HQ cum BOP at Sikta under Bn. HQ SSB, Narkatiaganj.	CPWD	332.69	28	33.27
50.	SSB	Bihar	Construction of BOP Building at Coy HQ cum BOP at Pantoka under Bn. HQ SSB, Piprakothi, District East Champaran.	CPWD	332.09	21	33.20
51.	SSB	Bihar	Construction of 128 Men Barrack at SSB Bn. Head Quarters, Bathnaha, District Araria (Bihar).	CPWD	370.27	20	37.03
52.	SSB	Bihar	Construction of Type-III-24 nos., T-IV-6 nos. & T-V-2 nos. for SSB at Narkatiaganj.	CPWD	445.30	29	44.53
53.	SSB	Bihar	Construction of 10 Bedded hospital at 12th Battalion HQ, Bagha, Valmikinagar, Bihar.	CPWD	408.97	23	40.89
54.	SSB	Bihar	Construction of 53 nos. Type-II Quarters at Sector Head Quarter for SSB, Muzaffarpur. ( Bihar )	CPWD	602.57	21	60.23
55.	SSB	Bihar	Development of site & Bulk services for SSB at Narkatiaganj. SH: - Civil Works.	CPWD	978.73	12	97.87
56.	SSB	Bihar	Construction of BOP building at Majorganj under 9 <sup>th</sup> Bn, Sitamarhi	CPWD	245.31	37	24.53
57.	SSB	Bihar	Construction of BOP at HQ Kamla in Madhubani under 9 <sup>th</sup> Bn, Jaynagar	CPWD	242.54	36	24.25
58.	ITBP	(J&K)	Renovation of ceiling of type-II/24 and type-II/36 nos. quarters Leh.	Departmental	24.18	5	2.42
<b>Total</b>					<b>20558.13</b>		<b>1985.51</b>

**Annex – 7.3**  
**Excess payment made to contractor**  
**(Refer para 7.3.1)**

(₹ in lakh)

Sl. Nos.	Name of work	Force	PWOs	Amount	Description
1.	Construction of 12 nos. Type-III quarters in G+III & 54 Type-II quarters in G+III for 43 AR in Lohra Assam.	Assam Rifles	EPIL	1.70	Escalation for steel was to be allowed on the minimum of index for the period under consideration or whole sale cost index of the month in which half of the stipulated contact period was over or last consignment of steel reinforcement was procured. These conditions were not adhered to.
2.	Construction of 12 nos. T-III quarters in G+III & 66 T-II quarters in G+II for AR in Jorhat Assam.	Assam Rifles	NPCCCL	3.37	
3.	Construction of 4 nos. of single men barracks (G+II), 01 no. JCOs Mess and 01 nos. 20 bedded hospital for AR, Haflong, Assam.	Assam Rifles	NPCCCL	1.07	
4.	Construction of one block of 4 nos. ingle men barrack (G+III) for AR Bn. at Jawalamukhi and one block of 4 nos. ingle men barrack (G+III) for AR Bn. Maram (Manipur).	Assam Rifles	NPCCCL	0.96	
5.	Construction of 72 nos. Type-II (G+III) SF accommodation for AR at Laitkor, Shillong	Assam Rifles	NPCCCL	3.14	
6.	Construction of 24 Type-II quarters including development work for AR at Khonsa, Arunachal Pradesh.	AR		16.61	In work of Construction of 24 Type-II quarters including development works for AR at Khonsa, Arunachal Pradesh, escalation on labour was allowed on wrong base rate instead of taking the labour cost index applicable on the last date of receipt of tender.
7.	Construction of non-residential accommodation for office of Group Commandant, CISF, Group HQ, Guwahati, Assam (Block-A & Block-B) including development site.	CISF	CPWD	13.57	Escalation under clause 10C is a compensatory amount paid to contractor against increase in cost of labour. However, escalations were allowed on the total value of works which included 15 per cent contractor's profit.
8.	Construction of 18 nos. Type-II residential quarters for 33rd Bn. at Rangia Assam (phase-II) SSB.	SSB	CPWD	1.35	
9.	Construction of 6 numbers Type-IV and 2 nos. Type-V residential quarters at 38 Bn. SSB, Tawang.	SSB	CPWD	2.99	
10.	Construction of 3 nos.180 men barracks (3 storied) for Group Centre CRPF at Khatkhathi, Assam.	CRPF	CPWD	3.63	
11.	Construction of 8 nos. single men barrack, 04 nos. ingle officers accommodation, 12 nos. single JCOs accommodation.	Assam Rifles	EPIL	3.34	Instead of taking index of 'Other Materials', it was taken for 'All Commodities' which resulted into overpayment.

12.	Construction of 1 nos. officers' mess, one nos. administrative block, one nos. JCOs mess including infrastructural development work	Assam Rifles	EPIL	2.01	
13.	Construction of 1 nos. Type-IV (G+F), 4 nos. Type-V (G+1), 13 nos. Type-III, 18 nos. Type-II (G+II) and 2 nos. single/ officers accommodation with allied services and development works for AR at Keithalmanbi, The work was executed under package i.e. 285,286,287.	Assam Rifles	NPCCL	5.78	
14.	Construction of 6 nos. single JCOs living accommodation G+1, 01 block of single men barrack (G+II), 01 no. administration block (G+1) and 01 no. officers mess for Sector HQ and 01 block of 3 nos. single men barrack (G+1) for AR for Kethalmanbi, Manipur.	Assam Rifles	NPCCL	2.28	
15.	Construction of 48 Type-II quarters of AR in Khonsa, Arunachal Pradesh.	Assam Rifles	EPIL	54.58	In one work <sup>1</sup> steel escalation was allowed taking the Wholesale Price Index (WPI) of Steel (long) instead of Steel (Rods) and in another work <sup>2</sup> estimate was prepared based on DPAR 2007 but escalation on steel was allowed on base year of 1993-94 instead of base year of 2004-05 resulted into excess payment.
16.	Construction of 1 nos. T-IV (G+F), 4 nos. Type-V (G+1), 13 nos. Type-III, 18 nos. T-II (G+II) and two nos. single officers' accommodation with allied services and development works for AR at Keithalmanbi, The work was executed under package i.e. 285,286,287.	Assam Rifles	NPCCL	6.80	Amount was to be recovered in excess on account of de-escalation of cement.
17.	Construction of six nos. single JCOs living accommodation G+1, 01 block of single men barrack (G+II), 01 no. administration block (G+1) and 01 no. officers mess for Sector HQ and 01 block of 3 nos. single men barrack (G+1) for AR for Kethalmanbi, Manipur.	Assam Rifles	NPCCL	7.27	

<sup>1</sup>Construction of 48 Type-II quarters of AR in Khonsa, Arunachal Pradesh executed by EPIL.

<sup>2</sup>Construction of 6 single JCOs living accommodation (G+1), 1 block of 3 single men barrack (G+2), one administrative block (G+1) for AR at Keithlmanbi, Manipur.

18.	Construction of residential accommodation at Zokhaswang, Mizoram.	Assam Rifles		335.00	No lump sum contract should be concluded except it is absolutely required. Audit found that EPIL awarded the work of construction of residential accommodation at Zokhaswang, Mizoram on a lump sum amount of ₹ 54.39 crore and executed agreement with the contractor with the provision for payment of escalation and paid escalation of ₹ 3.35 crore for the delay in execution of the work. But the AR while reimbursing the expenditure, failed to restrict such wrong payment.
19.	Construction of Training block.	CISF	CPWD	7.17	During the payment of labour price escalation under clause 10C, the value of work was determined as formula given in clause 10CC, $W=N-(K+L)$ , Where $N=0.85M$ and $M=C+F+I-J$ . But price escalation was given on the value $N=M$ in place $N=0.85M$ .
20.	Construction of Family Welfare Centre at CISF campus, Rajasthan.	CISF	CPWD	1.83	
21.	Construction of Semi-permanent structures for CISF RTC Behror Rajasthan.	CISF	CPWD	3.2	We noticed that CPWD in 5 cases paid ₹ 15.86 lakh in excess to contractors on account of price escalation under clause 10C.
22.	Construction of 05 nos. residential quarters (T-V 1, T-IV 4) for Regional Training Centre at RTC Deoli Rajasthan.	CISF	CPWD	0.24	
23.	Construction of boundary wall, main gate, guard room, watch towers and security lights at Group Centre-II Ajmer, Rajasthan.	CRPF	CPWD	3.42	
24.	Construction of 01 block of 04 nos. single men barrack (G+III) and bituminous road for Assam Rifles Bn. at Srikona Silchar.	AR	NPCCL	.97	Audit found that CPWD contract provision stipulating recovery of certain amount, in case a contractor utilizes Thermos Mechanically Treated (TMT) reinforcement bar produced by 'secondary producers' instead of 'primary producers', was not included in the 16 contracts concluded by PWOs with the contractors which resulted in non-recovery.
25.	Construction of 01 block of 03 nos. single men barrack (G+II) and 01 block of 06 nos. Type-II (G+II) for 2 nos. Transit Camp at Jorhat (Assam).	AR	NPCCL	1.28	
26.	Construction of 01 nos. single men barrack (G) in 01 block with allied services and development works at Jorhat (Assam).	AR	NPCCL	.21	
27.	Construction of 32 nos. Type-II separated family (SF) quarters for Assam Rifles Bn. at Jorhat (Assam).	AR	NPCCL	2.11	
28.	Const. of 04 nos. single men barrack (G+III), 01 nos. JCOs mess and 01 nos. 20 bedded hospital for AR at Haflong in Assam.	AR	NPCCL	3.06	
29.	Construction of 12 nos. Type-III quarters (G+II) and 66 nos. Type-II quarters (G+II) SF accommodation at Jorhat (Assam).	AR	NPCCL	5.96	

30.	Construction of 02 nos. Type-V (G+1) with allied services and development works for Assam Rifles at Haflong (Assam).	AR	NPCCL	.77	Audit found that CPWD contract provision stipulating recovery of certain amount, in case a contractor utilizes Thermos Mechanically Treated (TMT) reinforcement bar produced by 'secondary producers' instead of 'primary producers', was not included in the 16 contracts concluded by PWOs with the contractors which resulted in non-recover.
31.	Construction of 01 nos. Regimental school with allied services for AR at Lokra.	AR	NPCCL	.43	
32.	Construction of security wall in 1.7 km length with 02 nos. main entry gate and other related development work at new AR KLP at Guwahati.	AR	UPJN	1.23	
33.	Construction of 03 single men barracks with allied services and development works for Diphu (Assam).	AR	HPL	8.23	
34.	Augmentation of water supply scheme & overhead tank with staging & allied services for residential complex at Jairampur Arunachal Pradesh (AP).	AR	UPJN	8.23	
35.	Construction of 08 nos. single officer and 07 number single civilian accommodation including development works and allied services for AR at Srikona.	AR	NPCCL	1.97	
36.	Construction of 10 nos. single JCOs accommodation in 02 blocks of (G+I) including infrastructural development works for AR Bn. at Jairampur (Arunachal Pradesh).	AR	EPIL	2.26	
37.	Construction of 08 nos. single men barrack (G+III), 04 nos. single officers accommodation, 12 nos. single JCOs accommodation, 01 nos. administrative block (G+I), 01 no. officers mess, 01 no. JCOs mess for Assam Rifles Bn. at Khonsa (Arunachal Pradesh).	AR	EPIL	22.75	
38.	Construction of 48 nos. Type-II (G+III) quarters for Assam Rifles Bn. at Khonsa (Arunachal Pradesh).	AR	EPIL	17.77	
39.	Construction of 01 block of 04 nos. single men barrack(G+III) and Bituminous Road for Assam Rifles Bn. at Srikona, Silchar.	AR	NPCCL	.98	

40.	Construction of 48 nos. Type-II(G+II) in 08 block and 07 nos. single JCOs accommodation with development works, water supply and external electrification for Assam Rifles at Jwalamukhi (Manipur).	AR	NPCCL	3.6	NPCCL over-paid to contractors and AR incurred extra expenditure ₹ 9.17 lakh (including Departmental Charges and Work Contract Tax) for an item "Supplying and fabrication of Pressed Steel Tank" due to double addition of cost index.
41.	Construction of 72 nos. Type-II accommodation with development works and ancillary service for AR Sector HQ/Bn. HQ at Keithalmanbi at Manipur.	AR	NPCCL	5.57	
42.	Construction of 01 block of 03 nos. single men barracks, for 06 NCOs and 60 Others (Ors) (G+II) and 01 no. administrative block (G+I) for 21 AR at Kakching, Manipur.	AR	NPCCL	10.71	In one case <sup>3</sup> , last date of receipt of tender was 23 October 2008 but on the request of the contractor base price index was changed to February 2009. This led to undue advantage extended to the contractor.
43.	Construction of administration block in G+I for AR at Kakching, Manipur.	AR	NPCCL	7.09	Preliminary Estimates included installation of Fire Fighting Equipment. Audit, however, noted that Fire Fighting Equipment were not installed at all which led to excess payment
44.	Construction of 278 nos. (T/12 & T/II-266 nos.) family quarters.	CRPF	CPWD	9.23	Audit noticed that no list of materials was indicated in the Schedule 'F' while finalizing NIT of works. Besides, Clause 10 CA was not mentioned in the contract and appended to Schedule F. As the list of materials in Schedule F was not indicated, price variation was not admissible.
45.	Constructions of 60 women barrack for 104th Bn. CRPF, RAF Aligarh.	CRPF	CPWD	5.02	
46.	Construction of Separated Family Accommodation at ITBP Seemadwar Dehradun, SH: Construction of 200 nos. Type-I quarters & construction of Development work.	ITBP	CPWD	15.11	Though no percentage was mentioned in signed contract of two cases and appended to Schedule F, payment was made in disregard of the aforesaid provisions.
47.	Construction of administration block and training block at Auli.	ITBP	CPWD	7.45	
48.	Construction of separated family accommodation at ITBP Seemadwar, Dehradun, SH: Construction of 200 nos. Type-I quarters & construction of development work.	ITBP	CPWD	12.86	
49.	Construction of administration block and training block at Auli	ITBP	CPWD	5.97	
<b>Total</b>				<b>642.13</b>	

<sup>3</sup>(Construction of 01 block of 03 Nos. single men barrack, for 06 NCOs and 60 Others (G+II) and 01 No administrative block (G+I) for 21 AR at Kakching, Manipur)

**Annex -7.4**  
**Delay in submission of Performance Guarantee**  
**(Refer para 7.4)**

(₹ in lakh)

S. No	Name of the Work	Name of the Agency	Name of the Force	Delay in month	Amount of EMD
1.	Construction of 01 Block of 03 nos. single men barrack for 06 NCOs and 60 Ors (G+II) and 01 no. administration block (G+I) for 21 Assam Rifles at Kakching.	NPCCL	Assam Rifles	3	5.25
2.	Construction of magazine building for AR Bn. at Kakching	NPCCL	Assam Rifles	9	3.5
3.	Construction of 01 block of 03 nos. single men barrack(G+II) and 01 Block of Cook House cum Dining Hall for A.R Bn. at Phundrei.	NPCCL	Assam Rifles	7	7.5
4.	Construction of 12 nos. Type-II quarters. (G+II) in 02 blocks and 10 nos. Type-IV (G+I) in 5 blocks with allied services and development works for Assam Rifles.	NPCCL	Assam Rifles	3	2.6
5.	Construction of 24 nos. Type-II S.F quarters. (G+II) including allied services and development Works for IGAR(S).	NPCCL	Assam Rifles	5	5.5
6.	Construction of 04 nos. single officers accommodation. (G+I) in 1 block with allied services and development Works for AR Bn.	NPCCL	Assam Rifles	4	1.45
7.	Construction of 12 nos. single JCOs accommodation (G+II) in 2 blocks and 16 nos. Type-II quarters (G+III) in 2 blocks with allied services and development works for AR Bn.	NPCCL	Assam Rifles	6	7.75
8.	Construction of 01 nos. office building (G+I) in one block with allied services and development works for HQ, IGAR(S) AR.	NPCCL	Assam Rifles	6	4.45
9.	Construction of security wall including main Gate, sentry posts, security lights etc. for residential accommodation for AR Bn.	NPCCL	Assam Rifles	6	7.7
10.	Construction of quarter guard, kote, armory and arm shop including development works and internal road for AR Bn.	NPCCL	Assam Rifles	17	4.2
11.	Construction of 02 nos. Type-V quarters. (G) in 1 block including development works and allied services for 4 work shop AR.	NPCCL	Assam Rifles	4	7.9
12.	Construction of 1 no. storage accommodation(G) in 1 block including development works and allied services for 4 work shop AR.	NPCCL	Assam Rifles	4	1.5
13.	Construction of 06 nos. single JCOs accommodation (G+I), 01 block of 03 nos. single men barrack (G+II), 01 no. administration block (G+I) and 01 no Officers Mess for Sector HQ and 01 block of 03 nos. single men barrack (G+I) for Assam Rifles.	NPCCL	Assam Rifles	2	23.1
14.	Construction of 01 nos. Ty-IV (GF), 04 nos. Type-V, 30 nos. Type-III, 80 nos. Type-II and 02 nos. officer accommodation for AR Sector HQ	NPCCL	Assam Rifles	8	17.3
15.	Construction of 72 nos. Type-II accommodation with development works and ancillary service for A.R Sect HQ/ Bn. HQ	NPCCL	Assam Rifles	8	25.65

16.	Construction of 01 no. single men barrack (G) in 01 block with allied services and development Works for HQ Assam Rifles.	NPCCL	Assam Rifles	8	2.05
17.	Construction of 24 nos. single JCOs accommodation (G+III) in 3 block with allied services and development works for Assam Rifles.	NPCCL	Assam Rifles	4	5.85
18.	Construction of quarter guard, kote, armor shop (G) in 1 block with allied services and development works for Assam Rifles.	NPCCL	Assam Rifles	4	4
19.	Construction of 02 nos. Cook House cum Dining Hall (G) in 2 blocks with allied services and development works and construction of recreation room (G) in 1 block with allied services and development Works.	NPCCL	Assam Rifles	4	5.2
20.	Construction of Housing Project-24 nos. Type-II quarters (G+III) in 03 blocks with allied services and development works for Assam Rifles	NPCCL	Assam Rifles	5	7.9
21.	Construction of 2 nos. Type-V quarters 04 no. single JCOs accommodation and 16 nos. Type-II quarters for Assam Rifles Battalion at Udaipur	NPCCL	Assam Rifles	4	10.80
22.	Construction of 2 nos. Type-V, 2 nos. Type-IV, 12 nos. Type-III, 90 nos. Type-II 6 nos. single officers living accommodation along with internal and external services for 36 Assam Rifles at Radhanagar.	NPCCL	Assam Rifles	5	20.55
23.	Construction of 16 nos. Type-II (G+II) quarters including allied services and development works for Assam Rifles at Agartala	NPCCL	Assam Rifles	5	3.90
24.	Construction of 8 nos. single JCOs accommodations 6 nos. single men barracks, 1 no. administration block, 1 no. officers mess and 1 nos. JCO Club with allied services and development works for Assam Rifles at Radha Nagar (Tripura) & 1 no. officers mess with allied services and development works for Assam Rifles at Agartala.	NPCCL	Assam Rifles	8	12.80
25.	Construction of boundary wall for Assam Rifles at Teliamura.	NPCCL	AR	5	7.44
26.	Construction of 78 nos. Type-II (G+II) quarters, 6 nos. Type-III (G+II) with allied services and development works at Teliamura.	NPCCL	Assam Rifles	7	9.10
<b>Total</b>				<b>151</b>	<b>214.94</b>



**Annex – 7.5**  
**Non-deduction of Work Contract Tax**  
**(Refer para 7.5)**

(₹ in lakh)

S.No.	Name of the Force	Name of the State	Particulars of the work	Executing Agency	Short deduction of WCT	Non-deduction of WCT
1.	ITBP	Assam	Providing erection of 04 nos. plastic huts or store and jawans accommodation at Tezpur	Departmental	-	4.76
2.	SSB	Arunachal Pradesh	Construction of 02 nos. semi-permanent 20 men barrack at Company HQ Jang under 38th Bn.	Departmental	-	0.11
3.	BSF	Manipur	Construction of temporary structure (phase-II) for accommodation of communication set up and MT fleet of 140 Bn. Churachandpur, Manipur	Departmental	-	3.57
4.	AR	Mizoram	Construction of 08 nos. single JCOs accommodation (G+III) in one block along with development works and allied services for AR battalion at Lunglei (Mizoram).	EPIL	1.13	-
5.	AR	Mizoram	Supply and installation of 01 X 250 KVA Transformer for residential complex, street lights, security lights and allied services for Assam Rifles at Lunglei, Mizoram.	HPL	4.76	-
				<b>Total</b>	<b>5.86</b>	<b>8.44</b>
<b>Grand Total</b>						<b>14.33</b>

**Annex-7.6**  
**Details of cases where excess payment on WCT paid**  
**(Refer para 7.5)**

(₹ in lakh)

S.No	Name of the Work	Name of the Force	Name of Agency	WCT actually paid	WCT to be paid	Excess WCT paid
1.	Constriction of 01 block of 04 nos. single men barrack (G+III) and bituminous road for Assam Rifles Bn. at Srikona Silchar	Assam Rifles	NPCCCL	8.13	3.47	4.66
2.	Construction of 01 block of 04 nos. single men barracks, 01 no. JCOs mess and 01 no. 20 bedded hospital for Assam Rifles Battalion at Haflong (Assam)	Assam Rifles	NPCCCL	18.12	7.73	10.39
3.	Construction of 12 nos. Type-III quarters (G+II) and 66 nos. Type-II quarters (G+II) separated family accommodation at Jorhat (Assam)	Assam Rifles	NPCCCL	39.19	16.72	22.47
4.	Construction of 09 nos. single men barrack (G+II), 01 no. administration block (G+I) and 01 no. officers mess at Lokra for 43 Bn. AR.	Assam Rifles	EPIL	30.40	12.97	17.43
5.	Constriction of 12 nos. Type-III (G+II) and 54 nos. T-II (G+II) quarters for 43 Bn. AR at Lokra (Assam)	Assam Rifles	EPIL	45.10	19.24	25.86
6.	Constriction of 64 nos. Type-II (G+III) quarters for Assam Rifles Bn. at Charduar (Assam)	Assam Rifles	EPIL	2.08	0.89	1.19
		<b>Total</b>		<b>143.02</b>	<b>61.02</b>	<b>82.00</b>

**Annex – 7.7**  
**Non-deduction of Royalty**  
**(Refer para 7.5)**

(₹ in lakh)

S.No	Name of the Force	Name of the State	Particulars of the work	Executing Agency	Non-deduction of royalty
1.	BSF	Rajasthan	Construction of jawan barrack at Border Out Post (BOP) Vijeta, Binjour, Majnu & Kheruwala-64 Bn. BSF	Departmental	1.27
2.	BSF	Rajasthan	Construction of jawan barrack, cook house cum dining hall, administration block and kote store & magazine block at BOP Jagdev of 66 Bn. BSF	Departmental	0.38
3.	BSF	Rajasthan	Improvement of Type-I (44 nos..) quarters at Ftr. HQ BSF Rajasthan	Departmental	0.4
4.	BSF	Rajasthan	Re-carpeting drill square parade ground at Signal Training Centre (STC) BSF, Jodhpur	Departmental	0.28
5.	CISF	Rajasthan	Providing and laying chain link fencing around quarter guard	CPWD	0.31
6.	CISF	Rajasthan	Developing of rain water harvesting system at CISF campus RTC-I, Deoli, Rajasthan	CPWD	0.3
7.	CISF	Rajasthan	Construction of residual work at ceremonial parade ground	CPWD	0.46
8.	CISF	Rajasthan	Construction of boundary wall around cemetery ground	CPWD	0.2
9.	CRPF	Rajasthan	Maintenance and aesthetic improvement of Masuda House	CPWD	0.27
10.	CRPF	Rajasthan	Renovation of Type-II quarters nos. 01 to 48 at GC-1, Ajmer.	CPWD	1.14
11.	CRPF	Rajasthan	Development of Two nos. children park in residential area at CRPF	CPWD	0.62
12.	CRPF	Rajasthan	Development of existing pond	CPWD	0.38
13.	CRPF	Rajasthan	Renovation of toilets of barrack nos. 1 to 5	CPWD	0.71
14.	BSF	Rajasthan	Construction of quarter guard building at BSF campus, UDAIPUR	CPWD	1.78
15.	CISF	Rajasthan	Construction of Semi-permanent structures for CISF Regional Training Centre (RTC) Behror	CPWD	3.2
16.	CISF	Rajasthan	Construction of MT garage for Regional Training Centre (RTC) Behror	CPWD	0.84
17.	CISF	Rajasthan	Construction of 05 nos. residential quarters (T-V 1, T-IV 4) for RTC at Deoli	CPWD	0.24
18.	CISF	Rajasthan	Construction of sewage treatment plant for RTC Behror	CPWD	1.23
19.	CISF	Rajasthan	Construction of SOs Mess for CISF RTC Behror	CPWD	9.01
20.	CRPF	Rajasthan	Construction of boundary wall, main gate, guard room, watch towers and security lights at GC-II Ajmer, Rajasthan	CPWD	3.42
21.	CISF	Rajasthan	Construction of 02nos. of 180 men barracks	CPWD	6.34
22.	CISF	Rajasthan	Construction of 107 quarters (Type-II 84, Type-III 20, Type-IV 02 and Type-V 01) for RTC Behror	CPWD	7.99
23.	CISF	Rajasthan	Construction of non-residential buildings	CPWD	25.11
24.	CISF	Rajasthan	Construction of Family Welfare Centre	CPWD	1.6
<b>Total</b>					<b>67.48</b>

**Annex – 7.8**  
**Non-deduction of TDS, VAT and over payment due to voids deduction**  
**(Refer para 7.5 & 7.8)**

(₹ in lakh)

S.No	Name of the Force	Name of the State	Particulars of the work	Executing Agency	Non-deduction of TDS	Non-deduction of VAT	Amount of over payment due to voids deduction
1.	CRPF	Haryana	Construction of GOs mess/suites and SOs mess/dormitory at Group Centre (GC) Bahalgarh, Sonipat	NBCC	37		-
2.	CRPF	Telangana	Construction of Sewage Treatment Plant, laying of CI pipe line grid for horticulture purpose	CPWD	7.26		-
<b>Total</b>					<b>44.26</b>	<b>-</b>	<b>-</b>
3.	BSF	Rajasthan	Construction of 1 no.120 men barrack including development works at 84 Bn. BSF Campus-I located at Sum Road, Jaisalmer	CPWD	-	0.42	-
4.	CISF	Rajasthan	Construction of MT garage for RTC Behror	CPWD	-	0.14	-
5.	CISF	Rajasthan	Construction of Sewage treatment plant for RTC Behror	CPWD	-	0.22	-
<b>Total</b>						<b>0.78</b>	<b>-</b>
6.	AR	Manipur	Construction of magazine building with allied services and development work at Kakching, Manipur	NPCCCL	-	-	3.11
7.	AR	Manipur	Construction of security wall including main gate, sentry posts, security lights etc. for residential accommodation for AR Bn. at Modi (Manipur)	NPCCCL	-	-	0.21
8.	AR	Manipur	Construction of boundary wall with RCC Posts and 1.35 km new road for Assam Rifles Bn. at Khuga (Manipur)	HPL	-	-	2.05
<b>Total</b>							<b>5.37</b>

**Annex - 7.9**  
**Security Deposit short recovered**  
**(Refer para 7.6)**

(₹ in lakh)

S. No	Name of work	Force	State	Executing agency	Security deposit short recovered
1.	Construction of 126 nos. family quarters at Group Centre, Jalandhar, Punjab	CRPF	Punjab	CPWD	2.71
2.	Construction of approach road for 180 men barracks, Hallmajra, Chandigarh	CRPF	Punjab	CPWD	0.26
3.	Renovation/up-gradation of Type-I to Type -V quarters at Sarahan, HP	ITBP	HP	CPWD	0.78
4.	Construction of relaying of existing sewer line at Telecom Training Centre, SSB Down Kothi, Kasumpti, Shimla (HP)	SSB	HP	CPWD	0.4
5.	Construction of Renovation of existing bituminous internal road at Telecom Training Centre (TTC), SSB Kasumpti, Shimla.	SSB	HP	CPWD	0.3
6.	Construction of overhead RCC tank of 50000 liter capacity at SSB Kasumpti, Shimla.	SSB	HP	CPWD	0.18
7.	Construction of fort wall in front portion of Kangra stadium at SSB Sapri, HP	SSB	HP	CPWD	0.35
8.	Construction of main gate at Kalindipuram Allahabad	CISF	UP	CPWD	0.26
9.	Construction of 60 women barrack for 104th Bn. CRPF, Rapid Action Force (RAF), Aligarh	CRPF	UP	CPWD	0.63
10.	Site development and bulk Services at 104th Bn. CRPF, RAF Aligarh	CRPF	UP	CPWD	7.60
11.	Construction of 15 nos. watch tower & guard rooms	CRPF	UP	CPWD	0.47
12.	Construction of boundary wall & 2 nos. watch towers with guard rooms & providing with concertina wire on top in front of 6.5 acres land for security reasons.	CRPF	UP	CPWD	1.49
13.	Construction of 50 bedded hospital at Group Centre, Allahabad.	CRPF	UP	CPWD	16.55
14.	Construction of 121 nos. BOAC at Allahabad.	CRPF	UP	CPWD	0.11
15.	Renovation of 40 nos. toilets at CRPF campus, Allahabad.	CRPF	UP	CPWD	0.36
16.	Construction of one no. 60 women barrack, 101 RAF Bn. Allahabad.	CRPF	UP	CPWD	0.16
17.	Construction of office of DIGP, Group Centre, Lucknow	CRPF	UP	CPWD	0.39
18.	Renovation of street light and park light at CRPF campus, Allahabad	CRPF	UP	CPWD	0.57

19.	Construction of 10 bedded hospital at Palia	SSB	UP	CPWD	1.12
20.	Construction of prefabricated structures at Lakhimpur Kheri	SSB	UP	Deptt.	0.63
21.	Construction of permanent building at Border Out Post (BOP) Bankati under 39th Bn. Palia.	SSB	UP	Deptt.	0.64
22.	Construction of residential cum office complex at Mana	ITBP	UK	CPWD	0.88
23.	Construction of administration block and training block at Auli	ITBP	UK	CPWD	15.79
24.	Development of storm water system & drains at 12th Bn. Matli	ITBP	UK	CPWD	9.74
25.	Construction of administration block for 1 <sup>st</sup> Bn, ITBP in Uttra Khand	ITBP	UK	CPWD	11.46
26.	Construction of chain link fencing in remaining area of Bn. HQ of ITBP at Mahidanda, Uttarakhand	ITBP	UK	CPWD	2.73
27.	Construction of QG, QM Store and MI room at Auli, Uttra Khand	ITBP	UK	CPWD	7.39
28.	Water supply and drainage system Jalagam Parisar at Gaucher, Uttarakhand	ITBP	UK	CPWD	0.43
29.	Construction of Officer Mess at Auli, Uttra Khand	ITBP	UK	CPWD	10.00
30.	Construction of seprated family accommodation at ITBP Seemadwar, Dehradun.	ITBP	UK	CPWD	46.72
31.	Construction of quarter guard in Astel Estate of ITBP Academy Mussoorie Dehradun	ITBP	UK	CPWD	5.91
32.	Construction of semi-permanent structures for CISF RTC, Behror	CISF	Rajasthan	CPWD	8.84
33.	Construction of MT garage for RTC Behror	CISF	Rajasthan	CPWD	0.92
34.	Construction of sewage treatment plant for RTC Behror	CISF	Rajasthan	CPWD	1.47
35.	Construction of Boundary wall, main gate, guard room, watch towers and security lights at Group Centre-II Ajmer, Rajasthan	CRPF	Rajasthan	CPWD	0.75
36.	Construction of relaying of existing sewer line at Telecom Training Centre, SSB Down Kothi, Kasumpti, Shimla (HP)	SSB	HP	Departmental	0.4
37.	Renovation of existing bituminous internal road at Telecom Training Centre (TTC) SSB Kasumpti, Shimla.	SSB	HP	Departmental	0.3
38.	Construction of overhead RCC tank of 50000 liter capacity at SSB Kasumpti, Shimla.	SSB	HP	Departmental	0.18
<b>Total</b>					<b>159.87</b>

**Annex 7.10**  
**Diversion of fund**  
**(Refer para 7.7)**

(₹ in lakh)

S.No	Name of work	Force	State	Executing Agency	Sanctioned Amount	Amount diverted
1.	Construction of 3 nos. 180 men barrack at Humhama	CRPF	J&K	CPWD	1326.88	61.64
2.	Construction of 4 nos. Nallah and RCC sump well, Jammu	CRPF	J&K	CPWD	958.71	48.69
3.	Construction of National Training Centre for dogs, ITBP Bhanu, Haryana	ITBP	Haryana	CPWD	236	24.22
4.	Construction of 501 Type-II quarters at Group Centre, CRPF, Neemuch (MP)	CRPF	MP	CPWD	4568	35.1
5.	Providing modular work station in DG BSF HQ, CGO Complex, New Delhi	BSF	Delhi	DEPTT.	59.09	8.86
6.	Development work of land at IGI Airport, New Delhi	NSG	Delhi	CPWD	99.76	13.09
<b>Total</b>					<b>7248.44</b>	<b>191.6</b>

**Annex – 7.11**  
**Cases where soil testing not done during pre-construction stage**  
**(Refer para 7.8)**

(₹ in lakh)

S. No.	Name of work	Name of Force	Executing Agency	Amount
1.	Construction of Housing Project-24 nos. type-II quarters. (G+III) in 03 blocks with allied services and development work for AR Bn. at Pallel (Manipur)	AR	NPCCL	21.28
2.	Construction of 24 nos. Type-II separated family quarters (G+II) including development work and allied services for IGAR (S) at Manthripukhari Manipur.	AR	NPCCL	15.11
3.	Construction of 72 nos. Type-II accommodation with development work and ancillary service for AR Sector HQ/Bn. HQ at Keithalmanbi at Manipur	AR	NPPCL	25.02
<b>Total</b>				<b>61.41</b>



## Glossary

Sl. No.	Abbreviation	Full Form
<b>A</b>		
1.	AAI	Airport Authority of India
2.	AA & ES	Administrative Approval & Expenditure Sanction
3.	AR	Assam Rifles
4.	AE	Assistant Engineer
5.	AGM	Assistant General Manager
<b>B</b>		
6.	BHU	Banaras Hindu University
7.	BOP	Border Out Post
8.	BOQ	Bill of Quantities
9.	BOO	Board of Officers
10.	BG	Bank Guarantees
11.	BSF	Border Security Force
<b>C</b>		
12.	CVC	Central Vigilance Commission
13.	CZ	Central Zone
14.	CISF	Central Industrial Security Force
15.	CRPF	Central Reserve Police Force
16.	CoBRA	Commando Battalion for Resolute Action
17.	CPWD	Central Public Work Department
18.	CAPFs	Central Armed Police Forces
<b>D</b>		
19.	DC	District Collector
20.	DPAR	Delhi Plinth Area Rate
21.	DMTC	Disaster Management Training Centre
22.	DGACE	Director General of Audit Central Expenditure
23.	DE	Detailed Estimate
24.	DMRC	Delhi Metro Rail Corporation

<b>E</b>		
25.	EFC	Expenditure Finance Committee
26.	EE	Executive Engineer
27.	EPC	Engineering Procurement and Construction
28.	EOT	Extension of Time
29.	EPIL	Engineering Projects India Limited
<b>F</b>		
30.	Ftr HQ	Frontier Headquarters
<b>G</b>		
31.	Gatta	Piece of land identified by a particular number.
32.	GoTN	Government of Tamilnadu
33.	GBS	Government Building Security
34.	GC	Group Centre
35.	GoM	Government of Maharashtra
<b>H</b>		
36.	HPL	Hindustan Prefab Limited
37.	HT	High Tension
<b>I</b>		
38.	IIM	Indian Institute of Management
39.	ITBP	Indo-Tibetan Border Police
40.	IED	Improvised Explosive Device
<b>J</b>		
41.	JKPCC	Jammu and Kashmir Project Construction Corporation
<b>K</b>		
42.	KLP	Key Location Plan
43.	KV	Kendriya Vidyalaya
<b>L</b>		
44.	LOP	Lay out plan
45.	LD	Liquidated Damage
46.	LOI	letter of intent
<b>M</b>		
47.	MHA	Ministry of Home Affairs
48.	MIDC	Maharstra Industrial Deveolopement Cororation

49.	MSRDC	Maharashtra State Road development Corporation
50.	MoU	Memorandum of Understanding
51.	MIDC	Maharashtra Industrial Development Corporation
52.	MSEDCL	Maharashtra State Electrical Development Corporation Ltd.,
<b>N</b>		
53.	NIT	Notice Inviting Tender
54.	NSG	National Security Guard
55.	NMCD	Navi Mumbai Central Division
56.	NCD	Nagpur Central Division
57.	NCED	Nagpur Central Electrical Division
58.	NBCC	National Building Construction Corporation
59.	NPCCL	National Projects Construction Corporation Limited
<b>O</b>		
60.	OPWOs	Other Public Works Organizations
61.	OB	Office Buildings
<b>P</b>		
62.	PG	Performance Guarantee
63.	PMC	project management charges
64.	PE	Preliminary Estimates
65.	PDA	Principal Director of Audit
66.	PPP	Public Private Partnership
67.	PCD	Pune Central Division
68.	PCED	Pune Central Electrical Division
<b>Q</b>		
69.	QAW	Quality Assurance Wing
<b>R</b>		
70.	RB	Residential Building
71.	RAF	Rapid Action Force
72.	RH	Regional Hub
73.	RC	Regional Centre
<b>S</b>		
74.	SD	Security Deposits
75.	SSB	Sashastra Seema Bal
76.	STC	Subsidiary Training Centre

77.	SOP	Standard Operating Procedure
78.	SLAO	State Land Acquisition Officers
79.	SSC	Site Selection Committee
80.	SOP	Standard Operating Procedure
81.	SSG	Special Security Group
82.	SHQ	Sector Headquarters
83.	SE	Superintendent Engineer
	<b>T</b>	
84.	TS	Technical Sanction
85.	TMT bar	Thermo Mechanically Treated Bar
	<b>U</b>	
86.	UPJN	Uttar Pradesh Jal Nigam
	<b>W</b>	
87.	WCT	Works Contract Tax
88.	WWC	Workers Welfare Cess